

4275.501 Shown.

**MODEL NUMBER:**

- 4275.500 Kitchen Faucet**  
Metal Lever Handles. Less Handspray.
- 4275.501 Kitchen Faucet**  
Metal Lever Handles. Separate Handspray.

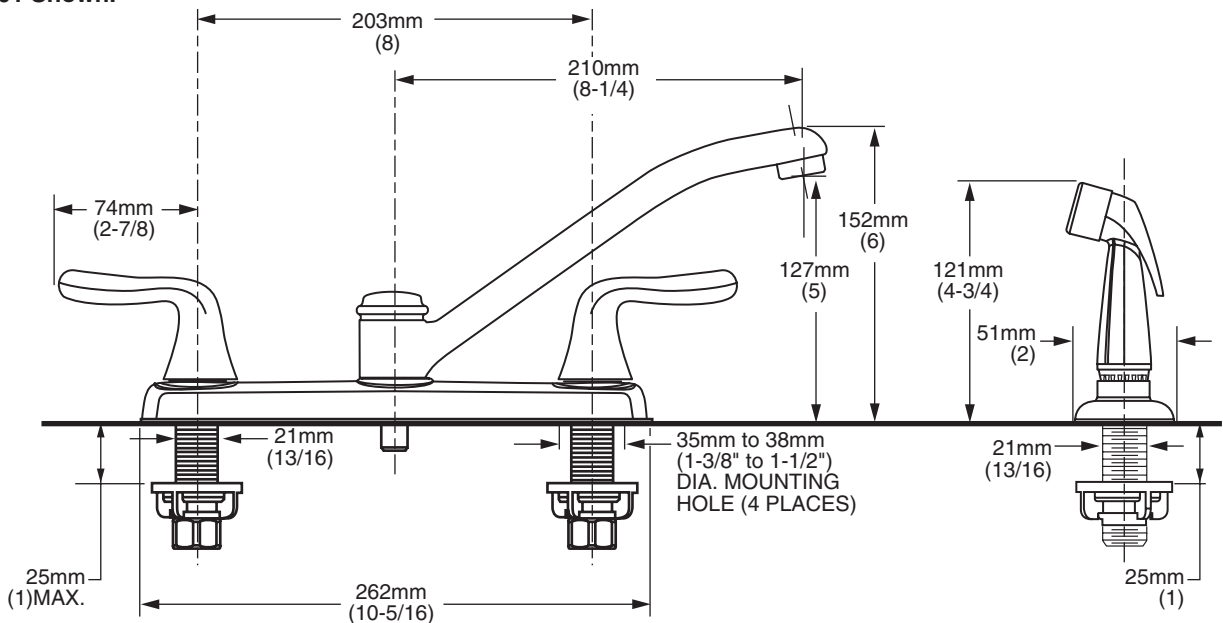

**GENERAL DESCRIPTION:**

Durable brass construction. 1/4 turn washerless ceramic disc valve cartridges. Durable cast brass waterway with 1/2" male inlet shanks. 8-1/4 (210mm) long cast brass swivel spout. Metal lever handles. Metal escutcheon plate (escutcheon size 10-5/16"L x 2-3/8"W). 2.2gpm/8.3L/min. maximum flow rate.

**PRODUCT FEATURES:**

**Ceramic Disc Valve Cartridges:** Assures a lifetime of drip-free performance.

**Cast Brass Waterways with "City Shanks":** Strong and durable. Integral tabs on casting provide a wobble-free installation.

**Low Lead:** Meets NSF Standard 61/Section 9 & Prop 65 lead requirements.

**Simple Installation:** Fast and easy one person installation. Faucet drops in from top. Quick spin nuts secure faucet in place.

**SUGGESTED SPECIFICATION:**

Two handle kitchen faucet shall feature brass construction with brass inlet shanks and coupling nuts. Brass swivel spout. Shall also feature 1/4 turn washerless ceramic disc valve cartridges that are reversible for use on either "hot" or "cold" side. Fitting shall be American Standard Model # 4275.5\_\_\_\_.

**CODES AND STANDARDS**

These products meet or exceed the following codes and standards:

- ASME A112.18.1**
- CSA B 125**
- NSF 61/Section 9**
- ANSI A117.1**

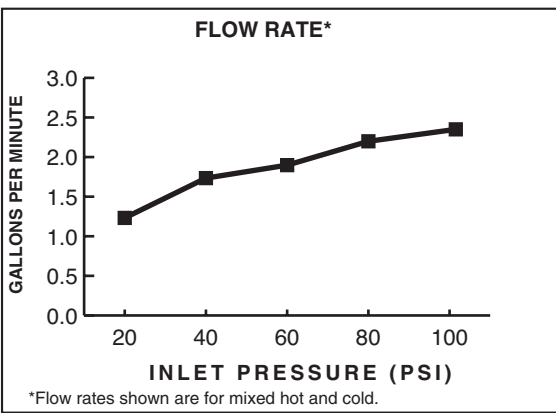

Product Number	Description	Finish Options	
		Polished Chrome	PVD Polished Brass
		002	099
4275.500	Kitchen faucet. Metal Lever handles. Less Handspray.		
4275.501	Kitchen faucet. Metal Lever handles. Separate Handspray.		



Meets the American Disabilities Act Guidelines and **ANSI A117.1** Requirements for the physically challenged.