



MC Series Gas-Fired Circulating Heater



INSTALLATION

START-UP

MAINTENANCE

PARTS

Models
MC50 / MC80
MC99 / MC120



CAUTION

When installing models manufactured after July 7, 2008, you will notice additional selections on the control installer menu that will not apply to this unit. **DO NOT CHANGE THESE FACTORY SETTINGS.** Refer to the Control Program Reference Chart within this manual for selections that apply to this model.

⚠ DANGER

This manual must be used by a qualified installer/service technician. Read all instructions in this manual before installing. Perform steps in the given order. Failure to comply could result in substantial property damage, severe personal injury, or death.

NOTICE: HTP reserves the right to make product changes or updates without notice and will not be held liable for typographical errors in literature.

NOTE TO CONSUMER: PLEASE KEEP ALL INSTRUCTIONS FOR FUTURE REFERENCE.

⚠ WARNING

IF THE INFORMATION IN THIS MANUAL IS NOT FOLLOWED EXACTLY, A FIRE OR EXPLOSION MAY RESULT, CAUSING PROPERTY DAMAGE, PERSONAL INJURY, OR LOSS OF LIFE. DO NOT STORE GASOLINE OR OTHER FLAMMABLE VAPORS AND LIQUIDS IN THE VICINITY OF THIS OR ANY OTHER HEATER.

WHAT TO DO IF YOU SMELL GAS

- Do not try to light any appliance.
- Do not touch any electrical switch.
- Do not use any phone in your building.
- Immediately call your gas supplier from a neighbor's phone. Follow the gas supplier's instructions.
- If you cannot reach your gas supplier, call the fire department. Installation and service must be provided by a qualified installer, service agency, or the gas supplier.

FOR YOUR SAFETY READ BEFORE OPERATING

WARNING: If you do not follow these instructions exactly, a fire or explosion may result, causing property damage, personal injury or loss of life.

- | | |
|--------------------------------------------------------------------------------------------------------------------------------------------------------------------------------------------------------------------------------------------------------------------------------------------------------------------------------------------------------------------------|------------------------------------------------------------------------------------------------------------------------------------------------------------------------------------------------------------------------------------------------------------------------------------------------------------------------------------------------------------------------|
| <p>A. This appliance does not have a pilot. It is equipped with an ignition device which automatically lights the burner. Do <u>not</u> try to light the burner by hand.</p> <p>B. BEFORE OPERATING smell all around the appliance area for gas. Be sure to smell next to the floor because some gas is heavier than air and will settle on the floor.</p> | <ul style="list-style-type: none"> • If you cannot reach your gas supplier, call the fire department. <p>C. Use only your hand to turn the gas control knob. Never use tools. If the handle will not turn by hand, don't try to repair it, call a qualified service technician. Force or attempted repair may result in a fire or explosion.</p> |
|--------------------------------------------------------------------------------------------------------------------------------------------------------------------------------------------------------------------------------------------------------------------------------------------------------------------------------------------------------------------------|------------------------------------------------------------------------------------------------------------------------------------------------------------------------------------------------------------------------------------------------------------------------------------------------------------------------------------------------------------------------|

WHAT TO DO IF YOU SMELL GAS

- Do not try to light any appliance
- Do not touch any electric switch; do not use any phone in your building
- Immediately call your gas supplier from a neighbor's phone. Follow the gas suppliers' instructions.

- D.** Do not use this appliance if any part has been under water. Immediately call a qualified service technician to inspect the appliance and to replace any part of the control system and any gas control which has been under water.

OPERATING INSTRUCTIONS

- | | |
|---------------------------------------------------------------------------------------------------------------------------------------------------------------------------------------------------------------------------------------------------------------------------------------------------------------------------------------------------------|--------------------------------------------------------------------------------------------------------------------------------------------------------------------------------------------------------------------------------------------------------------------------------------------------------------------------------------------------------------------------------------------------------------------------------------------------------------------------------------------------------------------------------------------------------------------------------------------------------------------------------------------------------------------------------------------------------------------------------------------------------|
| <ol style="list-style-type: none"> 1. STOP! Read the safety information above. 2. Set the thermostat to lowest setting. 3. Turn off all electric power to the appliance. 4. This appliance is equipped with an ignition device which automatically lights the burner. Do not try to light the burner by hand. | <ol style="list-style-type: none"> 5. Remove front cover. 6. Turn gas shutoff valve clockwise to "off". Handle will be vertical, do not force. 7. Wait five (5) minutes to clear out any gas. If you then smell gas, STOP! Follow "B" in the safety information above on this label. If you don't smell gas, go to next step. 8. Turn gas shutoff valve counterclockwise to "on". Handle will be horizontal. 9. Install Front Cover. 10. Turn on all electric power to appliance. 11. Set thermostat to desired setting. 12. If the appliance will not operate, follow the instructions "To Turn Off Gas To Appliance" and call your service technician or gas supplier. |
|---------------------------------------------------------------------------------------------------------------------------------------------------------------------------------------------------------------------------------------------------------------------------------------------------------------------------------------------------------|--------------------------------------------------------------------------------------------------------------------------------------------------------------------------------------------------------------------------------------------------------------------------------------------------------------------------------------------------------------------------------------------------------------------------------------------------------------------------------------------------------------------------------------------------------------------------------------------------------------------------------------------------------------------------------------------------------------------------------------------------------|

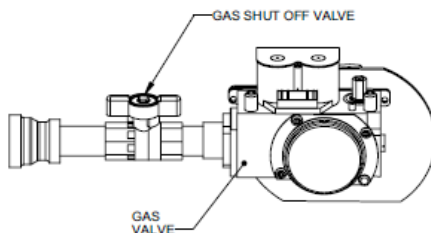

TO TURN OFF GAS TO APPLIANCE

- | | |
|--------------------------------------------------------------------------------------------------------------------------------------------------------------------------------------------------------------------|-------------------------------------------------------------------------------------------------------------------------------------------------------------------------|
| <ol style="list-style-type: none"> 1. Set the thermostat to lowest setting. 2. Turn off all electric power to the appliance if service is to be performed. 3. Remove Front Cover. | <ol style="list-style-type: none"> 4. Turn gas shutoff valve clockwise to "off". Handle will be vertical. Do not force. 5. Install Front Cover. |
|--------------------------------------------------------------------------------------------------------------------------------------------------------------------------------------------------------------------|-------------------------------------------------------------------------------------------------------------------------------------------------------------------------|

SPECIAL ATTENTION BOXES

The following defined terms are used throughout this manual to bring attention to the presence of hazards of various risk levels, or to important product information.

DANGER

DANGER indicates an imminently hazardous situation which, if not avoided, will result in death or serious injury.

WARNING

WARNING indicates a potentially hazardous situation which, if not avoided, could result in death or serious injury.

CAUTION

CAUTION indicates a potentially hazardous situation which, if not avoided, may result in minor or moderate injury.

CAUTION

CAUTION used without the safety alert symbol indicates a potentially hazardous situation which, if not avoided, may result in property damage.

FOREWORD

This manual is intended to be used in conjunction with other literature provided with the MC Series Gas-Fired Heater. This includes all related control information. It is important that this manual, all other documents included with this system, and additional publications including the National Fuel Gas Code, ANSI Z223.1-2002, be reviewed in their entirety before beginning any work.

Installation should be made in accordance with the regulations of the Authority Having Jurisdiction, local code authorities, and utility companies which pertain to this type of water heating equipment.

Authority Having Jurisdiction (AHJ) – The Authority Having Jurisdiction may be a federal, state, local government, or individual such as a fire chief, fire marshal, chief of a fire prevention bureau, labor department or health department, building official or electrical inspector, or *others having statutory authority*. In some circumstances, the property owner or his/her agent assumes the role, and at government installations, the commanding officer or departmental official may be the AHJ.

NOTE: HTP, Inc. reserves the right to modify product technical specifications and components without prior notice.

FOR THE INSTALLER

DANGER

This manual must only be used by a qualified heating installer/service technician. Read all instructions in this manual before installing. Perform steps in the order given. Failure to comply could result in severe personal injury, death or substantial property damage.

This heater must be installed by qualified and licensed personnel. The installer should be guided by the instructions furnished with the heater, and with local codes and utility company requirements. In the absence of local codes, preference should be given to the National Fuel Gas Code, ANSI Z223.1-2002.

INSTALLATIONS MUST COMPLY WITH:

Local, state, provincial, and national codes, laws, regulations and ordinances.

The latest version of the National Fuel Gas Code, ANSI Z223.1, from American Gas Association Laboratories, 8501 East Pleasant Valley Road, Cleveland, OH 44131.

In Canada – CGA No. B149 (latest version), from Canadian Gas Association Laboratories, 55 Scarsdale Road, Don Mills, Ontario, Canada M3B 2R3. Also, Canadian Electrical Code C 22.1, from Canadian Standards Association, 5060 Spectrum Way, Suite 100, Mississauga, Ontario, Canada L4W 5N6.

Code for the installation of Heat Producing Appliances (latest version), from American Insurance Association, 85 John Street, New York, NY 11038.

The latest version of the National Electrical Code, NFPA No. 70.

NOTE: The gas manifold and controls met safe lighting and other performance criteria when undergoing tests specified in ANSI Z21.10.3 – latest edition.

 WARNING
The hydronic supply and return connections of these products are for installation in closed loop systems ONLY! Use of this product in any manner other than described in this manual may result in premature product failure, substantial property damage, severe personal injury, or death. Damage or failure of this product (or the system in which it is installed) due to unauthorized use IS NOT COVERED BY WARRANTY.

TABLE OF CONTENTS

PART 1 – GENERAL SAFETY INFORMATION.....6

- A. PRECAUTIONS6
- B. IMPROPER COMBUSTION.....7
- C. GAS7
- D. WHEN SERVICING THE HEATER.....7
- E. HEATER SYSTEM.....7
- F. WATER CHEMISTRY*8
- G. WINTERIZING8

PART 2 – BEFORE YOU START 8

- A. WHAT’S IN THE BOX8
- B. HOW THE HEATER OPERATES8
- C. OPTIONAL EQUIPMENT 10

PART 3 – PREPARE HEATER LOCATION 10

- A. BEFORE LOCATING THE HEATER 10
- B. LEVELING 12
- C. CLEARANCES FOR SERVICE ACCESS..... 12
- D. RESIDENTIAL GARAGE, CLOSET, AND ALCOVE INSTALLATIONS 12
- E. EXHAUST VENT AND INTAKE PIPE 13
- F. PREVENT COMBUSTION AIR CONTAMINATION 13
- G. REMOVING AN EXISTING HEATER FROM AN EXISTING COMMON VENT SYSTEM 14

PART 4 – PREPARE HEATER..... 14

- A. REMOVE HEATER FROM BOX 14
- B. WALL MOUNTING CONSIDERATIONS..... 14
- C. WALL MOUNTING INSTRUCTIONS..... 15
- D. INSTALLATION STEPS..... 15

PART 5 – HEATER PIPING..... 15

- A. GENERAL PIPING INFORMATION..... 16
- B. RELIEF VALVE 16
- C. SEPARATE LOW WATER CUTOFF 17
- D. BACKFLOW PREVENTER..... 17

E. SYSTEM WATER PIPING METHODS 17

F. CIRCULATORS..... 18

G. HYDRONIC PIPING WITH CIRCULATORS, ZONE VALVES, AND MULTIPLE HEATERS 18

H. CIRCULATOR SIZING..... 19

I. ZONING WITH ZONE VALVES..... 19

J. ZONING WITH CIRCULATORS 20

K. MULTIPLE HEATERS..... 20

L. FILL AND PURGE HEATING SYSTEM 20

M. PIPING DETAILS 21

PART 6 – PIPING WITH OPTIONAL VISION 1 SYSTEM 28

A. VISION 1 SYSTEM PIPING 28

B. ZONING WITH ZONE VALVES USING VISION 1 28

C. ZONING WITH CIRCULATORS USING VISION 1 28

D. PIPING DETAILS WITH THE VISION 1 SYSTEM..... 29

PART 7 – VENTING, COMBUSTION AIR, AND CONDENSATE REMOVAL..... 39

A. GENERAL..... 39

B. APPROVED MATERIALS FOR EXHAUST VENT AND INTAKE PIPE 40

C. REQUIREMENTS FOR INSTALLATION IN CANADA..... 40

D. EXHAUST VENT AND INTAKE PIPE LOCATION..... 41

E. ROTATING THE FLUE ADAPTER 44

F. EXHAUST VENT AND INTAKE PIPE SIZING 45

G. LONGER VENT RUNS..... 45

H. EXHAUST VENT AND INTAKE PIPE INSTALLATION 46

I. VENTING DRAWINGS..... 46

PART 8 – GAS PIPING..... 48

A. GAS CONNECTION 48

B. GAS PIPING 50

C. CHECK INLET GAS PRESSURE 50

D. GAS VALVE..... 51

PART 9 – FIELD WIRING 52

A. INSTALLATION MUST COMPLY WITH: 52

B. FIELD WIRING..... 52

C. LINE VOLTAGE WIRING..... 52

D. THERMOSTAT 52

PART 10 – FIELD WIRING – VISION 1 OPTION 55

PART 11 – START-UP PREPARATION..... 57

A. CHECK/CONTROL WATER CHEMISTRY 57

B. FREEZE PROTECTION (WHEN USED) 58

C. FILL AND TEST WATER SYSTEM 58

D. AIR PURGING PROCEDURE FOR HEAT EXCHANGER..... 58

E. PURGE AIR FROM WATER SYSTEM 59

F. CHECK FOR GAS LEAKS 60

G. CHECK THERMOSTAT CIRCUIT(S) 60

H. CONDENSATE REMOVAL 60

I. FINAL CHECKS BEFORE STARTING HEATER 60

PART 12 – START-UP PROCEDURE..... 61

 A. OPERATING INSTRUCTIONS 61

 B. ADJUSTING THE SET POINT 61

 C. STATUS MENU 62

 D. TEST MODE 62

PART 13 – START-UP PROCEDURES WITH VISION 1 OPTION 62

 A. PROGRAMMING THE VISION I OPTION 63

 B. VISION 1 PROGRAM ACCESS..... 63

 C. VISION 1 PROGRAM NAVIGATION 63

PART 14 – TROUBLESHOOTING 65

 A. ERROR CODE..... 65

 B. HEATER ERROR..... 65

 C. HEATER FAULT 65

PART 15 – MAINTENANCE 67

 A. MAINTENANCE PROCEDURES..... 67

 B. MAINTENANCE SCHEDULE FOR THE SERVICE TECHNICIAN 68

 C. COMBUSTION CHAMBER COIL CLEANING INSTRUCTIONS 68

 D. MAINTENANCE SCHEDULE FOR THE OWNER 69

HEATER START-UP REPORT..... 74

MAINTENANCE REPORT 74

 MAINTENANCE NOTES 78

 HTP CUSTOMER INSTALLATION RECORD FORM 79

PART 1 – GENERAL SAFETY INFORMATION

A. PRECAUTIONS

This heater is for indoor installations only. Clearance to combustible materials: 0” top, bottom, sides and back. Front must have room for service, 24” recommended. (A combustible door or removable panel is acceptable front clearance.) This heater has been approved for closet installation. This heater is designed to be wall mounted. Do not install on the floor. Category IV vent systems only.

 WARNING
INSTALLER – Read all instructions in this manual before installing. Perform steps in the order given.
USER – This manual is for use only by a qualified heating installer/service technician. Refer to user’s information manual for your reference. Have this heater serviced/inspected by a qualified service technician annually.
FAILURE TO ADHERE TO THE GUIDELINES ON THIS PAGE AND HAVE THIS HEATER SERVICED/INSPECTED ANNUALLY CAN RESULT IN SUBSTANTIAL PROPERTY DAMAGE, SEVERE PERSONAL INJURY, OR DEATH.

NOTE: When inquiring about service or troubleshooting, reference the model and serial numbers from the heater rating label.

⚠ WARNING

DO NOT USE THIS HEATER IF ANY PART HAS BEEN SUBMERGED IN WATER. Immediately call a qualified service technician. The heater **MUST BE** replaced if it has been submerged. Attempting to operate a heater that has been submerged could create numerous harmful conditions, such as a potential gas leakage causing a fire and/or explosion, or the release of mold, bacteria, or other harmful particulates into the air. Operating a previously submerged heater could result in property damage, severe personal injury, or death.

NOTE: Heater damage due to flood or submersion is considered an Act of God, and IS NOT covered under product warranty.

⚠ WARNING

Be sure to disconnect electrical power before opening heater cabinet or performing service. Failure to do so could result in an electrical shock that could result in property damage, serious personal injury, or death.

NOTE: If the heater is exposed to the following, do not operate until all corrective steps have been made by a qualified serviceman:

1. FIRE
2. DAMAGE
3. WATER

Any claims for damage or shortage in shipment must be filed immediately against the transportation company by the consignee.

CAUTION

Due to the low water content of the heater, improper sizing of the heater with regard to heating system load will result in excessive cycling and accelerated component failure. HTP **DOES NOT** warrant failures caused by improperly sized heater applications. **DO NOT** oversize the heater to the system. Modular heater installations greatly reduce the likelihood of heater oversizing.

B. IMPROPER COMBUSTION

CAUTION

Do not obstruct combustion and ventilating air flow. Adequate air must be provided for safe operation. Failure to keep the exhaust vent and intake pipe clear of ice, snow, or other debris could result in property damage, serious personal injury, or death.

C. GAS

Should overheating or gas supply fail to shut off, do not turn off or disconnect electrical supply to circulator. Instead, shut off the gas supply at a location external to the heater.

D. WHEN SERVICING THE HEATER

- To avoid electric shock, disconnect electrical supply before performing maintenance.
- To avoid severe burns, allow heater to cool.

E. HEATER SYSTEM

- Do not use petroleum-based cleaning or sealing compounds in a heater system. Gaskets and seals in the system may be damaged. This can result in substantial property damage.
- Do not use "homemade cures" or "patent medicines". Substantial property damage, damage to heater, and/or serious personal injury may result.
- Continual fresh make-up water will reduce heater life. Mineral buildup reduces heat transfer, overheats the stainless steel heat exchanger, and causes failure. Addition of oxygen by make-up water can cause internal corrosion in system components. Leaks in the heater or piping must be repaired at once.
- If you have an old system with cast iron radiators, thoroughly flush the system (without heater connected) to remove sediment. The high-efficiency heat exchanger can be damaged by build-up or corrosion due to sediment.
- When the heater is used to supply potable water, do not connect it to any heating system or component(s) previously used with a non-potable water-heating heater.

NOTE: Damages resulting from incorrect installation or from use of products not approved by HTP, Inc. ARE NOT covered by warranty.

⚠ WARNING

Breathing Hazard - Carbon Monoxide Gas



- Do not operate heater if flood damaged.
- Install vent system in accordance with local codes and manufacturers installation instructions.
- Do not obstruct heater air intake or exhaust. Support all vent piping per manufacturers installation instructions.
- Do not place chemical vapor emitting products near unit.
- According to NFPA 720, carbon monoxide detectors should be installed outside each sleeping area.
- Never operate the heater unless it is vented to the outdoors.
- Analyze the entire vent system to make sure that condensate will not become trapped in a section of vent pipe and therefore reduce the open cross sectional area of the vent.

Breathing carbon monoxide can cause brain damage or death.
Always read and understand instruction manual.

LP-304 4/28/09

F. WATER CHEMISTRY*

- Sodium less than 20mGL.
- Water pH between 6.0 and 8.0
 - Maintain water pH between 6.0 and 8.0. Check with litmus paper or have it chemically analyzed by water treatment company.
 - If the pH differs from above, consult local water treatment company for treatment needed.
- Hardness less than 7 grains
 - Consult local water treatment companies for unusually hard water areas (above 7 grains hardness).
- Chlorine concentration less than 100 ppm
 - Using chlorinated fresh water should be acceptable as levels are typically less than 5 ppm.
 - Do not connect the heater to directly heat swimming pool or spa water.
 - Do not fill heater or operate with water containing chlorine in excess of 100 ppm.
- ***NOTE:** It is recommended to clean heat exchanger at least once a year to prevent lime scale buildup. To clean the heat exchanger, follow the maintenance procedure in Part 15, Section B of this manual.

Hardness: 7 grains

Chloride levels: 100 ppm

pH levels: 6-8

TDS: 2000 ppm

Sodium: 20 mGL

G. WINTERIZING

CAUTION

NEVER use any toxic chemical, including automotive, standard glycol antifreeze, or ethylene glycol made for hydronic (non-potable) systems. These chemicals can attack gaskets and seals in heaters, are poisonous if consumed, and can cause injury or death.

CAUTION

Consider piping and installation when determining heater location.

To winterize the heater, drain the entire system. Then apply air pressure to the drain valve and allow air and water to escape from the purge valve (see piping instructions).

Once you have evacuated as much water as possible, pump non-toxic, NSF food grade propylene glycol, FDA rated as GRAS (Generally Recognized As Safe), into the system. Consult the glycol manufacturer for specific instructions on concentration percentage as well as freeze and burst protection methods. Check the volume and concentration of antifreeze to assure protection is adequate to protect the entire system from freezing. When pumping, allow air and remaining water to escape from purge valve. When the stream coming out of the purge valve matches the color of the non-toxic glycol, the system is adequately filled.

Finally, it is recommended to start the circulation pump and allow the system to circulate for at 30 minutes to completely blend any trapped water that might be in the system with the glycol.

PART 2 – BEFORE YOU START

A. WHAT'S IN THE BOX

Also included with the heater:

- Temperature and Pressure Relief Valve
- Pressure and Temperature Gauge
- Intake PVC Tee with Screens
- Exhaust PVC Coupling with Screens
- Plastic hose and Instructions for Purging Heat Exchanger
- Installation Manual
- Warranty

B. HOW THE HEATER OPERATES

Modulation Condensing Technology is an intelligent system that delivers highly efficient water heating, while maximizing efficiency by measuring the data parameters of your system.

Stainless Steel Heat Exchanger

The highly efficient and durable stainless steel heat exchanger is designed to extract the last bit of energy from flue gas before it is exhausted.

Modulating Combustion System

Modulation during operation is based on supply temperature and desired temperature set point. The set point used for the control depends upon the programmed central heating curve. The heating curve slope can be changed by the installer to better fit system needs. The control monitors the system to regulate burner output during operation to match system demand. This increase in efficiency allows for substantial fuel savings.

Gas Valve

The gas valve senses suction from the blower, allowing gas to flow only if the gas valve is energized and combustion air is flowing.

Swirl Plate System

The gas valve swirl plate controls air and gas flow into the burner, assuring better mixing for improved combustion.

Supply Water Temperature Sensor

This sensor monitors heater output water temperature (system outlet/supply). The control module adjusts the heater firing rate so the outlet/supply temperature is correct.

Return Water Temperature Sensor

This sensor monitors the return water temperature (system inlet/return). The control module reduces or increases heater input, depending on how close the inlet/return water temperature is to the outlet water temperature.

Temperature and Pressure Gauge

Allows the user to monitor system temperature and pressure.

Control

The integrated control system monitors inlet/return and outlet/supply water temperature and regulates fan speed to regulate the unit's BTU output. This allows the unit to deliver the required amount of heated energy and nothing more.

Flue Pipe Adapter

The flue pipe adapter may be positioned so that the installer is able to find a position that will best facilitate the exhaust and combustion air pipe connections with the least number of elbows in even the most challenging of situations.

Burner

Constructed of metal fiber and high grade stainless steel, the burner uses pre-mixed air and gas and provides a wide range of firing rates.

Electrical Field Connections with Terminal Strips

The electrical cover plate allows access to the line voltage and low voltage terminal strips. Attach line voltage conduits to the three holes at the right of the line voltage terminal strip for power, CH pump and DHW pump. Route low voltage wires through the opening to the left of the low voltage terminal strip (see Field Wiring Instructions, Part 9).

Condensate Drain Connection

As this is a condensing high efficiency appliance, the unit has a condensate removal system. Condensate is nothing more than water vapor, derived from combustion products and similar to an automobile when it is initially started. It is very important that the condensate line slopes away from the heater and down to a suitable inside drain.

If the condensate outlet on the heater is lower than the drain, you must use a condensate removal pump (kit p/n 554200 available from HTP.) In addition, local authorities may require a condensate neutralizer to neutralize the condensate. Condensate neutralizers are made up of lime crystals, marble or phosphate chips. Neutralizers can be installed in the field by the installer and purchased from HTP (p/n N1100).

It is also very important not to expose the condensate line to freezing temperatures or any type of blockage. Plastic tubing must be the only material used for the condensate line. Steel, brass, copper or other materials will be subject to corrosion or deterioration. A second vent may be necessary to prevent condensate line vacuum lock on a long horizontal run. Also, an increase in pipe size may be necessary to allow condensate to drain properly. Support of the condensation line may be necessary to avoid blockage of the condensate flow.

Spark Ignition

The burner flame is ignited by applying a high voltage to the system spark electrode. This causes a spark from electrode to ground.

The Vision 1 Optional System

By controlling the temperature delivered to the central heating circuits based on outside temperature, the Vision 1 System allows the installer to take this highly efficient heater and make it even more efficient. The Vision 1 System is also a two temperature system, using one temperature for central heating and the other for use with an indirect water heater. This allows the user to increase the

temperature supplied to the indirect water heater to get a faster recovery by prioritizing the flow at a higher temperature than may be needed for the central heating circuits (this requires two separate circulators). You must follow the piping, wiring, and programming instructions located in the Vision One section of this manual.

C. OPTIONAL EQUIPMENT

Below is a list of optional equipment available from HTP. These additional options may be purchased through your HTP distributor:

- Indirect Tank Sensor (Part # 7250P-325)
- Outdoor sensor (Part # 7250P-319)
- 2" Stainless Steel Outside Termination Vent Kit (V500)
- 3" Stainless Steel Outside Termination Vent Kit (V1000)
- 2" PVC Concentric Vent Kit (Part # KGAVT0501CVT)
- 3" PVC Concentric Vent Kit (Part # KGAVT0601CVT)
- 3" Polypro Vent Kit (Part # 8400P-001)
- 3" Polypro Pipe (33' length Part # 8400P-002, 49.5' length Part # 8400P-003)
- Alarm System (Part # 7350P-602) (to monitor any failure)
- Condensate Pump (Part # 7250P-320)
- Condensate Neutralizer (Part # 554200)
- Vision 1 Outdoor Sensing System (Part # 7250P-622)

PART 3 – PREPARE HEATER LOCATION

CAUTION

Carefully consider installation when determining heater location. Please read the entire manual before attempting installation. Failure to properly take factors such as heater venting, piping, condensate removal, and wiring into account before installation could result in wasted time, money, and possible property damage and personal injury.

A. BEFORE LOCATING THE HEATER

⚠ WARNING

Incorrect ambient conditions can lead to damage to the heating system and put safe operation at risk. Ensure that the heater installation location adheres to the information included in this manual. Failure to do so could result in property damage, serious personal injury, or death.

CAUTION

Failure of heater or components due to incorrect operating conditions IS NOT covered by product warranty.

1. Installation Area (Mechanical Room) Operating Conditions

- Ensure ambient temperatures are higher than 32°F/0°C and lower than 104°F/40°C.
- Prevent the air from becoming contaminated by the products, places, and conditions listed in this manual, Part 3, Section F.
- Avoid continuously high levels of humidity
- Never close existing ventilation openings

CAUTION

The service life of the heater's exposed metallic surfaces, such as the casing, as well as internal surfaces, such as the heat exchanger, are directly influenced by proximity to damp and salty marine environments. In such areas, higher concentration levels of chlorides from sea spray coupled with relative humidity can lead to degradation of the heat exchanger and other heater components. In these environments, heaters must not be installed using direct vent systems which draw outdoor air for combustion. Such heaters must be installed using room air for combustion. Indoor air will have a much lower relative humidity and, hence, potential corrosion will be minimized.

⚠ WARNING

This heater is certified for indoor installations only. Do not install the heater outdoors. Failure to install this heater indoors could result in substantial property damage, severe personal injury, or death.

2. Check for nearby connections to:

- System water piping
- Venting connections
- Gas supply piping
- Electrical power

- Condensate drain

3. Check area around heater. Remove any combustible materials, gasoline, and other flammable liquids.

⚠ WARNING

Failure to keep heater area clear and free of combustible materials, liquids, and vapors can result in substantial property damage, severe personal injury, or death.

4. Gas control system components must be protected from dripping water during operation and service.

5. If the heater is to replace an existing heater, check for and correct any existing system problems, such as:

- System leaks
- Location that could cause the system and heater to freeze and leak.
- Incorrectly-sized expansion tank

6. Clean and flush system when reinstalling a heater.

NOTE: When installing in a zero clearance location, it may not be possible to read or view some product labeling. It is recommended to make note of the heater model and serial number.

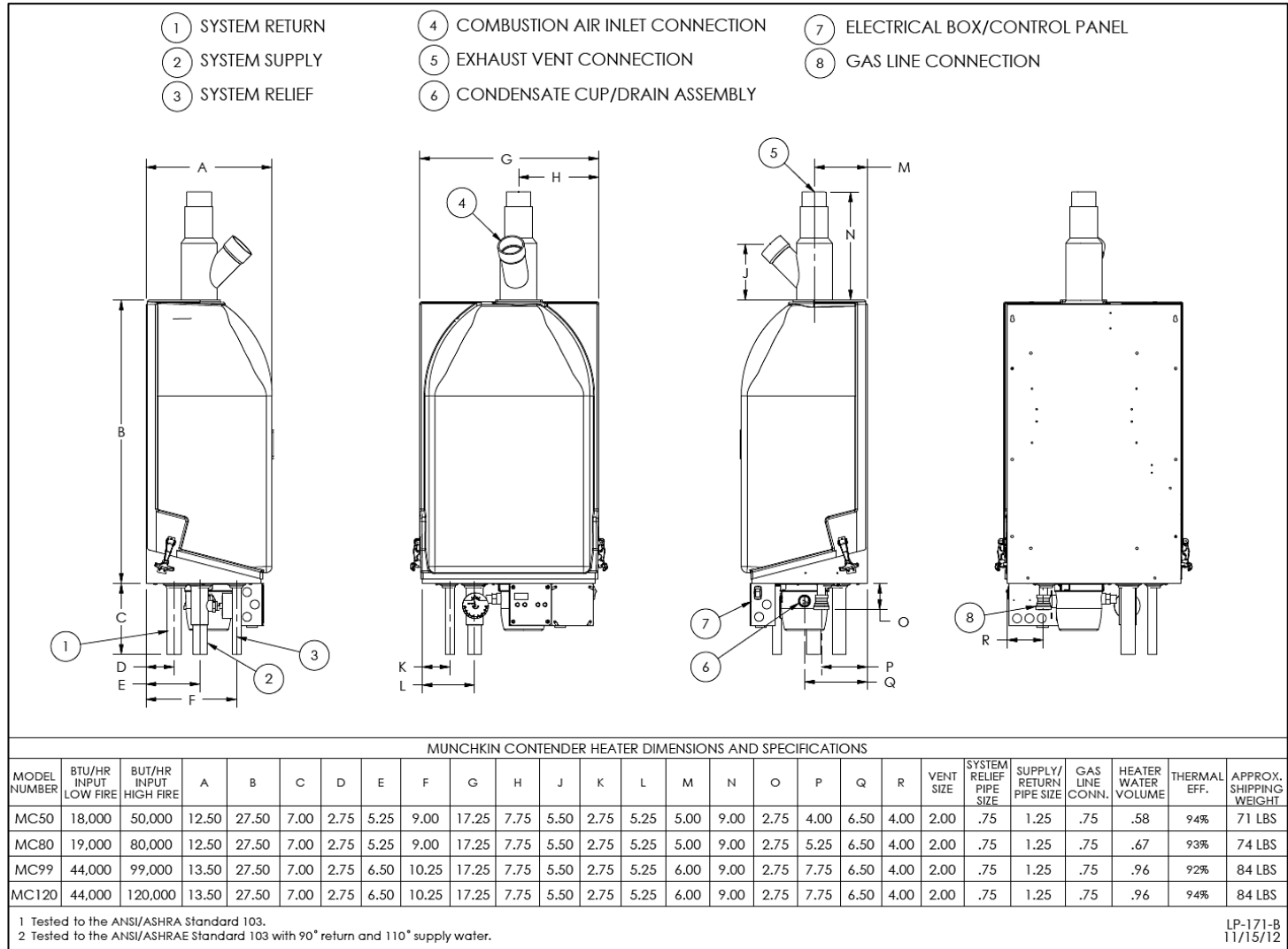

Figure 1 –Specifications – LP-171-B

Before considering location, many factors need to be addressed. Piping, Venting, and Condensation Removal are just a few of the issues that need attention prior to the installation of the heater. Please read the entire manual, as it could save time and money.

B. LEVELING**⚠ CAUTION**

In order for the condensate to properly flow out of the collection system, the heater must be installed level. The location must also support the heater when it is full of water.

C. CLEARANCES FOR SERVICE ACCESS

See Figure 2 for recommended service clearances. If you do not provide the minimum clearances shown, it may not be possible to service the heater without removing it from the space.

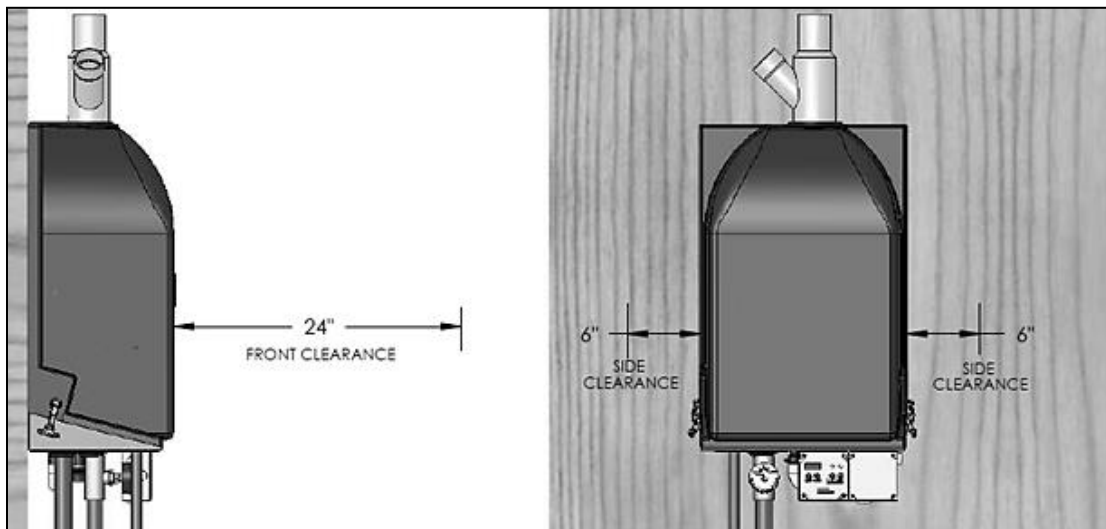

Figure 2 – Required Clearances

⚠ WARNING

Space must be provided with combustion/ventilation air openings correctly sized for all other appliances located in the same space as the heater. The heater cover must be securely fastened to prevent the heater from drawing air from the heater room. This is particularly important if the heater is in a room with other appliances. Failure to comply with the above warnings could result in substantial property damage, severe personal injury, or death.

D. RESIDENTIAL GARAGE, CLOSET, AND ALCOVE INSTALLATIONS**CAUTION**

Check with your local Authority Having Jurisdiction for requirements when installing heater in a garage, closet, or alcove. Please read the entire manual before attempting installation. Failure to properly take factors such as heater venting, piping, condensate removal, and wiring into account before installation could result in wasted time, money, and possible property damage and personal injury.

PRECAUTIONS

If the heater is located in a residential garage, per ANSI Z223.1:

- Mount the bottom of the heater a minimum of 18" above the floor of the garage, to ensure the burner and ignition devices are well off the floor.
- Locate or protect the heater so it cannot be damaged by a moving vehicle.

⚠ WARNING

For closet or alcove installations, a two pipe venting system must be used. Failure to follow this warning could result in substantial property damage, severe personal injury, or death.

⚠ WARNING

The space must be provided with correctly sized combustion/ventilation air openings for all other heaters located in the space with the heater. Do not install the heater in an attic. Failure to comply with these warnings could result in substantial property damage, severe personal injury, or death.

NOTE: For installations using room air for combustion, refer to the heater venting section, Part 6 in this manual.

E. EXHAUST VENT AND INTAKE PIPE

The appliance is rated ANSI Z21.13 Category IV (pressurized vent, likely to form condensate in the vent) and requires a special vent system designed for pressurized venting.

NOTE: The venting options described here (and further detailed in the Venting section of this manual) are the lone venting options approved for this appliance. Failure to vent the appliance in accordance with the provided venting instructions will void the warranty.

 DANGER
Failure to vent the appliance properly will result in serious personal injury or death.

 WARNING
Vents must be properly supported. Appliance exhaust and intake connections are not designed to carry heavy weight. Vent support brackets must be within 1' of the appliance and the balance at 4' intervals. Appliance must be readily accessible for visual inspection for the first 3' from the appliance.

DIRECT VENT INSTALLATION OF EXHAUST VENT AND INTAKE PIPE

When installing a direct vent, combustion air must be drawn from the outdoors directly into the appliance intake, and exhaust must terminate outside. There are two basic direct vent options detailed in this manual: 1. Side Wall Venting and 2. Roof Venting.

Be sure to locate the appliance such that the exhaust vent and intake piping can be routed through the building and properly terminated. Different vent terminals can be used to simplify and eliminate multiple penetrations in the building structure (see Optional Equipment in Venting Section). The exhaust vent and intake piping lengths, routing and termination methods must all comply with the methods and limits given in the Venting section of this manual.

When installing a combustion air intake from outdoors, care must be taken to utilize uncontaminated combustion air. **NOTE: To prevent combustion air contamination, see Table 1.**

 WARNING
Do not attempt to vent this appliance by any means other than those described in this manual. Doing so will void the warranty, and may result in severe personal injury or death.

F. PREVENT COMBUSTION AIR CONTAMINATION

Install intake air piping for the heater as described in the Venting section. Do not terminate exhaust in locations that can allow contamination of intake air.

PRODUCTS TO AVOID	AREAS LIKELY TO HAVE CONTAMINANTS
Spray cans containing fluorocarbons	Dry cleaning/laundry areas and establishments
Permanent wave solutions	Swimming pools
Chlorinated waxes/cleaners	Metal fabrication plants
Chlorine-based swimming pool chemicals	Beauty shops
Calcium chloride used for thawing	Refrigeration repair shops
Sodium chloride used for water softening	Photo processing plants
Refrigerant leaks	Auto body shops
Paint or varnish removers	Plastic manufacturing plants
Hydrochloric or Muriatic acid	Furniture refinishing areas and establishments
Cements and glues	New building construction
Antistatic fabric softeners used in clothes dryers	Remodeling areas
Chlorine-type bleaches, laundry detergents, and cleaning solvents	Garages and workshops
Adhesives used to fasten building products	

Table 1 - Contaminant Table

 WARNING
You must pipe outside air to the heater air intake. Ensure that the intake air will not contain any of the contaminants listed in Table 1. For example, do not pipe intake near a swimming pool. Also, avoid areas subject to exhaust fumes from laundry facilities. These areas always contain contaminants. Contaminated air will damage the heater, resulting in possible substantial property damage, severe personal injury, or death.

NOTE: DAMAGE TO THE HEATER CAUSED BY EXPOSURE TO CORROSIVE VAPORS IS NOT COVERED BY WARRANTY.
(Refer to the limited warranty for complete terms and conditions).

G. REMOVING AN EXISTING HEATER FROM AN EXISTING COMMON VENT SYSTEM

⚠ DANGER

Do not install the heater into a common vent with any other appliance. This will cause flue gas spillage or appliance malfunction, resulting in possible substantial property damage, severe personal injury, or death.

⚠ WARNING

Failure to follow all instructions can result in flue gas spillage and carbon monoxide emissions, causing severe personal injury or death.

When removing an existing heater, follow the steps below with each appliance remaining connected to the common venting system in operation, while other appliances remaining connected to common venting system are not operating.

1. Seal any unused openings in the common venting system.
2. Visually inspect the venting system for proper size and horizontal pitch to determine if there is blockage, leakage, corrosion or other deficiencies that could cause an unsafe condition.
3. If practical, close all building doors, windows and all doors between the space in which the appliance remains connected to the common venting system located and other spaces in the building. Turn on clothes dryers and any appliances not connected to the common venting system. Turn on any exhaust fans, such as range hoods and bathroom exhausts, at maximum speed. Do not operate a summer exhaust fan. Close all fireplace dampers.
4. Place in operation the appliance being inspected. Follow the lighting instructions. Adjust the thermostat so the appliance will operate continuously.
5. Test for spillage at the draft hood relief opening after 5 minutes of main burner operation. Use the flame of a match or candle or smoke from a cigarette.
6. After it has been determined that each appliance remaining connected to common venting system properly vents when tested as outlined, return doors, windows, exhaust fans, fireplace dampers and any other gas burning appliance to their previous condition of use.
7. Any improper operation of the common venting system should be corrected to conform to the National Fuel Gas Code, ANSI Z223.1. When resizing any portion of the common venting system, the system should approach the minimum size as determined using the appropriate tables in Appendix G in the National Fuel Gas Code, ANSI Z 223.1.

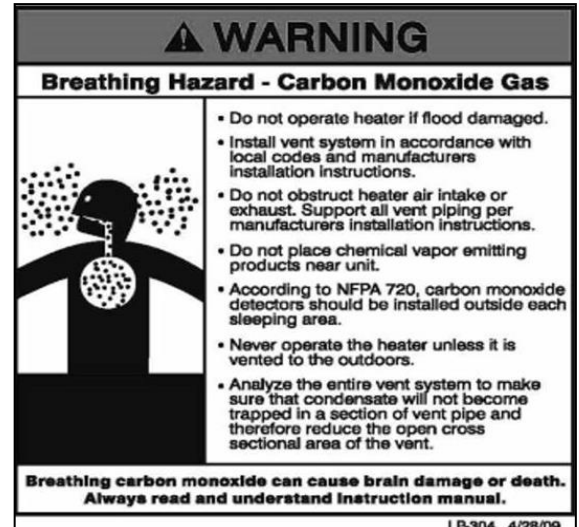

Figure 3

PART 4 – PREPARE HEATER

⚠ WARNING

UNCRATING HEATER – Any claims for damage or shortage in shipment must be filed immediately against the transportation company by the consignee.

⚠ CAUTION

COLD WEATHER HANDLING – If the heater has been stored in a very cold location (BELOW 0°F) before installation, handle with care until the plastic components come to room temperature.

A. REMOVE HEATER FROM BOX

The heater is easy to handle. Care must be taken to place it in a safe location prior to installation to prevent damage to the bottom mechanical connections.

B. WALL MOUNTING CONSIDERATIONS

These heaters are wall mounted. Use only the wall mounting instructions included in installation envelope.

⚠ WARNING

The wall must be capable of carrying the weight of the heater and its related components. The weights of the heaters are approximately:

MC-50 – 71 lbs MC-80 – 74 lbs
MC-99 – 84 lbs MC-120 – 84 lbs

Failure to comply with above could result in substantial property damage, severe personal injury, or death.

C. WALL MOUNTING INSTRUCTIONS

⚠ WARNING

This heater is heavy and awkward to lift. It is recommended and safer to install the heater with two people. Use caution as to not drop the heater, which could damage the heater and cause property damage and/or personal injury. Verify that the heater is securely mounted before leaving unsupervised. Failure to comply with the above and properly mount the heater could result in substantial property damage, severe personal injury, or death.

The wall must be vertically plumb and capable of carrying the weight of the heater and its related components.

The building frame (studs) must be 16" on center. If not, you must use 1/2" minimum plywood 24" x 48", fastened with at least (14) #12 x 3" (3/16" x 3") round head tapping screws to the frame of the building to provide proper support for the heater. Alternate methods of mounting must not be used. (ex. toggle bolts, hollow wall anchors) or any other fastener other than #12 x 3" (3/16" x 3") round head tapping screws.

CAUTION

If the heater is not vertically plumb, improper and unsatisfactory operation may occur, causing excessive condensation build-up, nuisance fault codes, and unnecessary maintenance.

D. INSTALLATION STEPS

1. Prior to lifting the heater onto the wall, use the enclosed template to level and locate the 2 primary (#12 x 3" [3/16" x 3"]) round head tapping screws, leaving about 1/4" between the screw head and the wall surface to allow for access to the keyway slot located in the back of the heater panel. It is extremely important that the line on the template is level when locating the first 2 screws. Failure to do so will result in an uneven or out of level installation.
2. Remove the heater cover. Locate the 2 keyway slots over the screws. Then lower the heater onto the smallest part of the keyway slot.
3. Once the heater is mounted on the first 2 screws, finish tightening the screws to the back panel. Then install the 6 additional screws of the same size to the back panel holes. This will provide additional strength and support to the heater.

PART 5 – HEATER PIPING

⚠ WARNING

Failure to follow the instructions in this section WILL VOID the warranty and may result in property damage, serious injury, or death.

CAUTION

Never use dielectric unions or galvanized steel fittings when connecting to a stainless steel storage tank or heater. Use only copper or brass fittings. Teflon thread sealant must be used on all connections. All piping and components connected to the heater must be approved for potable water systems.

Plumbing of this product should only be done by a qualified, licensed plumber in accordance with all local plumbing codes. The heater may be connected to a storage tank to supply domestic hot water. HTP offers 60/80/119/175 gallon size storage tanks in either stainless steel or glass-lined construction. These storage tanks can be directly connected to the heater supply and return connection.

CAUTION

The National Standard Plumbing Code, the National Plumbing Code of Canada, and the Uniform Plumbing Code limit the pressure of the heat transfer fluid to less than the minimum working pressure of the potable water system up to 30 psi maximum. The heat transfer fluid must be water or other non-toxic fluid having a toxicity of Class 1, as listed in Clinical Toxicology of Commercial Products, 5th Edition.

A. GENERAL PIPING INFORMATION**CAUTION**

The building piping system must meet or exceed the piping requirements in this manual.

CAUTION

Use two wrenches when tightening water piping at heater. Use one wrench to prevent the heater return or supply line from turning. Failure to prevent piping connections from turning could cause damage to heater components.

1. The water supply should be shut off while connecting the heater. A manual control valve must be placed on the inlet connection to the heater. Unions can be used on both the hot and cold water lines for future servicing and disconnection of the unit.
2. Purge the water line to remove all debris and air. Debris will damage the water heater.
3. If the heater is to be used as a potable water source, it must not be connected to a system that was previously used for non-potable purposes.
4. Ensure that the water filter on the heater is clean and installed.
5. New plumbing typically has contamination in the lines. Please flush the system before connection.

CAUTION

The heater control module uses temperature sensors to provide both high limit protection and modulating temperature control. The control module also provides low water protection by sensing the water pressure. Some codes/jurisdictions may require additional external controls.

B. RELIEF VALVE

The relief valve must comply with the standard for *Relief Valves and Automatic Gas Shutoff Devices for Hot Water Supply Systems (ANSI Z21.22)* and/or the standard *Temperature, Pressure, Temperature and Pressure Relief Valves and Vacuum Relief Valves, CAN1-4.4*, as well as all local codes. In addition, the relief valve must be rated to the maximum BTU/hr rating of the heater.

The *American National Standard (ANSI Z21.10.3) / Canadian Standard (CSA 4.3)* do not require a combination temperature and pressure relief valve for this heater. However, a combination temperature and pressure relief valve may be required by local codes.

Connect discharge piping to safe disposal location. See the following guidelines.

 WARNING

To avoid water damage or scalding due to relief valve operation:

- Discharge line must be connected to relief valve outlet and run to a safe place of disposal. Terminate the discharge line in a manner that will prevent possibility of severe burns or property damage should the relief valve discharge.
- Discharge line must be as short as possible and the same size as the valve discharge connection throughout its entire length.
- Discharge line must pitch downward from the valve and terminate at least 6" above the floor drain, making discharge clearly visible.
- The discharge line shall terminate plain, not threaded, with a material serviceable for temperatures of 375°F or greater.
- Do not pipe discharge to any location where freezing could occur.
- No shutoff valve may be installed between the relief valve and heater or in the discharge line. Do not plug or place any obstruction in the discharge line.
- Test the operation of the relief valve after filling and pressurizing the system by lifting the lever. Make sure the valve discharges freely. If the valve fails to operate correctly, immediately replace with a new properly rated relief valve.
- Test relief valve at least once annually to ensure the waterway is clear. If valve does not operate, turn the heater "off" **and call a plumber immediately.**
- Take care whenever operating relief valve to avoid scalding injury or property damage.
- For heaters installed with only a pressure relief valve, the separate storage vessel must have a temperature and pressure relief valve installed. This relief valve shall comply with *Relief Valves for Hot Water Supply Systems, ANSI Z21.22 / CSA4.4.*

FAILURE TO COMPLY WITH THE ABOVE GUIDELINES COULD RESULT IN FAILURE OF RELIEF VALVE OPERATION, RESULTING IN POSSIBILITY OF SUBSTANTIAL PROPERTY DAMAGE, SEVERE PERSONAL INJURY, OR DEATH.

 WARNING

Hot water outlet pipes can be hot to touch. Insulation must be used for hot water pipes below 36" to protect children against injuries due to scalds.

NOTE: If a relief valve discharges periodically, this may be due to thermal expansion in a closed water supply system. **DO NOT PLUG THE RELIEF VALVE.** An expansion tank may be required.

APPROXIMATE TIME / TEMPERATURE RELATIONSHIPS IN SCALDS	
120°F	More than 5 minutes
125°F	1 ½ to 2 minutes
130°F	About 30 seconds
135°F	About 10 seconds
140°F	Less than 5 seconds
145°F	Less than 3 seconds
150°F	About 1 ½ seconds
155°F	About 1 second

Table 2

⚠ DANGER

⚠ DANGER Water temperature over 125 degrees F. can cause severe burns instantly, or death from scalds. Children, disabled, and elderly are at highest risk of being scalded. See instruction manual before setting temperature at water heater. Feel water before bathing or showering! Temperature limiting valves are available. See chart below showing temperature burn rate.



⚠ DANGER



C. SEPARATE LOW WATER CUTOFF

A low water cutoff may be required by state and local codes, or by some insurance companies. A low water cutoff is also required if the heater is installed above the piping level. Check code requirements before installing the heater.

If required:

- Use an electrode probe type low water cutoff designed for hydronic installations.
- Install in a tee on the supply piping above the heater.
- Follow low water cutoff manufacturer’s instructions.

D. BACKFLOW PREVENTER

Use a backflow preventer specifically designed for hydronic heater installations. This valve should be installed on the cold water fill supply line per local codes. (See piping details at the end of this section.)

CAUTION

All piping methods shown in this manual use primary/secondary connection to the heater loop. This is to avoid the possibility of noise or actuator problems in zone valves because of the high-head heater circulator. For other piping methods, consult your local HTP representative or refer to separate piping details in this manual.

E. SYSTEM WATER PIPING METHODS

EXPANSION TANK AND MAKE-UP WATER

1. Ensure expansion tank size will handle heater and system water volume and temperature. Allow 3 gallons for the heater and its piping.

⚠ WARNING

Expansion tanks must be sized according to total system volume. This includes all length of pipe, all fixtures, appliances, etc. Failure to properly size system expansion could result in wasted time, money, and possible property damage, personal injury, or death.

CAUTION

Undersized expansion tanks cause system water to be lost from relief valve and make-up water to be added through fill valve. Eventual failure can result due to excessive make-up water addition. **SUCH FAILURE IS NOT COVERED BY WARRANTY.**

2. Expansion tank must be located as shown in Piping diagrams, or following recognized design methods. See tank manufacturer’s instructions for details.

3. Connect the expansion tank to the air separator only if the separator is on the suction side of the circulator. Always install the system fill connection at the same point as the expansion tank connection to the system.

4. Most chilled water systems are piped using a closed type expansion tank.

CAUTION

DO NOT install automatic air vents on closed-type expansion tank systems. Air must remain in the system and return to the tank to provide its air cushion. An automatic air vent would cause air to leave the system, resulting in water-logging the expansion tank.

DIAPHRAGM (OR BLADDER) EXPANSION TANK

Always install an automatic air vent on top of the air separator to remove residual air from the system.

F. CIRCULATORS

CAUTION

DO NOT use the heater circulator in any location other than the ones shown in this manual. The heater circulator is selected to ensure adequate flow through the heater. Failure to do so could result in unreliable performance and nuisance shutdowns from insufficient flow.

SIZING SPACE HEAT SYSTEM PIPING

1. See Piping Details in this section. In all diagrams, the space heating system is isolated from the heating loop by the primary/secondary connection.

2. Size the piping and components in the space heating system using recognized design methods.

G. HYDRONIC PIPING WITH CIRCULATORS, ZONE VALVES, AND MULTIPLE HEATERS

This heater may function in a closed loop 15 psi system. An optional water pressure switch ensures adequate pressure in the system. The heater will not operate without a minimum of 10 psi water pressure. This assures you that if the system does have a leak, the heater will lock out (PRO on the display) before it damages the heat exchanger.

The included temperature and pressure gauge allows the user to monitor the system pressure and outlet temperature from the heater. It is important to note that the heater has a minimal amount of pressure drop that must be calculated when sizing the circulators. Each installation must also have an air elimination device that will remove air from the system.

Observe minimum 1" clearance around all un-insulated hot water pipes when openings around pipes are not protected by non-combustible materials. On a heater installed above radiation level, some states and local codes require a low water cut off device (See Part C this section). If the heater supplies hot water to heating coils in air handler units, flow control valves or other devices must be installed to prevent gravity circulation of heater water in the coils during the cooling cycle. Chilled water medium must be piped in parallel with the heater.

CAUTION

The heater should not be operated as a potable hot water heater. Operating this heater as a potable water heater will VOID warranty.

1. Connect the system return marked "Heater In".
2. Connect the system supply marked "Heater Out".
3. Install purge and balance valve or shut off valve and drain on system return to purge air out of each zone.
4. Install a back flow preventer on the cold feed make-up water line.
5. Install a pressure reducing valve on the cold feed make-up water line, (15 psi nominal on the system return). Check temperature and pressure gauge, which should read minimum pressure of 12 psi.
6. Install a circulator as shown in piping details (this section). Make sure the circulator is properly sized for the system and friction loss.
7. Install an expansion tank on the system supply. Consult the tank manufacturer's instruction for specific information relating to expansion tank installation. Size the expansion tank for the required system volume and capacity.
8. Install an air elimination device on the system supply.
9. Install a drain valve at the lowest point of the system. NOTE: The heater cannot be drained completely of water without purging the unit with an air pressure 15 psi.
10. The safety relief valve is installed at the factory. Pipe the discharge of the safety relief valve to prevent injury in the event of pressure relief. Pipe the discharge 6" above the drain to a drain. Provide piping that is the same size as the safety relief valve outlet. **Never block the outlet of safety relief valve.**

H. CIRCULATOR SIZING

The heat exchanger has a minimum total water volume that must be taken into account when sizing the circulator. These minimum water volumes are listed in Table 3 below.

MINIMUM BOILER FLOW RATES	
MODEL	MINIMUM FLOW (GPM)
MC-50	3.3
MC-80	5.3
MC-99	7.8
MC-120	8

Table 3 – Minimum Heat Exchanger Water Volumes

In addition, the heat exchanger has pressure drop which must be considered in your system design. Refer to the graph in Figure 4 for pressure drop through the heat exchanger for recommended pump selection at a 20Δt design.

The chart below represents various system temperatures and their respective flows and friction loss through the heater, which will aid circulator selection.

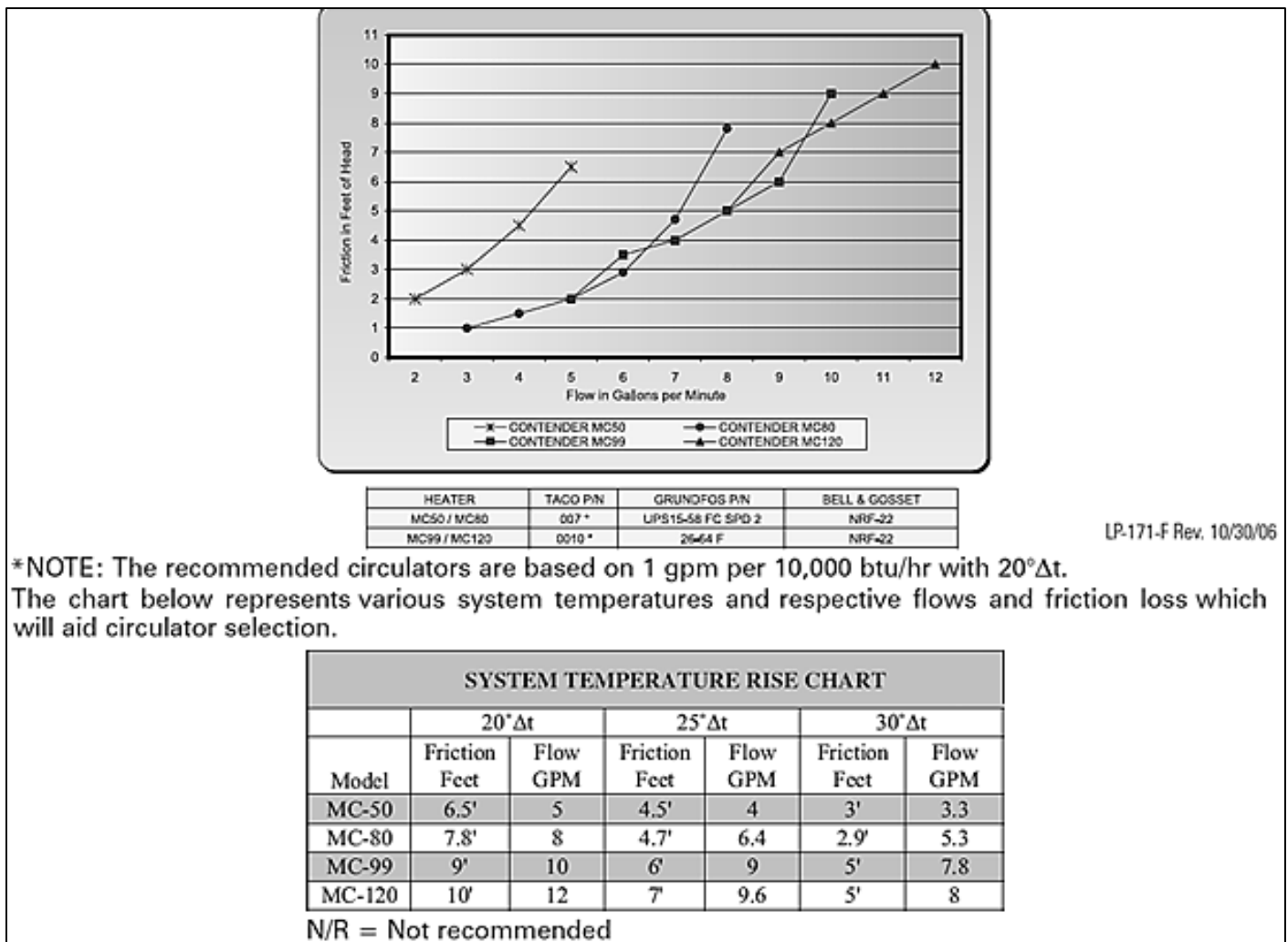

Figure 4 – Pressure Drop Graph and Temperature Rise Chart – LP-171-F NOTE: The recommended circulators are based on 1 gpm per 10,000 btu/hr with 20Δt.

I. ZONING WITH ZONE VALVES

1. Connect heater to system as shown in 1A and 1B in Piping Details when zoning with zone valves. The primary/secondary piping shown ensures the heater loop will have sufficient flow. It also avoids applying the high head of the heater circulator to the zone valves.
2. Connect DHW (domestic hot water) piping to indirect storage water heater as shown.

J. ZONING WITH CIRCULATORS

1. Connect heater to system when circulator zoning as shown in 1C and 1D in Piping Details when zoning with circulators. The heater circulator cannot be used for a zone. It must supply only the heater loop. Install a separate circulator for each zone.
2. Connect DHW (domestic hot water) piping to indirect storage water heater as shown.

K. MULTIPLE HEATERS

1. Connect multiple heaters as shown in 1E and 1F in Piping Details.
2. All piping shown is reverse return to assure balanced flow through the connected heaters.
3. Each connected heater must have its own circulator pump to assure adequate flow.
4. Connect DHW (domestic hot water) piping to indirect storage water heater as shown.

L. FILL AND PURGE HEATING SYSTEM

- Attach the hose to balance and purge hose connector or drain valve and run hose to nearest drain.
- Close the other side of the balance and purge valve or the shut off valve after the drain.
- Open first zone balance and purge or drain valve to let water flow out the hose. If zone valves are used, open the valves one at a time manually. (NOTE: You should check valve manufacturer's instruction prior to opening valves manually, so as not to damage the valve.)
- Manually operate fill valve regulator. When water runs out of the hose, while it's connected to the balance and purge valve or drain you will see a steady stream of water (without bubbles). Close balance and purge valve or drain to stop the water from flowing. Disconnect the hose and connect it to next zone to be purged.
- Repeat this procedure for additional zones (one at time).

CAUTION

For installations that incorporate standing iron radiation and systems with manual vents at the highest points: Follow the above section and, starting with the nearest manual vent, open until water flows out. Then close vent. Repeat procedure, working your way toward furthest air vent. It may be necessary to install a basket strainer in an older system where larger amounts of sediment may be present. Annual cleaning of the strainer may be necessary.

Upon completion, make sure that the fill valve is in automatic position and each zone balance and purge or shut off is in an open position and zone valves are positioned for automatic operation.

WARNING

Use only inhibited propylene glycol solutions, specially formulated for hydronic systems. Ethylene glycol is toxic and can attack gaskets and seals used in hydronic systems. Glycol mixtures should not exceed 50%.

1. Glycol for hydronic applications includes inhibitors that prevent it from attacking metallic system components. Make certain that the system fluid is checked for the correct glycol concentration and inhibitor level.
2. The glycol solution should be tested at least once a year and as recommended by the glycol manufacturer.
3. Anti-freeze solutions expand more than water. For example a 50% by volume solution expands 4.8% in volume for a temperature increase from 32° F to 180° F, while water expands 3% with the same temperature rise. Allowances must be made for this expansion in the system design.
4. A 30% mixture of glycol will result in 15% BTU output loss and a 5% increase in head against system circulator.
5. A 50% mixture of glycol will result in 30% BTU output loss and a 50% increase in head against system circulator.

CAUTION

It is highly recommended that you carefully follow the glycol manufacturer's concentrations, expansion requirements, and maintenance recommendations (pH additive breakdown, inhibitor reduction, etc.) You must carefully figure the additional system friction loss, as well as the reduction in heat transfer coefficients.

M. PIPING DETAILS

Piping symbol legend

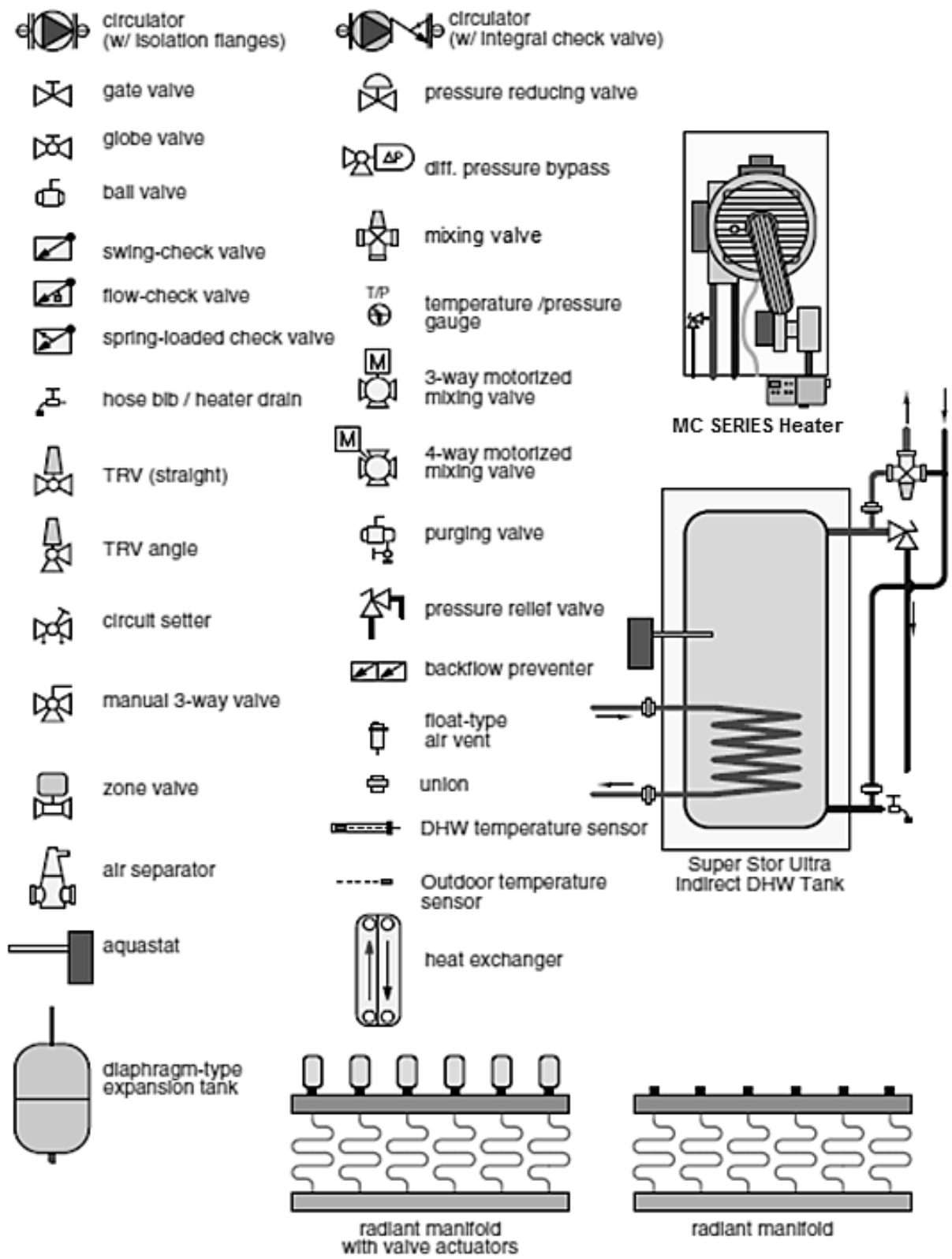

Figure 5

Standard MC Series Heater (zoning with valves) Space heating mode

Drawing 1A

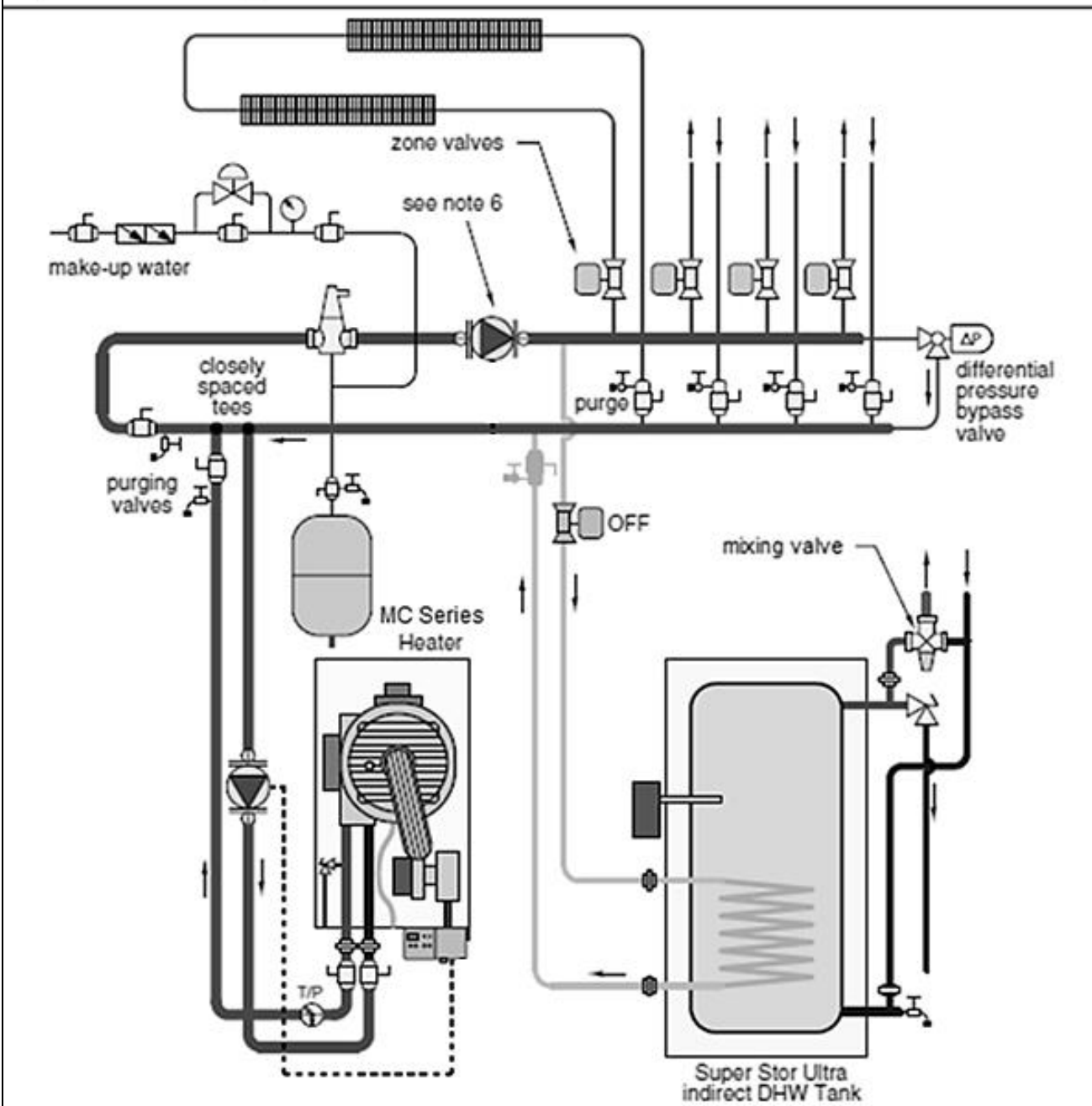

Figure 6

NOTES:

1. This drawing is meant to demonstrate system piping concept only. Installer is responsible for all equipment and detailing required by local codes.
2. All closely spaced tees shall be within 4 pipe diameters center to center spacing.
3. A minimum of 6 pipe diameters of straight pipe shall be installed upstream and downstream of all closely spaced tees.
4. The **minimum** pipe size for connecting an indirect water heater is 1".
5. The **minimum** pipe size for connecting the unit is 1.25".
6. Circulators are shown with isolation flanges. The alternative is standard flanges with full port ball valves. Purge valves can be used with the circulator flanges as an alternative.
7. The anti-scald mixing valve is recommended if the DHW temperature is set above the factory setting of 119°F.
8. Install a minimum of 12 diameters of straight pipe upstream of all circulators.
9. **Winterization:** When winterizing the unit, put a drain valve on both the supply and return between the union and the shut-off connection.

Standard MC Series Heater (zoning with valves) Domestic water heating mode

Drawing 1B

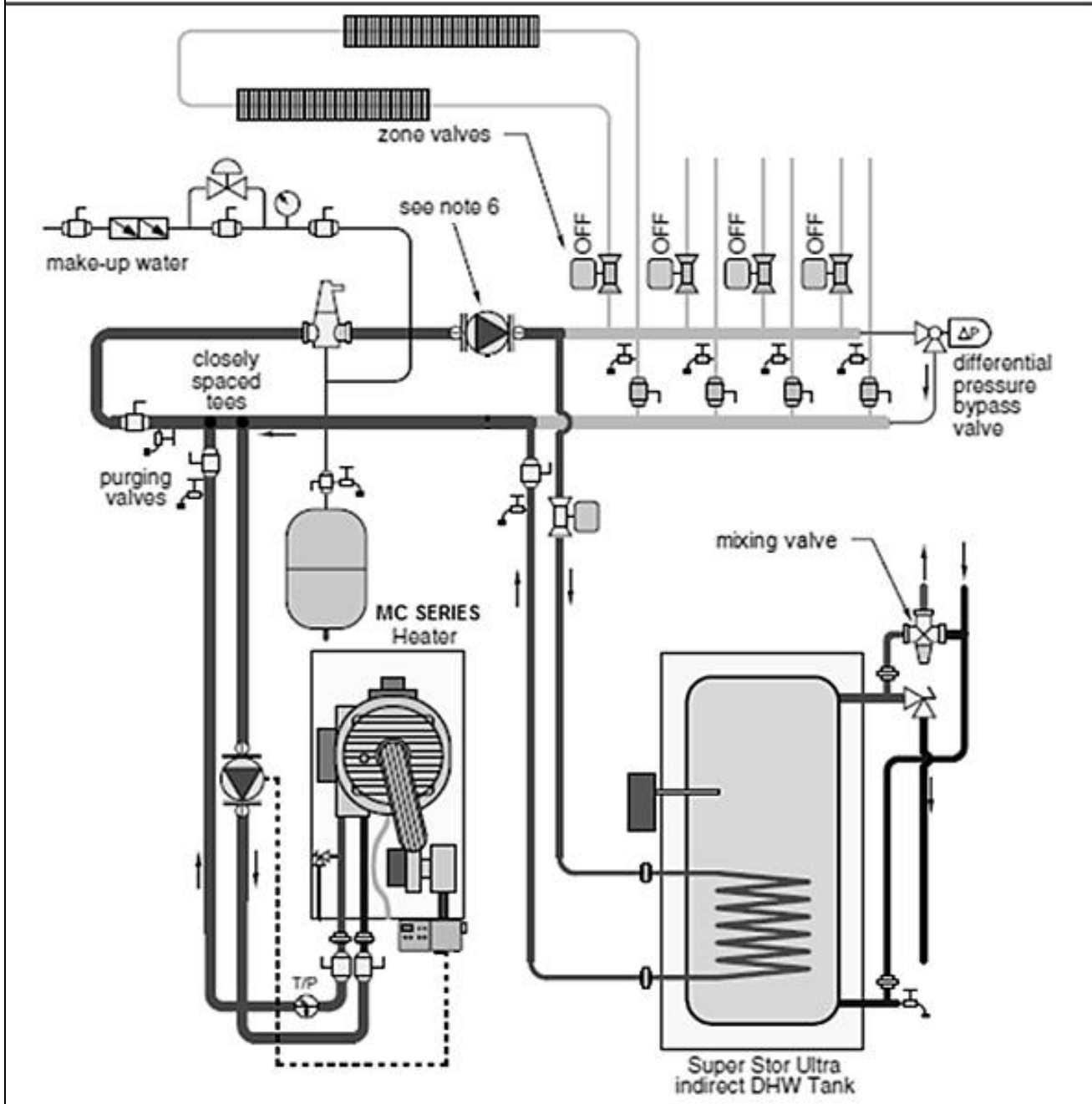

Figure 7

NOTES:

1. This drawing is meant to demonstrate system piping concept only. Installer is responsible for all equipment and detailing required by local codes.
2. All closely spaced tees shall be within 4 pipe diameters center to center spacing.
3. A minimum of 6 pipe diameters of straight pipe shall be installed upstream and downstream of all closely spaced tees.
4. The **minimum** pipe size for connecting an indirect water heater is 1".
5. The **minimum** pipe size for connecting the unit is 1.25".
6. Circulators are shown with isolation flanges. The alternative is standard flanges with full port ball valves. Purge valves can be used with the circulator flanges as an alternative.
7. The anti-scald mixing valve is recommended if the DHW temperature is set above the factory setting of 119°F.
8. Install a minimum of 12 diameters of straight pipe upstream of all circulators.
9. **Winterization:** When winterizing the unit, put a drain valve on both the supply and return between the union and the shut-off connection.

Standard MC Series Heater Preferred piping (zoning with circulators) Space heating mode

Drawing 1C

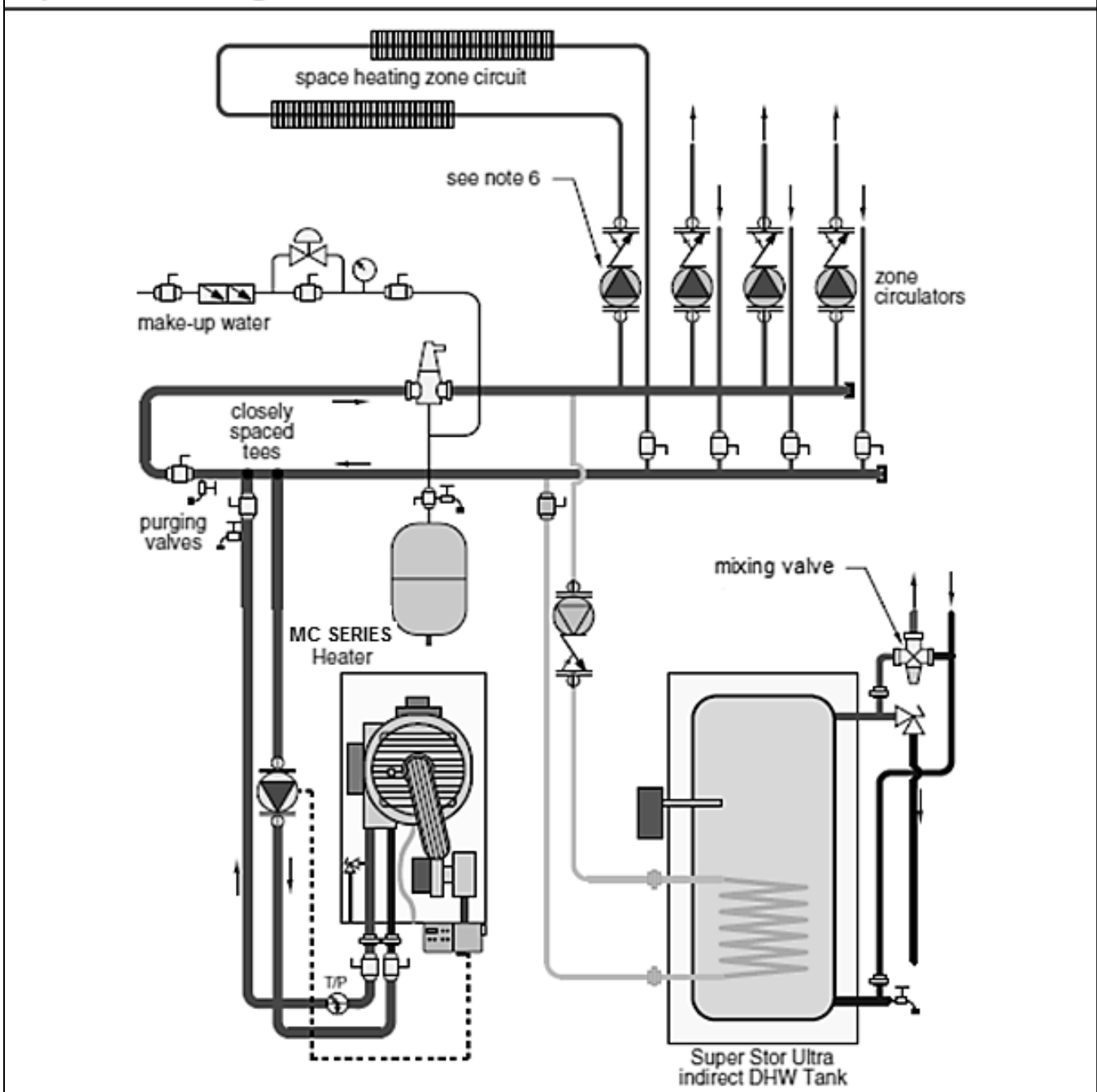

Figure 8

NOTES:

1. This drawing is meant to demonstrate system piping concept only. Installer is responsible for all equipment and detailing required by local codes.
2. All closely spaced tees shall be within 4 pipe diameters center to center spacing.
3. A minimum of 6 pipe diameters of straight pipe shall be installed upstream and downstream of all closely spaced tees.
4. The **minimum** pipe size for connecting an indirect water heater is 1".
5. The **minimum** pipe size for connecting the unit is 1.25".
6. Circulators are shown with isolation flanges. The alternative is standard flanges with full port ball valves. Purge valves can be used with the circulator flanges as an alternative.
7. The anti-scald mixing valve is recommended if the DHW temperature is set above the factory setting of 119°F.
8. Install a minimum of 12 diameters of straight pipe upstream of all circulators.
9. **Winterization:** When winterizing the unit, put a drain valve on both the supply and return between the union and the shut-off connection.

Standard MC Series Heater (zoning with circulators) Domestic water heating mode

Drawing 1D

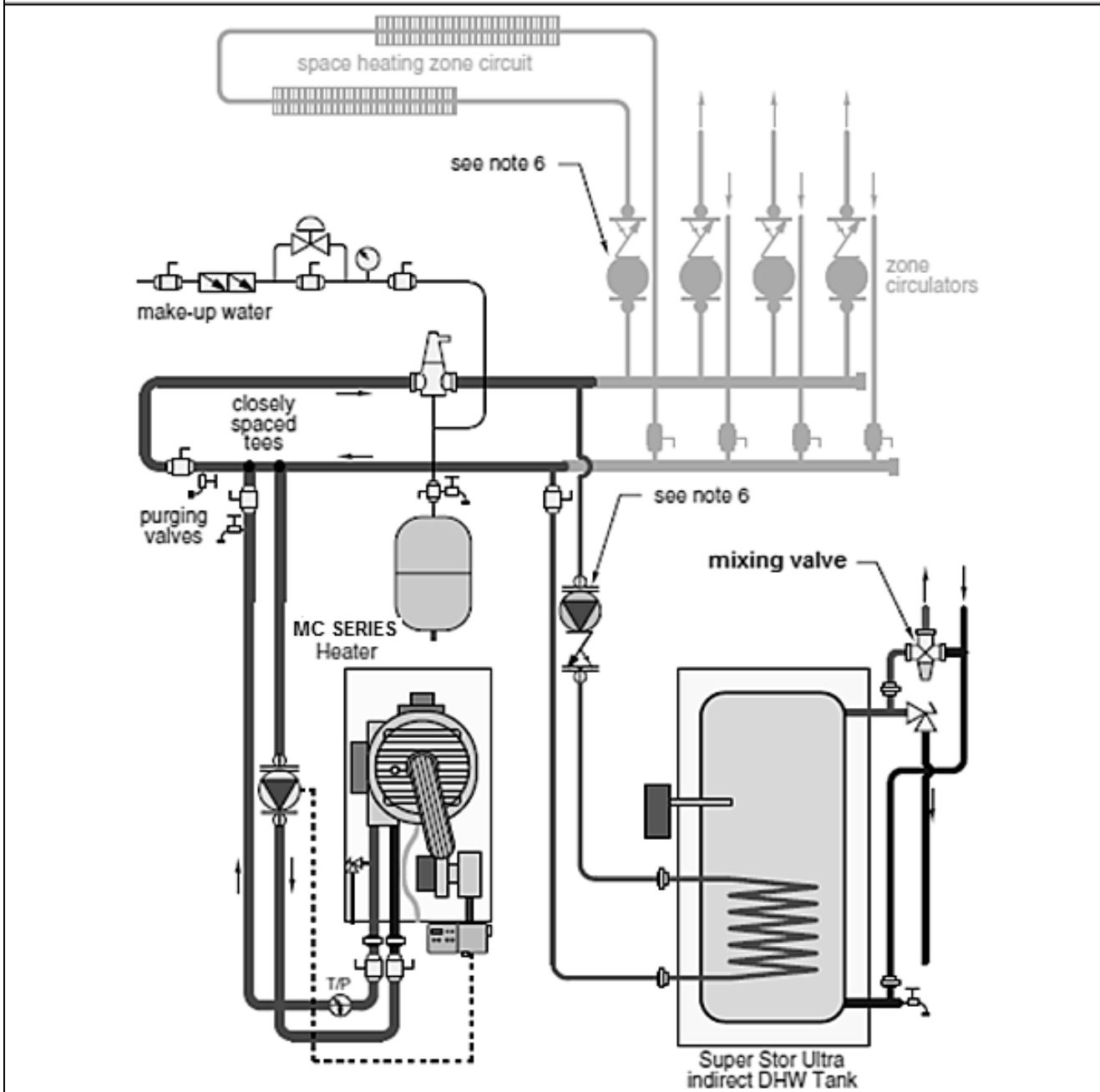

Figure 9

NOTES:

1. This drawing is meant to demonstrate system piping concept only. Installer is responsible for all equipment and detailing required by local codes.
2. All closely spaced tees shall be within 4 pipe diameters center to center spacing.
3. A minimum of 6 pipe diameters of straight pipe shall be installed upstream and downstream of all closely spaced tees.
4. The **minimum** pipe size for connecting an indirect water heater is 1".
5. The **minimum** pipe size for connecting the unit is 1.25".
6. Circulators are shown with isolation flanges. The alternative is standard flanges with full port ball valves. Purge valves can be used with the circulator flanges as an alternative.
7. The anti-scald mixing valve is recommended if the DHW temperature is set above the factory setting of 119°F.
8. Install a minimum of 12 diameters of straight pipe upstream of all circulators.
9. **Winterization:** When winterizing the unit, put a drain valve on both the supply and return between the union and the shut-off connection.

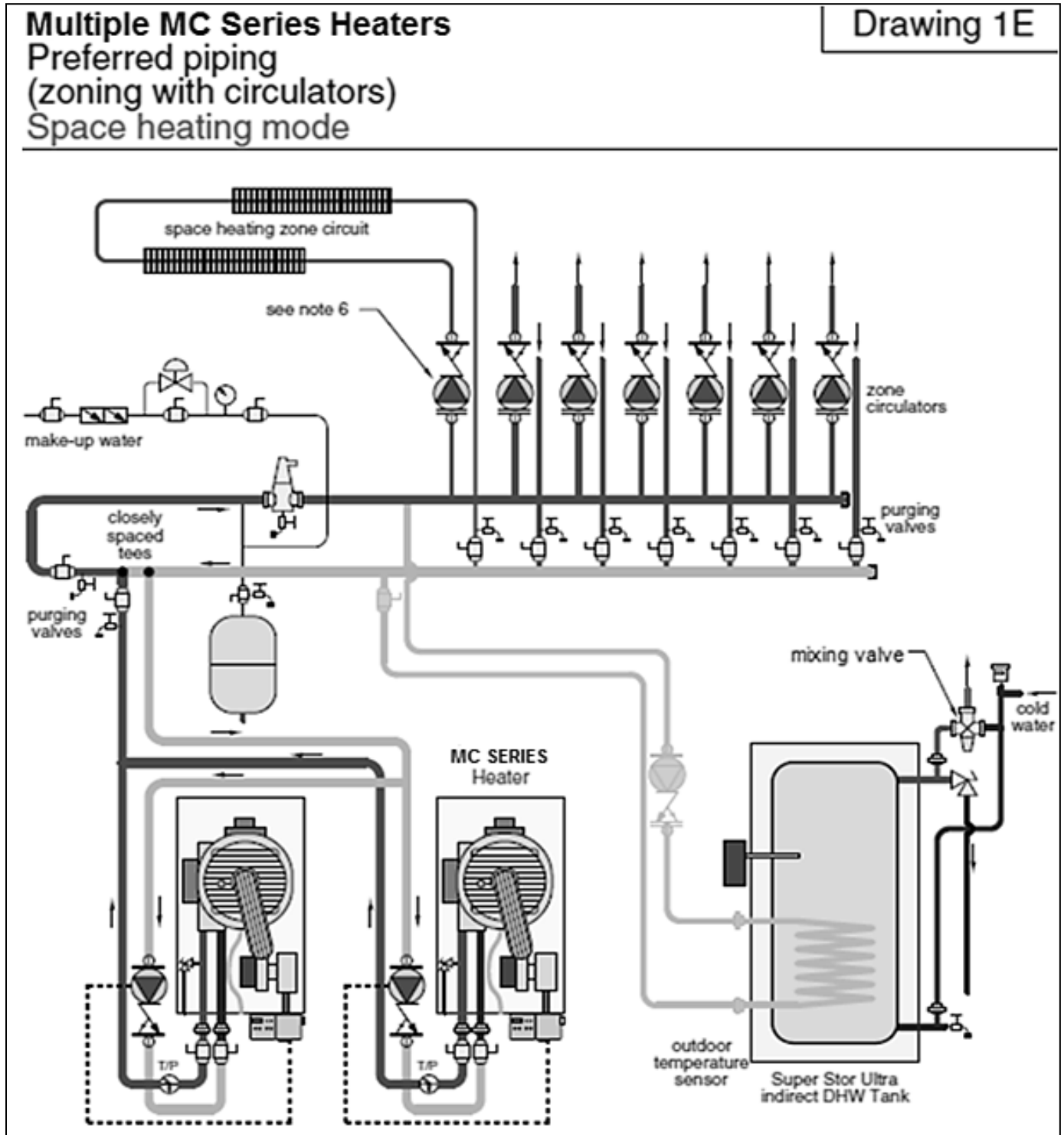

Figure 10

NOTES:

1. This drawing is meant to demonstrate system piping concept only. Installer is responsible for all equipment and detailing required by local codes.
2. All closely spaced tees shall be within 4 pipe diameters center to center spacing.
3. A minimum of 6 pipe diameters of straight pipe shall be installed upstream and downstream of all closely spaced tees.
4. The **minimum** pipe size for connecting an indirect water heater is 1".
5. The **minimum** pipe size for connecting the unit is 1.25".
6. Circulators are shown with isolation flanges. The alternative is standard flanges with full port ball valves. Purge valves can be used with the circulator flanges as an alternative.
7. The anti-scald mixing valve is recommended if the DHW temperature is set above the factory setting of 119°F.
8. Install a minimum of 12 diameters of straight pipe upstream of all circulators.
9. **Winterization:** When winterizing the unit, put a drain valve on both the supply and return between the union and the shut-off connection.

Multiple MC Series Heaters

Preferred piping (zoning with circulators)

Domestic water heating mode

Drawing 1F

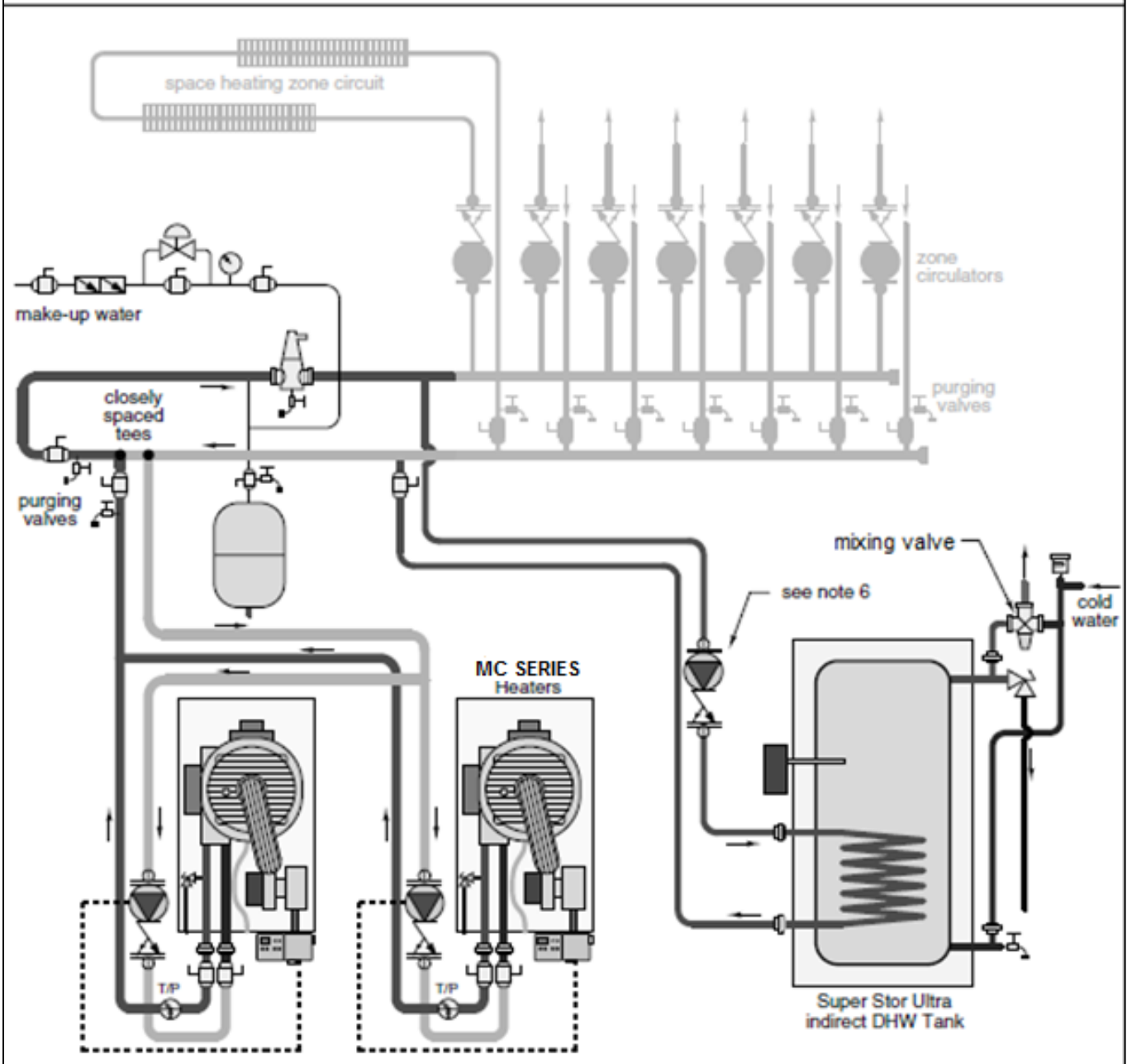

Figure 11

NOTES:

1. This drawing is meant to demonstrate system piping concept only. Installer is responsible for all equipment and detailing required by local codes.
2. All closely spaced tees shall be within 4 pipe diameters center to center spacing.
3. A minimum of 6 pipe diameters of straight pipe shall be installed upstream and downstream of all closely spaced tees.
4. The **minimum** pipe size for connecting an indirect water heater is 1".
5. The **minimum** pipe size for connecting the unit is 1.25".
6. Circulators are shown with isolation flanges. The alternative is standard flanges with full port ball valves. Purge valves can be used with the circulator flanges as an alternative.
7. The anti-scald mixing valve is recommended if the DHW temperature is set above the factory setting of 119°F.
8. Install a minimum of 12 diameters of straight pipe upstream of all circulators.
9. **Winterization:** When winterizing the unit, put a drain valve on both the supply and return between the union and the shut-off connection.

PART 6 – PIPING WITH OPTIONAL VISION 1 SYSTEM (DHW PRIORITY WITH OUTDOOR RESET)

A. VISION 1 SYSTEM PIPING

It is important that the system piping is done correctly when using the Vision 1 System. Follow the piping diagrams 2A through 3G when piping your heater. All general piping practices should still be maintained.

B. ZONING WITH ZONE VALVES USING VISION 1

1. Connect the heater to the system as shown in piping details 2A through 2C.
2. Connect the DHW circulator (P2) directly to the heater as shown in the piping details. The heater circulator (P1) will shut down when there is a DHW demand.

C. ZONING WITH CIRCULATORS USING VISION 1

1. Connect the heater to the system as shown in piping details 3A through 3G.
2. Connect the DHW circulator (P2) directly to the heater as shown in the piping details. The heater circulator (P1) will shut down when there is a DHW demand.

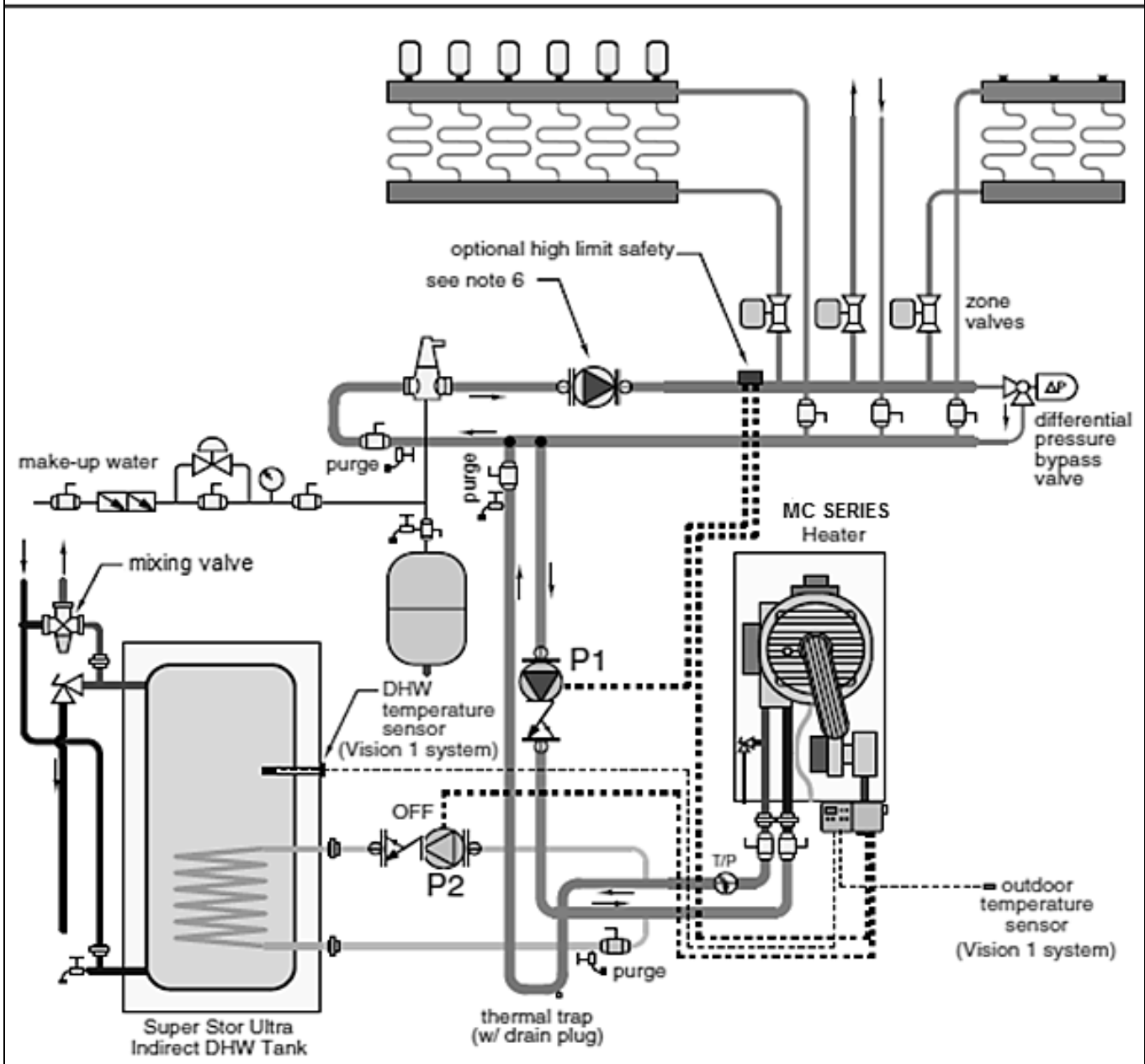
D. PIPING DETAILS WITH THE VISION 1 SYSTEM**MC Series Heater with optional VISION 1 system**
(zoning with valves)
Space heating mode**Drawing 2A****Figure 12****NOTES:**

1. This drawing is meant to demonstrate system piping concept only. Installer is responsible for all equipment and detailing required by local codes.
2. All closely spaced tees shall be within 4 pipe diameters center to center spacing.
3. A minimum of 6 pipe diameters of straight pipe shall be installed upstream and downstream of all closely spaced tees.
4. The **minimum** pipe size for connecting an indirect water heater is 1".
5. The **minimum** pipe size for connecting the unit is 1.25".
6. Circulators are shown with isolation flanges. The alternative is standard flanges with full port ball valves. Purge valves can be used with the circulator flanges as an alternative.
7. Optional Vision 1 system includes temperature sensors for DHW and outdoor air and must be purchased separately.
8. The anti-scald mixing valve is recommended if the DHW temperature is set above the factory setting of 119°F.
9. Install a minimum of 12 diameters of straight pipe upstream of all circulators.
10. **Winterization:** When winterizing the unit, put a drain valve on both the supply and return between the union and the shut-off connection.

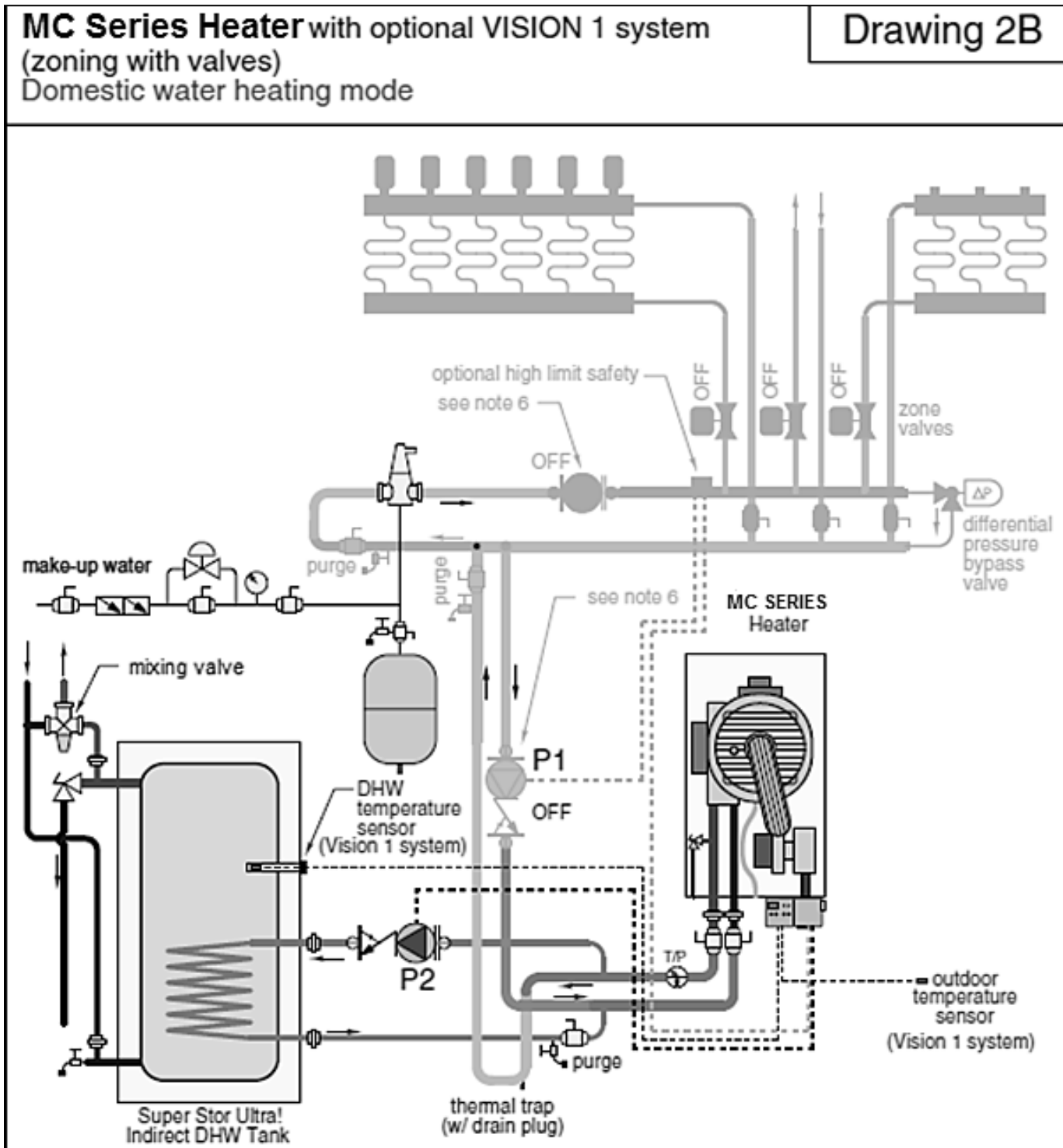

Figure 13

NOTES:

1. This drawing is meant to demonstrate system piping concept only. Installer is responsible for all equipment and detailing required by local codes.
2. All closely spaced tees shall be within 4 pipe diameters center to center spacing.
3. A minimum of 6 pipe diameters of straight pipe shall be installed upstream and downstream of all closely spaced tees.
4. The **minimum** pipe size for connecting an indirect water heater is 1".
5. The **minimum** pipe size for connecting the unit is 1.25".
6. Circulators are shown with isolation flanges. The alternative is standard flanges with full port ball valves. Purge valves can be used with the circulator flanges as an alternative.
7. Optional Vision 1 system includes temperature sensors for DHW and outdoor air and must be purchased separately.
8. The anti-scald mixing valve is recommended if the DHW temperature is set above the factory setting of 119°F.
9. Install a minimum of 12 diameters of straight pipe upstream of all circulators.
10. **Winterization:** When winterizing the unit, put a drain valve on both the supply and return between the union and the shut-off connection.

MC Series Heater with optional VISION 1 system
 (zoning with valves)
 Space heating mode (w/ submixing)

Drawing 2C

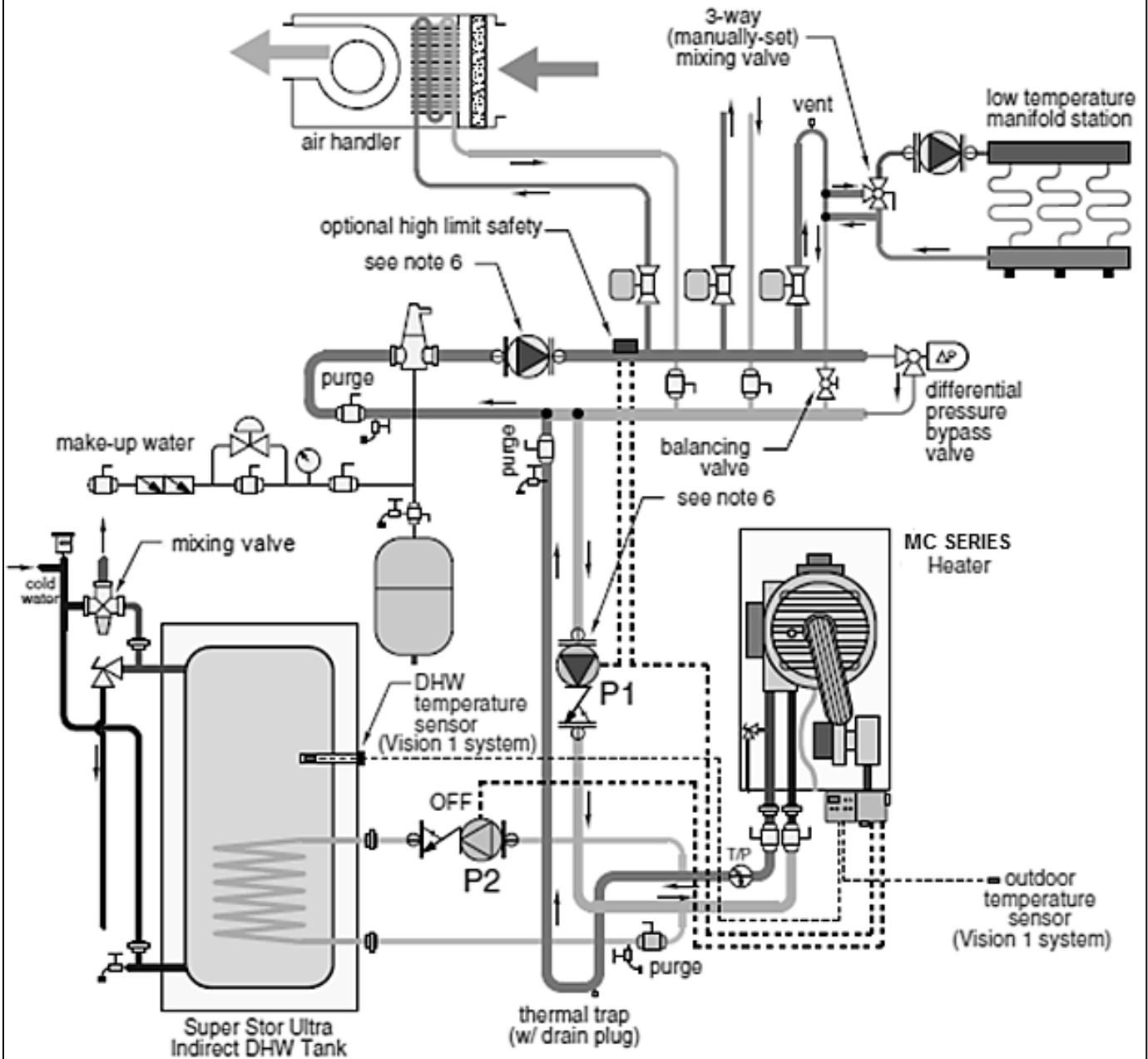

Figure 14

NOTES:

1. This drawing is meant to demonstrate system piping concept only. Installer is responsible for all equipment and detailing required by local codes.
2. All closely spaced tees shall be within 4 pipe diameters center to center spacing.
3. A minimum of 6 pipe diameters of straight pipe shall be installed upstream and downstream of all closely spaced tees.
4. The **minimum** pipe size for connecting an indirect water heater is 1".
5. The **minimum** pipe size for connecting the unit is 1.25".
6. Circulators are shown with isolation flanges. The alternative is standard flanges with full port ball valves. Purge valves can be used with the circulator flanges as an alternative.
7. Optional Vision 1 system includes temperature sensors for DHW and outdoor air and must be purchased separately.
8. The anti-scald mixing valve is recommended if the DHW temperature is set above the factory setting of 119°F.
9. Install a minimum of 12 diameters of straight pipe upstream of all circulators.
10. **Winterization:** When winterizing the unit, put a drain valve on both the supply and return between the union and the shut-off connection.

MC Series Heater with optional VISION 1 system
(zoning with circulators)
Space heating mode

Drawing 3A

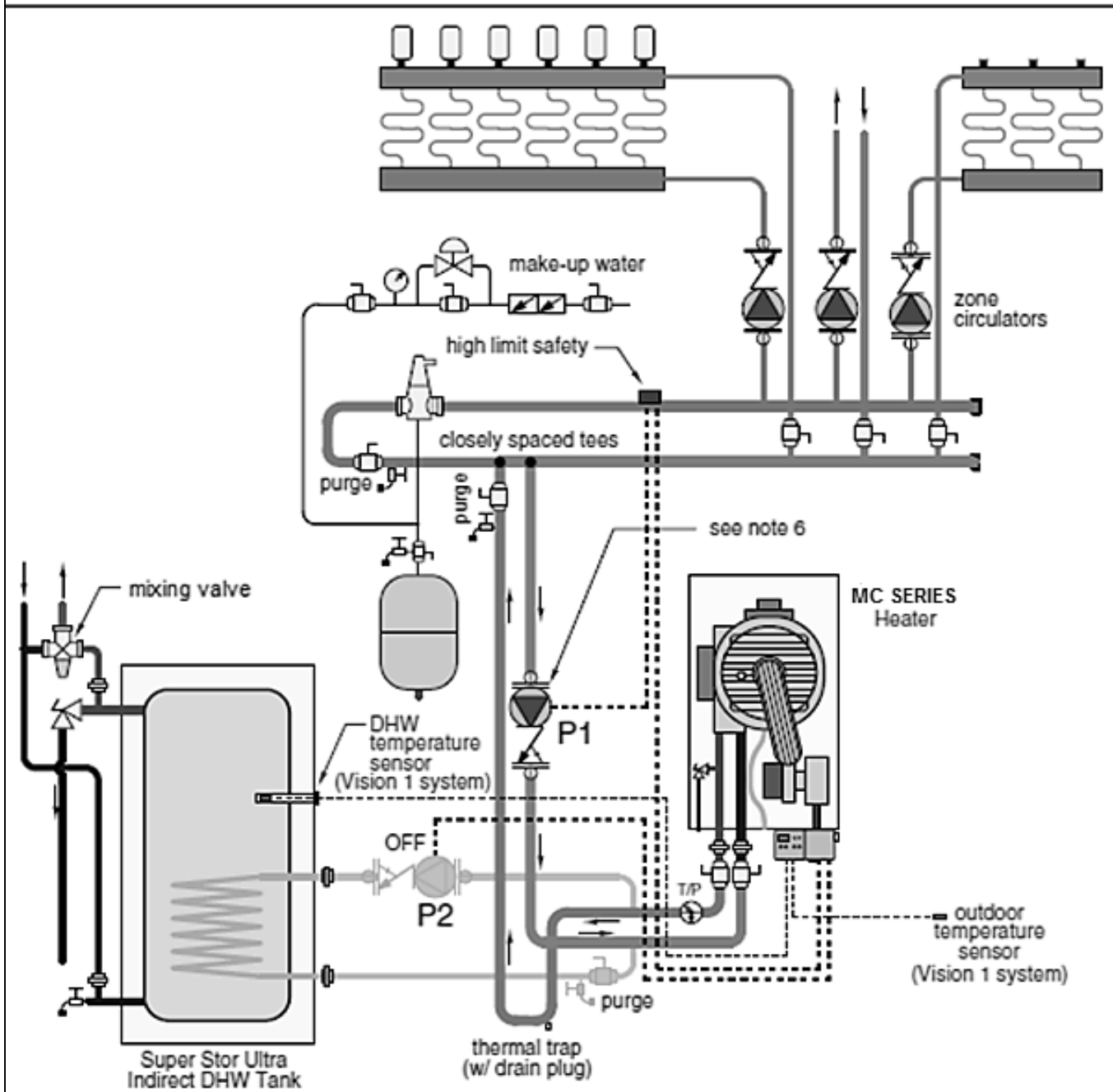

Figure 15

NOTES:

1. This drawing is meant to demonstrate system piping concept only. Installer is responsible for all equipment and detailing required by local codes.
2. All closely spaced tees shall be within 4 pipe diameters center to center spacing.
3. A minimum of 6 pipe diameters of straight pipe shall be installed upstream and downstream of all closely spaced tees.
4. The **minimum** pipe size for connecting an indirect water heater is 1".
5. The **minimum** pipe size for connecting the unit is 1.25".
6. Circulators are shown with isolation flanges. The alternative is standard flanges with full port ball valves. Purge valves can be used with the circulator flanges as an alternative.
7. Optional Vision 1 system includes temperature sensors for DHW and outdoor air and must be purchased separately.
8. The anti-scald mixing valve is recommended if the DHW temperature is set above the factory setting of 119°F.
9. Install a minimum of 12 diameters of straight pipe upstream of all circulators.
10. **Winterization:** When winterizing the unit, put a drain valve on both the supply and return between the union and the shut-off connection.

MC Series Heater with optional VISION 1 system
 (zoning with circulators)
 Domestic water heating mode

Drawing 3B

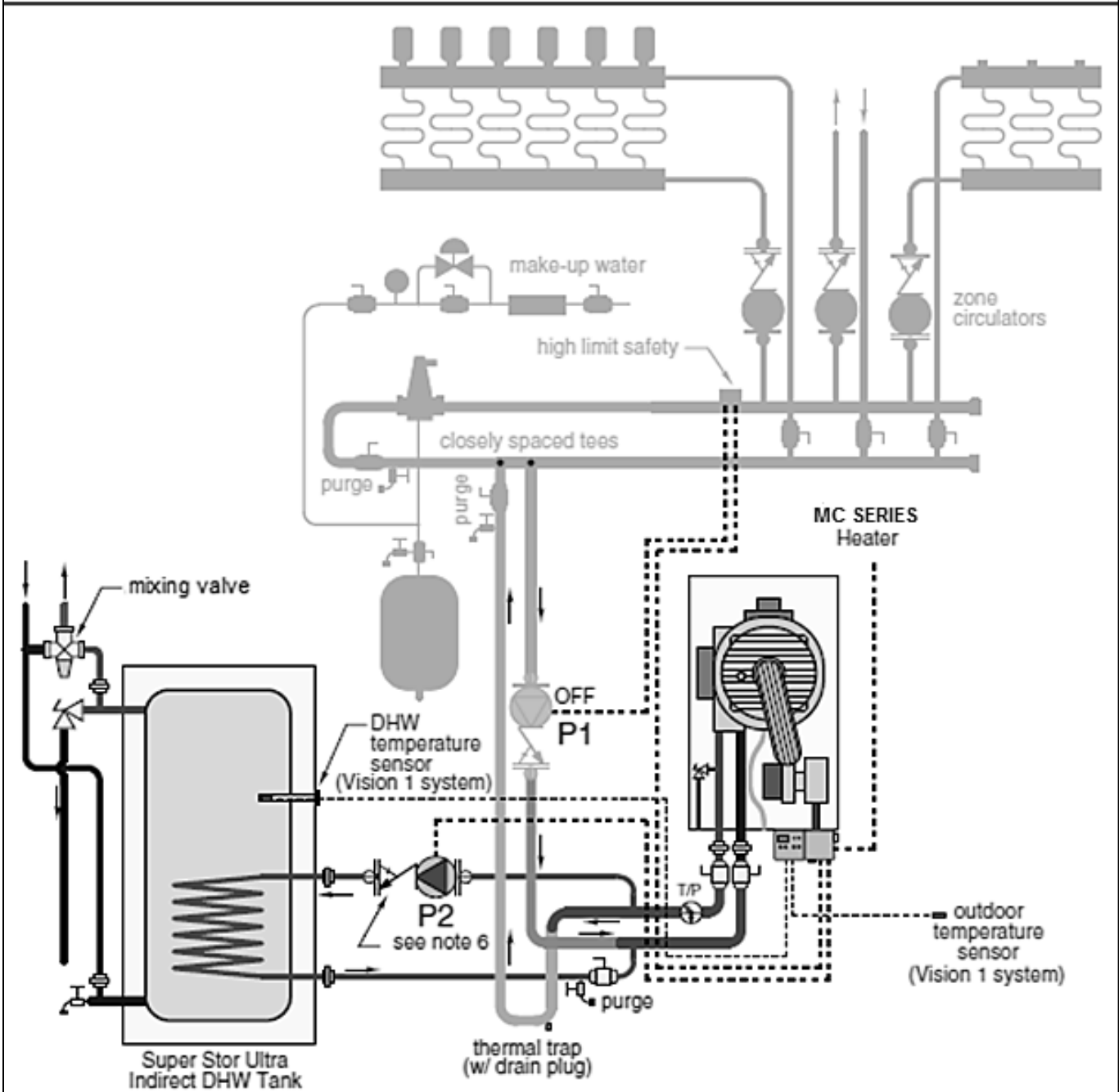

Figure 16

NOTES:

1. This drawing is meant to demonstrate system piping concept only. Installer is responsible for all equipment and detailing required by local codes.
2. All closely spaced tees shall be within 4 pipe diameters center to center spacing.
3. A minimum of 6 pipe diameters of straight pipe shall be installed upstream and downstream of all closely spaced tees.
4. The **minimum** pipe size for connecting an indirect water heater is 1".
5. The **minimum** pipe size for connecting the unit is 1.25".
6. Circulators are shown with isolation flanges. The alternative is standard flanges with full port ball valves. Purge valves can be used with the circulator flanges as an alternative.
7. Optional Vision 1 system includes temperature sensors for DHW and outdoor air and must be purchased separately.
8. The anti-scald mixing valve is recommended if the DHW temperature is set above the factory setting of 119°F.
9. Install a minimum of 12 diameters of straight pipe upstream of all circulators.
10. **Winterization:** When winterizing the unit, put a drain valve on both the supply and return between the union and the shut-off connection.

MC Series Heater with optional VISION 1 system
 (zoning with circulators)
 Space heating mode (w/ submixing)

Drawing 3C

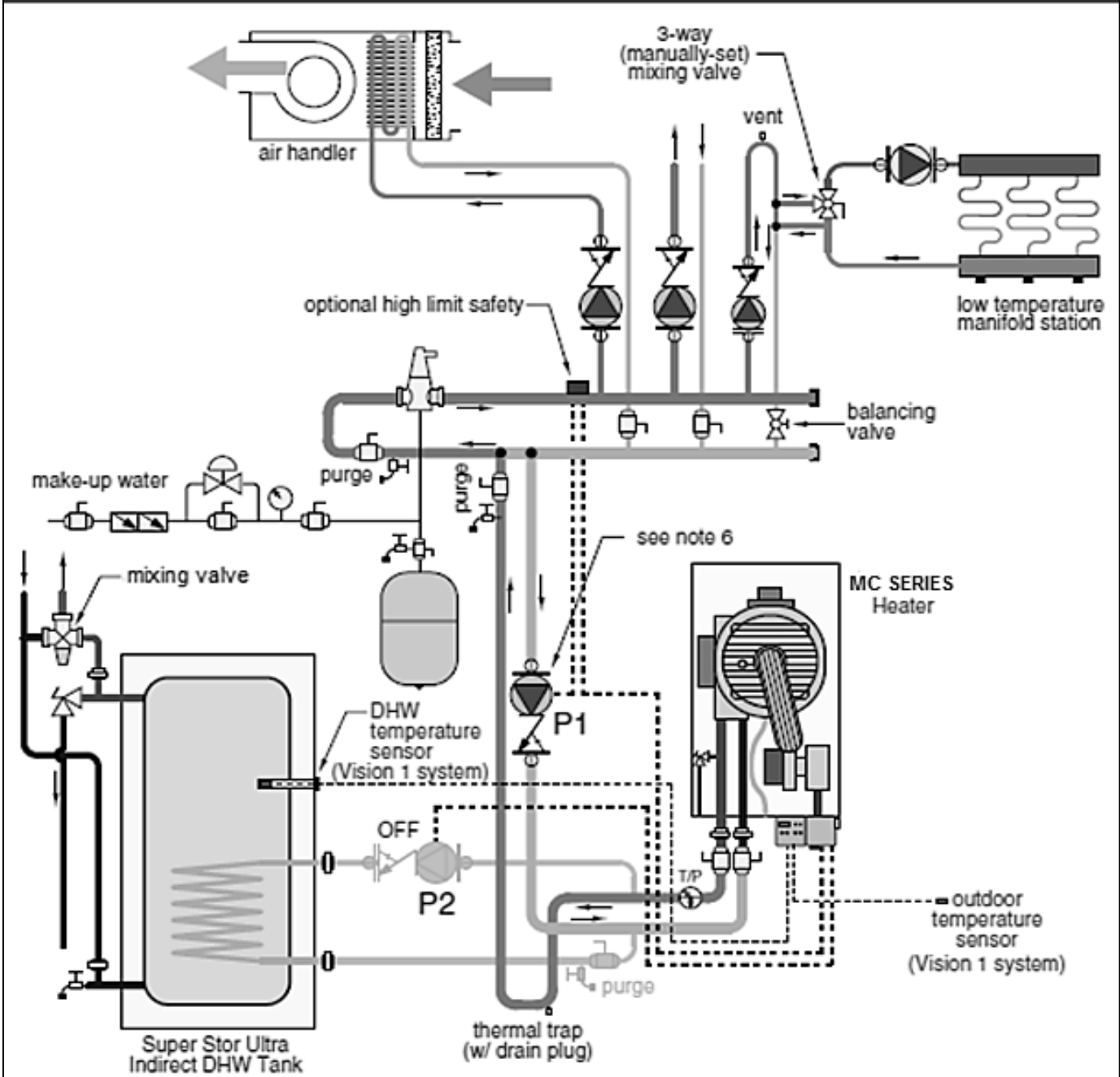

Figure 17

NOTES:

1. This drawing is meant to demonstrate system piping concept only. Installer is responsible for all equipment and detailing required by local codes.
2. All closely spaced tees shall be within 4 pipe diameters center to center spacing.
3. A minimum of 6 pipe diameters of straight pipe shall be installed upstream and downstream of all closely spaced tees.
4. The **minimum** pipe size for connecting an indirect water heater is 1".
5. The **minimum** pipe size for connecting the unit is 1.25".
6. Circulators are shown with isolation flanges. The alternative is standard flanges with full port ball valves. Purge valves can be used with the circulator flanges as an alternative.
7. Optional Vision 1 system includes temperature sensors for DHW and outdoor air and must be purchased separately.
8. The anti-scald mixing valve is recommended if the DHW temperature is set above the factory setting of 119°F.
9. Install a minimum of 12 diameters of straight pipe upstream of all circulators.
10. **Winterization:** When winterizing the unit, put a drain valve on both the supply and return between the union and the shut-off connection.

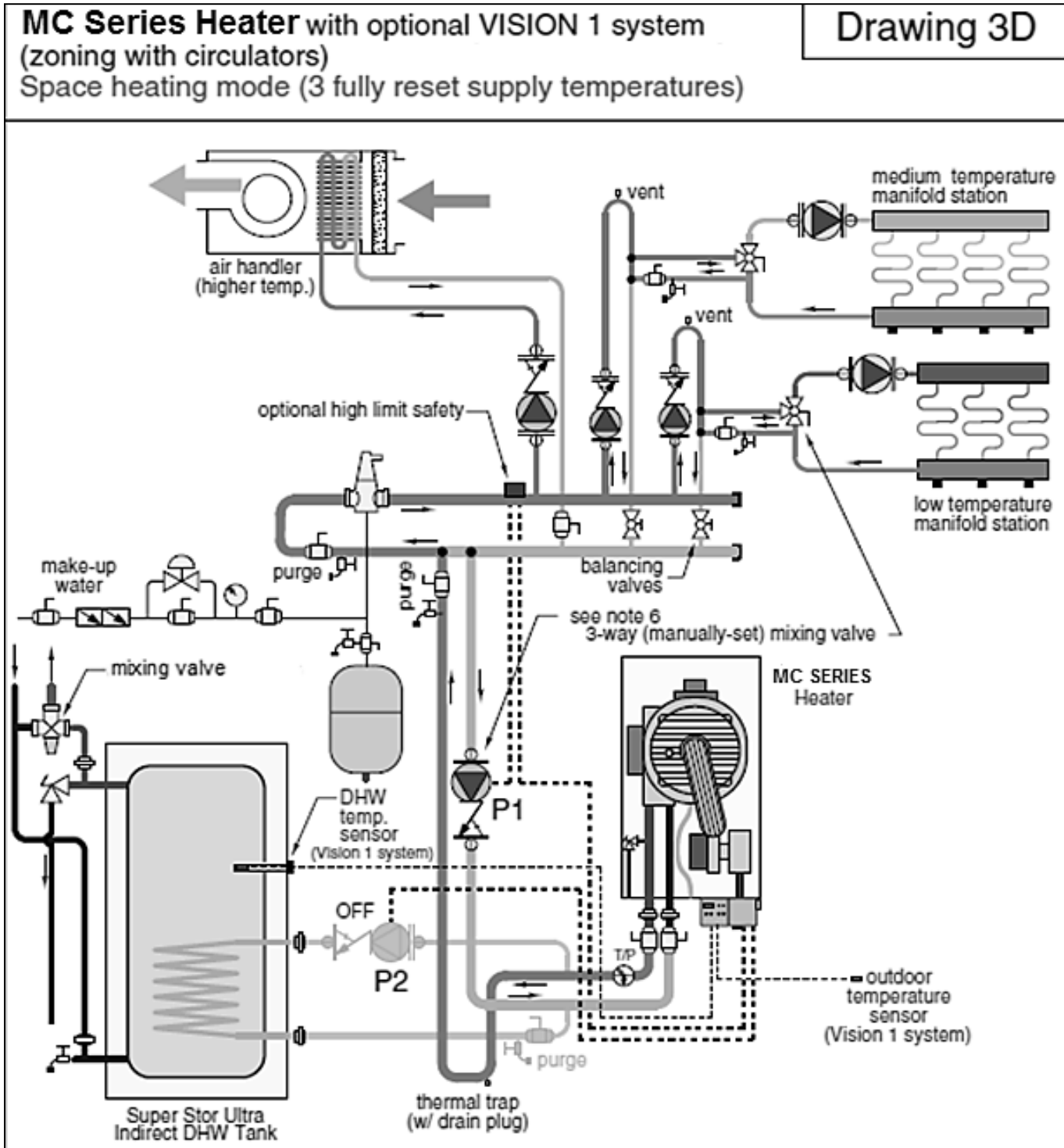

Figure 18

NOTES:

1. This drawing is meant to demonstrate system piping concept only. Installer is responsible for all equipment and detailing required by local codes.
2. All closely spaced tees shall be within 4 pipe diameters center to center spacing.
3. A minimum of 6 pipe diameters of straight pipe shall be installed upstream and downstream of all closely spaced tees.
4. The **minimum** pipe size for connecting an indirect water heater is 1".
5. The **minimum** pipe size for connecting the unit is 1.25".
6. Circulators are shown with isolation flanges. The alternative is standard flanges with full port ball valves. Purge valves can be used with the circulator flanges as an alternative.
7. Optional Vision 1 system includes temperature sensors for DHW and outdoor air and must be purchased separately.
8. The anti-scald mixing valve is recommended if the DHW temperature is set above the factory setting of 119°F.
9. Install a minimum of 12 diameters of straight pipe upstream of all circulators.
10. **Winterization:** When winterizing the unit, put a drain valve on both the supply and return between the union and the shut-off connection.

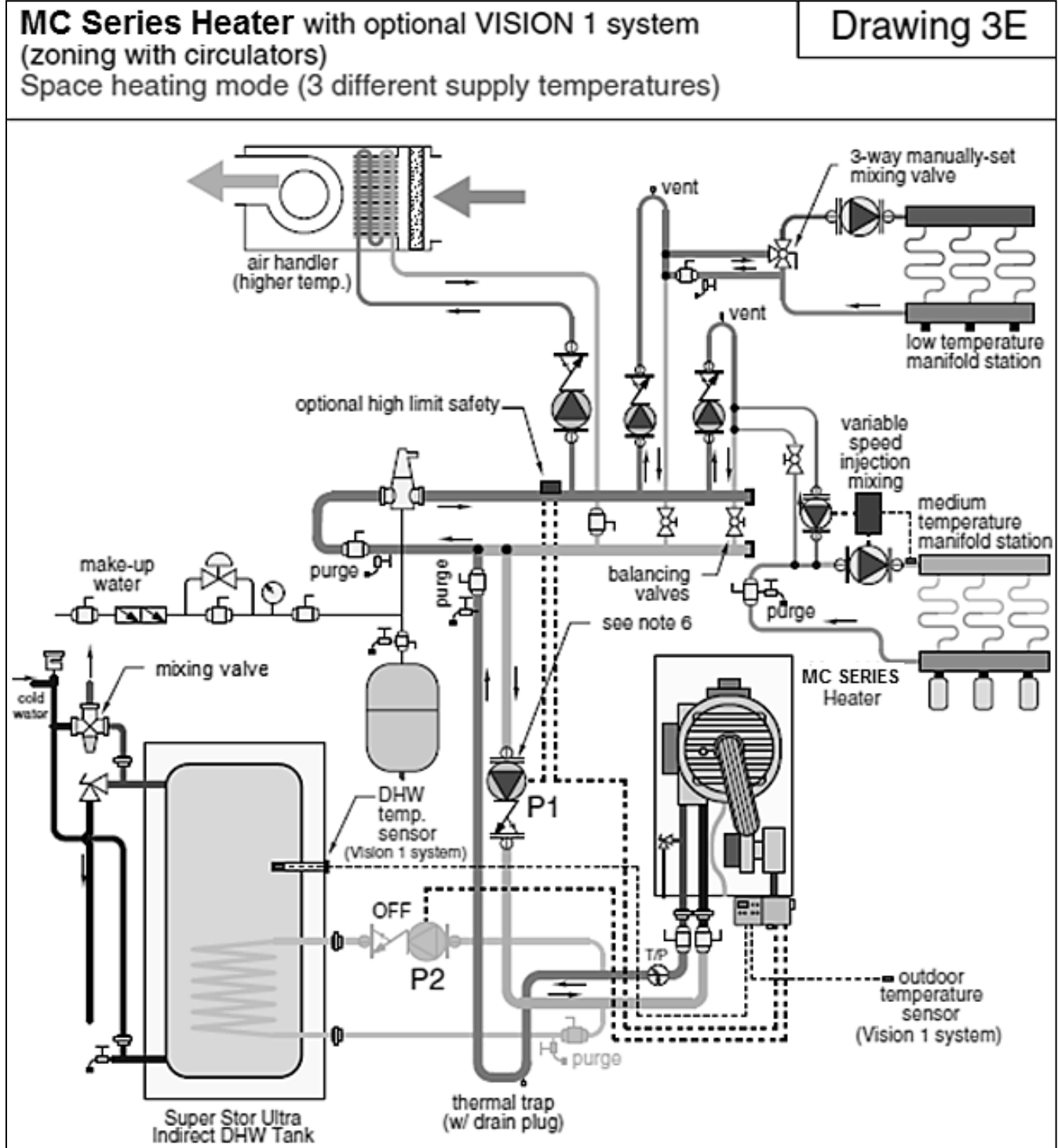

Figure 19 – NOTES:

1. This drawing is meant to demonstrate system piping concept only. Installer is responsible for all equipment and detailing required by local codes.
2. All closely spaced tees shall be within 4 pipe diameters center to center spacing.
3. A minimum of 6 pipe diameters of straight pipe shall be installed upstream and downstream of all closely spaced tees.
4. The **minimum** pipe size for connecting an indirect water heater is 1".
5. The **minimum** pipe size for connecting the unit is 1.25".
6. Circulators are shown with isolation flanges. The alternative is standard flanges with full port ball valves. Purge valves can be used with the circulator flanges as an alternative.
7. Optional Vision 1 system includes temperature sensors for DHW and outdoor air and must be purchased separately.
8. The anti-scald mixing valve is recommended if the DHW temperature is set above the factory setting of 119°F.
9. Install a minimum of 12 diameters of straight pipe upstream of all circulators.
10. **Winterization:** When winterizing the unit, put a drain valve on both the supply and return between the union and the shut-off connection.

MC Series Heater with optional VISION 1 system

Drawing 3F

Multiple high temperature priority loads controlled with zone valves

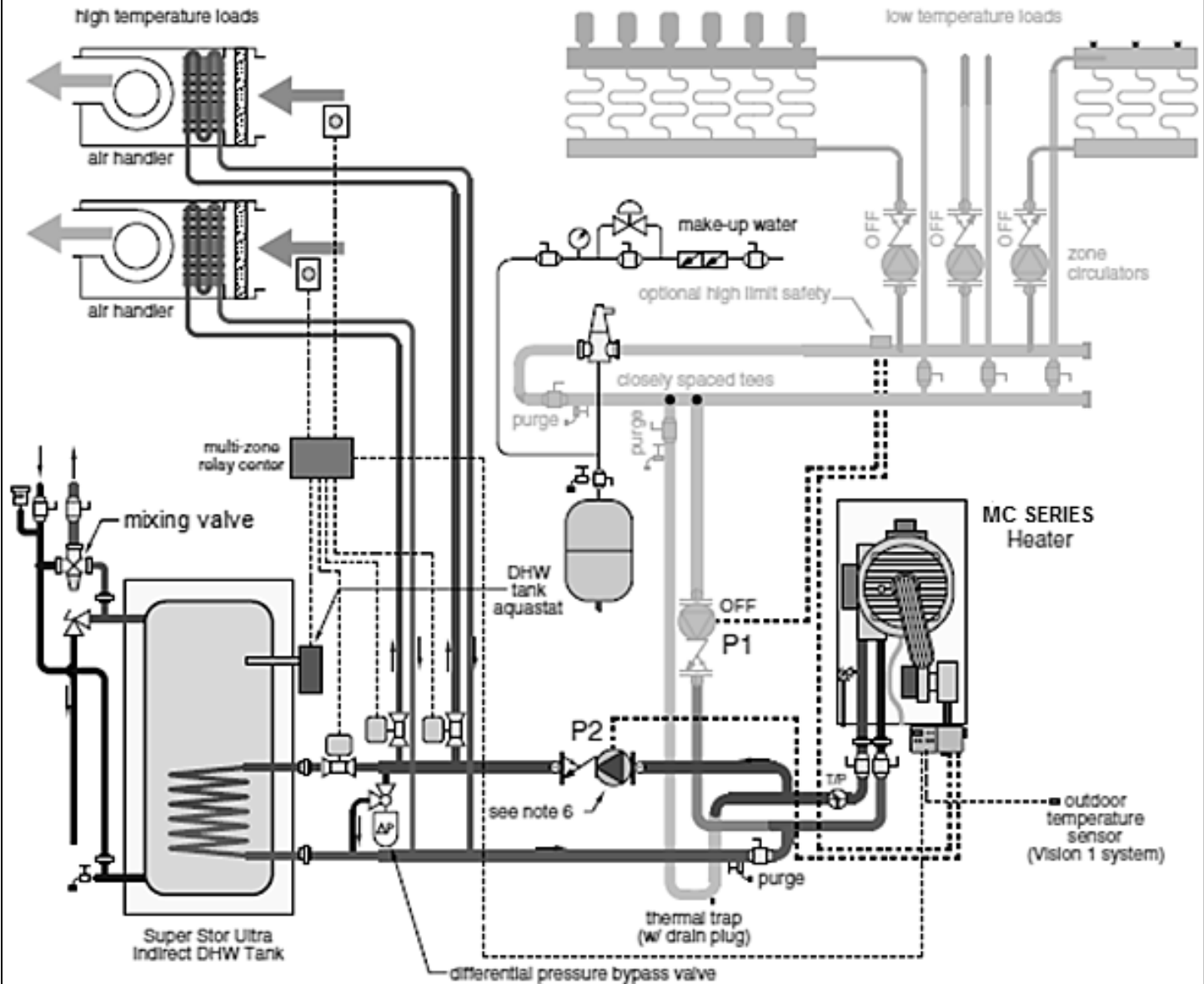

Figure 20

NOTES:

1. This drawing is meant to demonstrate system piping concept only. Installer is responsible for all equipment and detailing required by local codes.
2. All closely spaced tees shall be within 4 pipe diameters center to center spacing.
3. A minimum of 6 pipe diameters of straight pipe shall be installed upstream and downstream of all closely spaced tees.
4. The **minimum** pipe size for connecting an indirect water heater is 1".
5. The **minimum** pipe size for connecting the unit is 1.25".
6. Circulators are shown with isolation flanges. The alternative is standard flanges with full port ball valves. Purge valves can be used with the circulator flanges as an alternative.
7. Optional Vision 1 system includes temperature sensors for DHW and outdoor air and must be purchased separately.
8. The anti-scald mixing valve is recommended if the DHW temperature is set above the factory setting of 119°F.
9. Install a minimum of 12 diameters of straight pipe upstream of all circulators.
10. **Winterization:** When winterizing the unit, put a drain valve on both the supply and return between the union and the shut-off connection.

Drawing 3G

MC Series Heater with optional VISION 1 system
Multiple high temperature priority loads
controlled with zone circulators
Multiple low temperature load controls with zone circulators

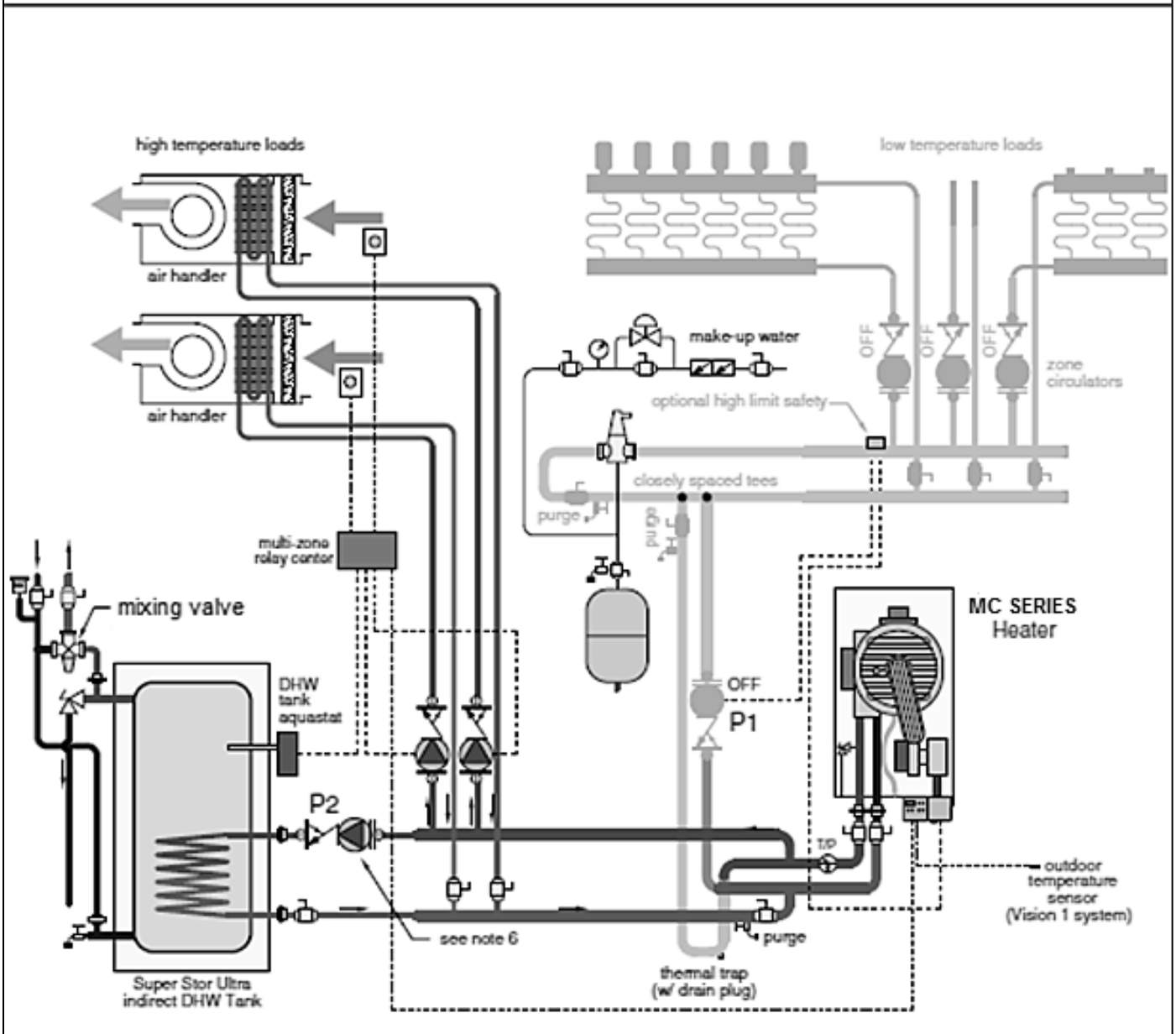

Figure 21

NOTES:

1. This drawing is meant to demonstrate system piping concept only. Installer is responsible for all equipment and detailing required by local codes.
2. All closely spaced tees shall be within 4 pipe diameters center to center spacing.
3. A minimum of 6 pipe diameters of straight pipe shall be installed upstream and downstream of all closely spaced tees.
4. The **minimum** pipe size for connecting an indirect water heater is 1".
5. The **minimum** pipe size for connecting the unit is 1.25".
6. Circulators are shown with isolation flanges. The alternative is standard flanges with full port ball valves. Purge valves can be used with the circulator flanges as an alternative.
7. Optional Vision 1 system includes temperature sensors for DHW and outdoor air and must be purchased separately.
8. The anti-scald mixing valve is recommended if the DHW temperature is set above the factory setting of 119°F.
9. Install a minimum of 12 diameters of straight pipe upstream of all circulators.
10. **Winterization:** When winterizing the unit, put a drain valve on both the supply and return between the union and the shut-off connection.

PART 7 – VENTING, COMBUSTION AIR, AND CONDENSATE REMOVAL

DANGER

The heater must be vented as detailed in this Venting Section. Ensure exhaust vent and intake piping complies with these instructions regarding vent system. Inspect finished exhaust vent and intake piping thoroughly to ensure all joints are well secured, airtight, and comply with all applicable code requirements, as well as with the instructions provided in this manual. Failure to properly install the vent system will result in property damage, severe personal injury, or death.

A. GENERAL

DANGER

This heater is certified as a “Category IV” appliance, and requires a special venting system. The vent system will operate with a positive pressure in the pipe. Exhaust gases must be piped directly outdoors using the vent materials and rules outlined in these instructions. Do not connect vent connectors serving appliances vented by natural draft into any portion of mechanical draft systems operating under positive pressure. Follow the venting instructions below carefully. Failure to do so will result in substantial property damage, severe personal injury, or death.

1. Installation should be made in accordance with the regulations of the Authority Having Jurisdiction, local code authorities, and utility companies which pertain to this type of water heating equipment.
2. Install the venting system in accordance with these instructions and with the National Fuel Gas Code, ANSI Z223.1/NFPA 54, CAN/CGA B149, and/or applicable provisions of local building codes.
3. This water heater must be vented with materials, components, and systems listed and approved for Category IV appliances.

DANGER

Exhaust vent and intake pipes are to be piped separately. This heater cannot share a common exhaust or intake with multiple appliances. Failure to follow this instruction will result in substantial property damage, severe personal injury, or death.

NOTE: To avoid contamination often contained in indoor air, it is best to pipe all intake combustion air directly to the outdoors.

NOTE: If exhaust vent pipe system passes through an unheated space, such as an alcove or attic, the space must be heated or the pipe must be insulated. The insulation must have an R value sufficient to prevent freezing of the condensate.

WARNING

Improper seating of vent pipe gaskets can cause eventual gasket failure and exhaust gas leakage. Ensure the exhaust vent pipe is properly beveled and seated before insertion into the flue adapter. Failure to do so could result in property damage, severe personal injury, or death.

DANGER

Due to the extreme flammability of most glues, cements, solvents, and primers used to join plastic exhaust vent and intake pipes, explosive solvent vapors must be cleared from all vent piping before start-up. Avoid using excess cement or primer, as this may pool in the vent pipes. Vent assemblies should be allowed to cure for a period of at least 8 hours before powering a connected appliance. Failure to follow these instructions will result in substantial property damage, severe personal injury, or death. It is the installers' responsibility to understand the hazards associated with explosive solvents and take the necessary precautions to avoid these risks.

B. APPROVED MATERIALS FOR EXHAUST VENT AND INTAKE PIPE

APPROVED EXHAUST VENT AND INTAKE PIPE MATERIAL			
Item	Material	Standards for Installation in:	
		United States	Canada
Exhaust vent or Intake pipe and fittings	PVC schedule 40/80	ANSI/ASTM D1785	PP, CPVC, and PVC venting must be ULC-S636 Certified. IPEX is an approved manufacturer in Canada, supplying vent material listed to ULC-S636.
	PVC-DWV	ANSI/ASTM D2665	
	CPVC schedule 40/80	ANSI/ASTM F441	
	Polypropylene	UL-1738	Certified for Category IV and direct vent appliance venting
	Stainless Steel AL29-4C	Certified for Category IV and direct vent appliance venting	
Pipe cement/primer	PVC	ANSI/ASTM D2564	IPEX System 636 Cements & Primers
	CPVC	ANSI/ASTM F493	

 DANGER

- The exhaust and intake components installed with this heater must be used for near heater piping BEFORE transitioning to the approved materials listed above. DO NOT REMOVE these installed components. Doing so WILL VOID appliance warranty.
 - PVC/CPVC pipe and fittings of the same diameter are considered interchangeable.
 - Do NOT use Foam Core Pipe in any portion of the exhaust piping from this heater.
 - DO NOT connect PVC/CPVC to PP without an approved vent connector.
 - When installing AL29-4C vent piping, install a PVC-to-stainless adapter at the heater vent connection, and at the termination when using an HTP PVC termination kit. DO NOT mix AL-29-4C piping from different manufacturers unless using adapters specifically designed for the purpose by the manufacturer.
- Failure to follow these directions will result in substantial property damage, severe personal injury, or death.

Table 4 – Approved Materials for Exhaust Vent and Intake Pipe** WARNING**

DO NOT mix components from different venting systems. The vent system could fail, causing leakage of flue products into the living space. Use only the approved pipe and fitting materials, and primer and cement specifically designed for the material used, as listed in Table 4. Failure to do so could result in property damage, severe personal injury, or death.

 WARNING

Exhaust vent adaptors are not designed as load-bearing devices, and must not be used to support exhaust vent piping. All vent pipes must be glued, properly supported, and the exhaust must be pitched a minimum of ¼" per foot back to the heater to allow drainage of condensate. Failure to properly support vent piping and follow the information in this statement could result in product damage, severe personal injury, or death.

NOTE: The use of double-wall vent or insulated material for the combustion air inlet pipe is recommended in cold climates to prevent the condensation of airborne moisture in the incoming combustion air.

CAUTION

High heat sources (sources generating heat 100°F / 37°C or greater, such as stove pipes, space heaters, etc.) may damage plastic components of the boiler as well as plastic vent pipe materials. Such damages ARE NOT covered by warranty. It is recommended to keep a minimum clearance of 8" from high heat sources. Observe heat source manufacturer instructions, as well as local, state, provincial, and national codes, laws, regulations and ordinances when installing this boiler and related components near high heat sources.

C. REQUIREMENTS FOR INSTALLATION IN CANADA

1. Installations must be made with a vent pipe system certified to ULC-S636. IPEX is an approved vent manufacturer in Canada supplying vent material listed to ULC-S636. Additionally you may use AL29-4C stainless steel venting to comply with Canadian requirements.

2. The first three (3) feet of vent pipe from the heater flue outlet must be readily accessible for visual inspection.

3. The components of the certified vent system must not be interchanged with other vent systems or unlisted pipe / fittings.

Cellular foam core piping may be used on air inlet piping **only**.

⚠ DANGER

You must not use “B” vent in an exhaust application. “B” vent is for intake applications **ONLY**. Using “B” vent in an exhaust application will result in serious injury or death.

D. EXHAUST VENT AND INTAKE PIPE LOCATION

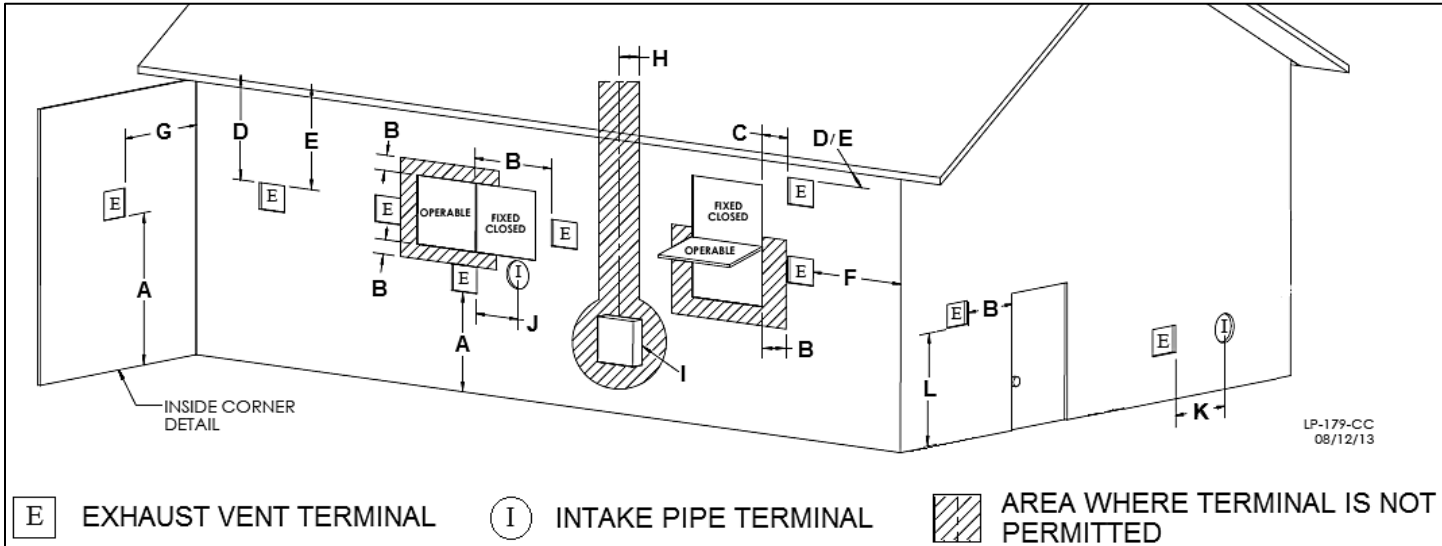

Figure 22 – ANSI Z223.1 / NFPA 54 for US and CAN/CSA B149.1 for Canada – Exit Terminals for Direct-Vent Venting Systems

DETERMINE EXHAUST VENT AND INTAKE PIPE LOCATION – FIGURE 22 NOTES:

- A.** Provide a minimum of 1 foot clearance from the bottom of the exhaust vent and intake pipe above the expected snow accumulation level. Snow removal may be necessary to maintain clearance.
 - B.** Provide a minimum of 1 foot distance from exhaust vent termination to any door, operable window, or gravity intake into any building.
 - C.** Provide a minimum of 1 foot distance from exhaust vent termination to any permanently closed door or window.
 - D.** Provide a minimum of 4 feet vertical clearance from the exhaust vent to all roof overhangs.
 - E.** Locating exhaust vent termination near roof overhangs will result in the formation of icicles in freezing weather, and could result in blockage of the exhaust vent. To prevent icicles from forming, maintain 4 feet vertical clearance from the exhaust vent to all roof overhangs.
 - F.** Provide 4 feet clearance from the outside corner of vertical walls, chimneys, etc., as well as horizontal corners created by roof overhangs.
 - G.** Provide 6 feet clearance from the inside corner of vertical walls, chimneys, etc., as well as horizontal corners created by roof overhangs.
 - H.** Provide 4 feet clearance from center line within a height of 15 feet above electrical meters, gas meters, gas regulators, relief equipment, exhaust fans and inlets.
 - I.** Provide 4 feet horizontal clearance from electrical meters, gas meters, gas regulators, relief equipment, exhaust fans and inlets. In no case shall the exit terminal be above or below the aforementioned equipment unless the 4 foot horizontal distance is maintained.
 - J.** This water heater vent system shall terminate at least 3 feet (0.9 m) above any forced air intake located within 10 ft (3 m).
- NOTE:** This does not apply to the combustion air intake of a direct-vent appliance.
- K.** When venting with a two pipe system, maximum distance between exhaust vent and intake pipe is 6 feet (1.8 m). Minimum distance between exhaust vent and intake pipe on single direct vented appliance is 10” (0.255 m) center-to-center. Minimum distance between exhaust vents and intake pipes on multiple water heaters is 10” (0.255 m) center-to-center.
 - L.** When adjacent to a public walkway, locate exit terminal at least 7 feet above grade.

In addition:

- Total length of vent piping shall not exceed the limits specified in this manual.
- The vent piping for this direct vented appliance is approved for zero clearance to combustible construction.
- The flue products coming from the exhaust vent will create a large plume when the boiler is in operation. Avoid venting in areas that will affect neighboring buildings or be considered objectionable.
- DO NOT locate exhaust vent or intake pipe in a parking area where machinery may damage the pipe.
- DO NOT locate the exhaust vent or intake pipe terminals under a porch, balcony, or veranda.

⚠ WARNING

Breathing Hazard - Carbon Monoxide Gas

- Do not operate heater if flood damaged.
- Install vent system in accordance with local codes and manufacturers installation instructions.
- Do not obstruct heater air intake or exhaust. Support all vent piping per manufacturers installation instructions.
- Do not place chemical vapor emitting products near unit.
- According to NFPA 720, carbon monoxide detectors should be installed outside each sleeping area.
- Never operate the heater unless it is vented to the outdoors.
- Analyze the entire vent system to make sure that condensate will not become trapped in a section of vent pipe and therefore reduce the open cross sectional area of the vent.

Breathing carbon monoxide can cause brain damage or death. Always read and understand instruction manual.

LP-304 4/28/09

- Avoid terminating exhaust vents near shrubs, air conditioners, or other objects that will obstruct the exhaust stream.
- DO NOT vent over a public walkway. Condensate could drip or freeze and create a nuisance or hazard.

NOTE: Due to potential moisture build-up, sidewall venting may not be the preferred venting option. Carefully consider venting installation and location to save time and cost.

WARNING

The building owner is responsible for keeping the exhaust and intake terminations free of snow, ice, or other potential blockages, as well as scheduling routine maintenance. Failure to keep the vent piping terminations clear and properly maintain the heater could result in property damage, severe personal injury, or death.

WARNING

For each floor containing bedroom(s), a carbon monoxide detector and alarm shall be placed in the living area outside the bedrooms, as well as in the room that houses the heater. Detectors and alarms shall comply with NFPA 720 (latest edition). Failure to comply with requirements for detectors and alarms could result in property damage, severe personal injury, or death.

DETERMINE THE LOCATION OF CONDENSATE PIPING

This is a high efficiency heater, and therefore produces condensate: a by-product of the combustion process. A condensate collection system with an internal float switch monitors condensate level to prevent it from backing up into the combustion system. There is a 3/4" socket connection provided to connect the outlet of the collection system to a drain or condensate pump (kit p/n 554200 available from HTP). If the heater condensate outlet is lower than the drain, you must use a condensate removal pump.

NOTE: The installer should fill the condensate trap with tap water prior to operating the heater.

NOTE: The use of 1/2" PVC or CPVC pipe are acceptable materials for condensate piping. Steel, brass, copper or other materials will be subject to corrosion or deterioration. However, use materials approved by the authority having jurisdiction.

In the absence of other authority, PVC and CPVC pipe must comply with ASTM D1785 or D2845. Cement and primer must comply with ASME D2564 or F493. For Canada, use CSA or ULC certified PVC or CPVC pipe, fittings, and cement. If pipe is used, deburr and chamfer pipe to allow proper mating to the drainage assembly.

NOTE: To allow for proper drainage on long horizontal runs, a second line vent may be required and tubing size may need to increase to 1". Support of the condensate line may be necessary to avoid blockage of the condensate flow. Failure to add a second vacuum break could result in condensate backup, improper heater operation, and nuisance shutdowns.

DANGER

The condensate trap assembly **MUST BE PROPERLY INSTALLED** when operating the heater. Operating the heater without the condensate trap assembly will cause flue gases to leak and result in serious personal injury or death.

NOTE: Check with your local gas company to determine if combustion condensate disposal is permitted in your area. In the state of Massachusetts, condensate must be neutralized before entering a drain.

CONDENSATE NEUTRALIZATION

Condensate from the heater is slightly acidic with a pH of 3.2 - 4.5. To avoid long term damage to the drainage system and to meet local code requirements, HTP recommends neutralizing the condensate with a Condensate Neutralizer Kit (p/n N1100). The neutralizer kit connects to the drain system and contains limestone chips that neutralize the pH level of the water vapor. The neutralizer kit should be checked annually and the limestone chips replenished if necessary. When replacing the limestone chips, take care to ensure chips are no smaller than 1/2" to avoid blockage in condensate piping (for piping details, refer to condensate neutralizer installation instruction.)

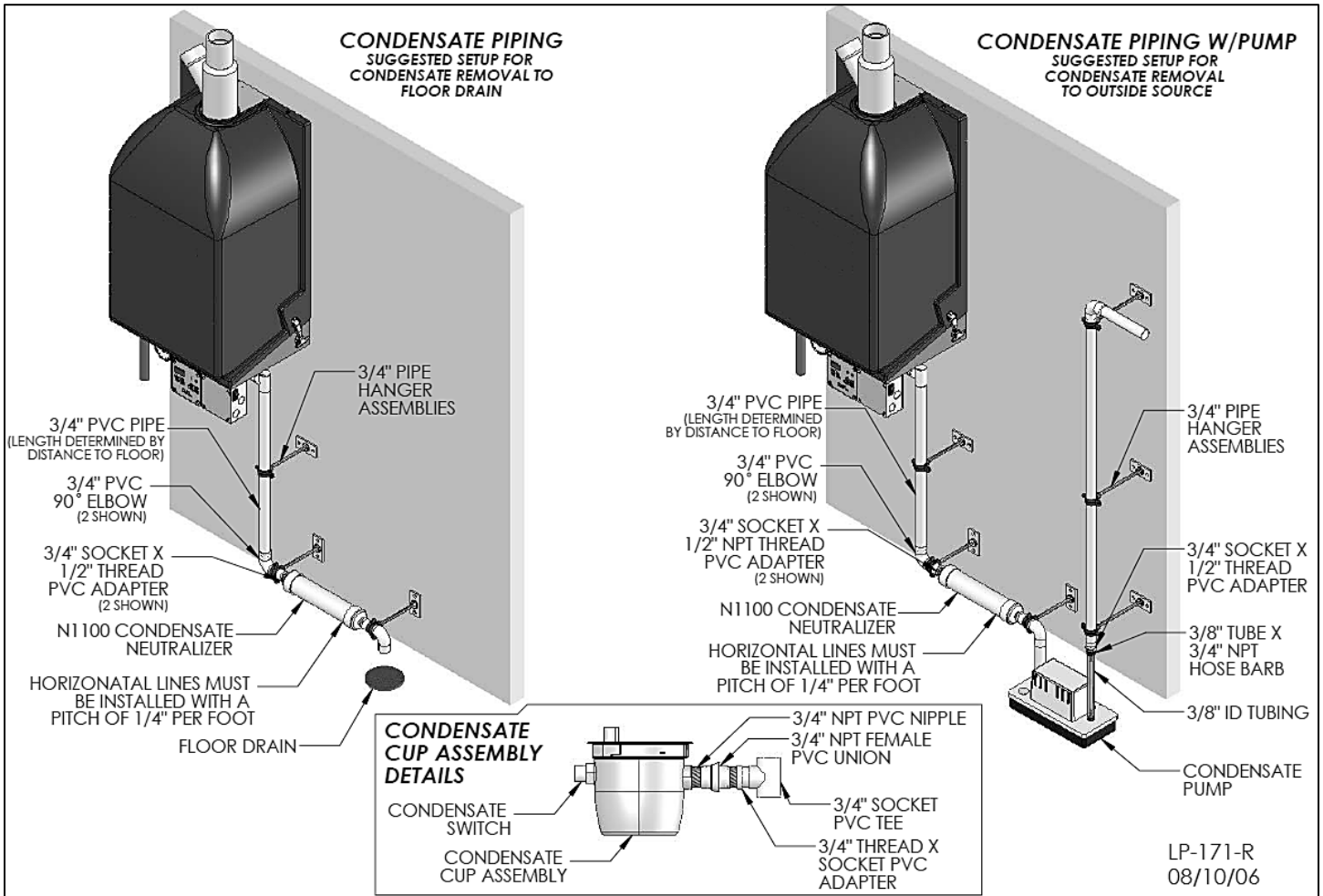

Figure 23 – Condensate Details

NOTES:

1. Condensate line must be pitched at least 1/4" per foot to properly drain. If this cannot be done, or a very long length of condensate hose is used, you must increase the condensate line to a minimum of 1" ID and place a tee in the line after the condensate neutralizer to properly reduce vacuum lock in the drain line.
2. Plastic pipe should be the only material used for the condensate line. Steel, brass, copper, or other materials will be subject to corrosion or deterioration.
3. NEVER install condensate lines outside. It is very important that the condensate line is not exposed to freezing temperatures or any type of blockage. Damages due to frozen or blocked condensate lines ARE NOT covered by warranty.
4. Support of the condensate line may be necessary to avoid blockage of the condensate flow.

CAUTION
If using a condensate pump, select one approved for use with condensing heaters and furnaces. The pump should have an overflow switch to prevent property damage from condensate spillage.
CAUTION
It is very important that the condensate piping be no smaller than 3/4". To prevent sagging and maintain pitch, condensate piping should be supported with pipe supports, and pitched 1/4" per foot to allow for proper drainage.
CAUTION
The condensate line must remain unobstructed, allowing free flow of condensate. If condensate freezes in the line, or if line is obstructed in any other manner, condensate can exit from the tee, resulting in potential water damage to property.

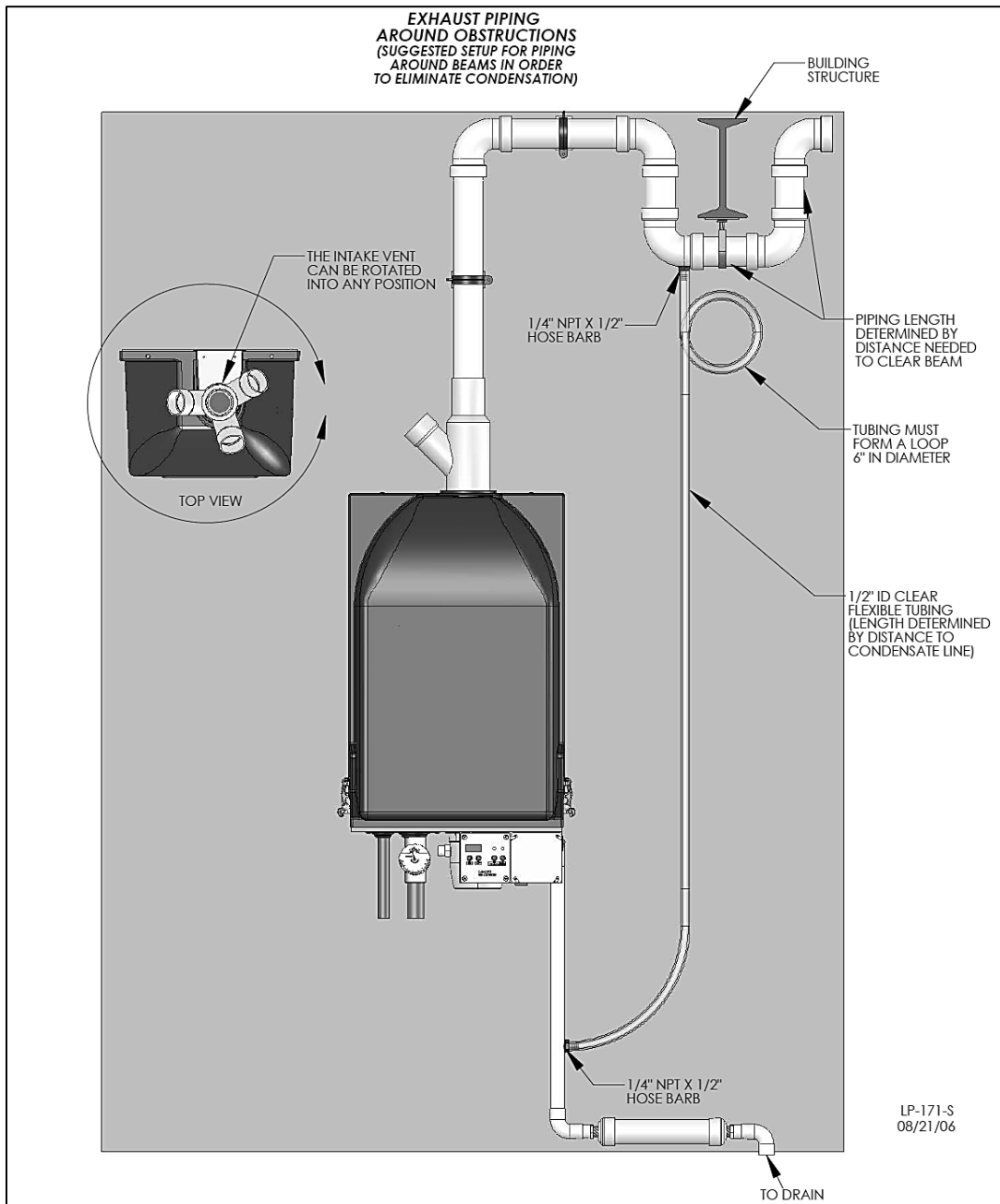

Figure 24 – Piping Exhaust around Obstructions – Suggested Condensate Removal

E. ROTATING THE FLUE ADAPTER

The flue adapter on the top of the heater can be rotated 180 degrees to position the air inlet in the optimum location for most venting and air inlet needs. The flue adapter **MUST** be positioned before the exhaust vent is connected to the adapter.

NOTE: Once the exhaust vent is glued to the flue adapter it can no longer be moved.

NOTE: DO NOT glue optional polypropylene vent system.

To rotate the flue adapter:

1. Remove the black heater cover.
2. Inspect the area where the white flue adapter mates to the black plastic heat exchanger. You will notice two red wires and a plastic hose connected to the flue adapter. These will limit the rotation range of the flue adapter.
3. Grasp the entire white PVC flue adapter and rotate it in the direction that will cause the least strain on the hose and red wires until the air inlet is in the desired orientation. After rotation is complete, push downward on the flue adapter to be sure it is completely seated in the black plastic module.

4. Check again to make sure the red wires and clear plastic hose connected to the flue adapter are properly connected and routed.

F. EXHAUST VENT AND INTAKE PIPE SIZING

1. The exhaust vent and intake pipe size is 2" or greater.
2. The total equivalent length of exhaust vent and intake pipe should **not exceed 85'** for 2" and 125' for 3".
 - a. The equivalent length of elbows, tees, and other fittings are listed in the Friction Loss Table below:

FRICTION LOSS EQUIVALENT IN PIPING AND FITTINGS		
FITTINGS OR PIPING	EQUIVALENT FEET	
	2"	3"
90 DEGREE ELBOW*	5'	5'
45 DEGREE ELBOW	3'	3'
COUPLING	0'	0'
AIR INLET TEE	0'	0'
STRAIGHT PIPE	1'	1'
CONCENTRIC VENT KIT	3'	3'
V500 2' VENT KIT	1'	N/A
V1000 3' VENT KIT	N/A	1'

Table 5 - *Friction loss for long radius elbow is 1 foot less. NOTE: Consult Polypropylene venting instructions for friction loss and pressure drop equivalents.

b. For example: If the exhaust vent has two 90° elbows and 10 feet of PVC pipe we will calculate:
 Exhaust Vent Equivalent Length = (2 x 5) + 10 = 20 feet.

Further, if the intake pipe has two 90° elbows, one 45° elbow and 10 feet of PVC pipe, the following calculation applies:
 Intake Pipe Equivalent Length = (2 x 5) + 3 + 10 = 23 feet.

Finally, if a concentric vent kit is used we find:
 Total Equivalent Length = 20 + 23 + 3 = 46 feet.
 Therefore, the total equivalent length is 46 feet which is well below the maximum of 85 feet.

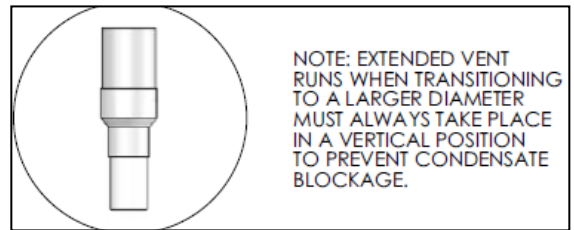

Figure 25 – Upsizing Vent Diameter

- c. The exhaust vent and intake pipe are intended to penetrate the same wall or roof of the building.
- d. Effort should be made to keep a minimum difference in equivalent length between the exhaust vent and intake pipe.

3. The minimum total equivalent length is 32 equivalent feet.

G. LONGER VENT RUNS

The maximum total equivalent length can be extended by increasing the diameter of both exhaust vent and intake pipe equally. However, the transitions should begin a minimum of 15 equivalent feet from the heater.

- a. Transitions should always be made in vertical sections of pipe to prevent the condensate from pooling in the vent pipe.
- b. Use a 3" x 2" reducing coupling to transition from the 2" connections to a 3" vent.
- c. The maximum equivalent length for the increased diameter vent pipes is 125 feet.
- d. If the transition occurs at a distance greater than 15 equivalent feet from the heater, the maximum equivalent length will be reduced. See Table 6. The standard vent pipe is 2".

TRANSITION POINT (FT. FROM HEATER)	TEL OF STANDARD 2" VENT PIPE (FT.)	TEL OF OVERSIZED 2", 3", OR 4" VENT PIPE (FT.)	MAXIMUM TEL OF ALL VENT PIPE (FT.)
15	30	95	125
20	40	77-1/2	117-1/2
25	50	60-1/2	110-1/2
30	60	43	103
35	70	26	96
40	80	8-1/2	88-1/2
NONE	85	0	85

Table 6

H. EXHAUST VENT AND INTAKE PIPE INSTALLATION

1. The 2" exhaust vent connection is located on the top, right side of the unit, and the intake is on the top left side. Use only solid PVC or CPVC pipe, AL29-4C Stainless Steel, or a Polypropylene vent system approved for use with Category IV appliances. FOAM CORE PIPING IS NOT APPROVED.

⚠ WARNING

All joints of positive pressure vent systems must be sealed completely to prevent leakage of flue products into living space.

2. Remove all burrs and debris from joints and fittings.
3. When using PVC or CPVC pipe, all joints must be properly cleaned, primed, and cemented. Use only cement and primer approved for use with the pipe material. Cement must conform to ASTM D2564 for PVC and ASTM F493 for CPVC pipe. **NOTE: DO NOT CEMENT POLYPROPYLENE PIPE.**
4. Ensure the vent is located where it will not be exposed to prevailing winds.
5. In all roof venting applications, exhaust discharge must point away from the pitch of the roof.
6. If the exhaust vent is to be terminated in a walled off area (such as a roof with a parapet wall), ensure the exhaust vent terminates a minimum of 10' from nearest wall and extends level with or above the top of the wall. This will ensure flue gas does not get trapped and possibly recirculated into the intake air pipe, which could contaminate the combustion air.
7. To prevent water leakage, install adequate roof flashing where the pipe enters the roof.
8. Do not locate vent over public walkways, driveways, or parking lots. Condensate could drip and freeze, resulting in a slip hazard or damage to vehicles and machinery.
9. Due to potential moisture build-up, sidewall venting may not be the preferred venting option. To save time and cost, carefully consider venting installation and location.
10. Horizontal lengths of exhaust vent must slope back towards the heater not less than ¼" per foot to allow condensate to drain from the vent pipe.
11. The exhaust vent must terminate where vapors cannot make accidental contact with people or pets, or damage shrubs or plants.
12. In vacant chimney applications, install and seal a rain cap over existing chimney openings.
13. All piping must be fully supported. Use pipe hangers at a minimum of 4 foot intervals to prevent sagging of the pipe where condensate may form.
14. Do not use the heater to support any piping.
15. A screened straight coupling is provided with the heater for use as an outside exhaust termination.
16. A screened inlet air tee is provided with the heater to be used as an outside intake termination.

The following information on Table 7 lists optional intake air/exhaust vent terminations available from HTP.

DESCRIPTION	STOCK CODE
2" PVC CONCENTRIC VENT TERMINATION KIT	KGAVT0501CVT
3" PVC CONCENTRIC VENT TERMINATION KIT	KGAVT0601CVT
2" STAINLESS STEEL VENT TERMINATION KIT	V500
3" STAINLESS STEEL VENT TERMINATION KIT	V1000
4" STAINLESS STEEL VENT TERMINATION KIT	V2000
3" POLYPRO VENT KIT	8400P-001

Table 7

I. VENTING DRAWINGS

DIRECT VENT INSTALLATION OF EXHAUST VENT AND INTAKE PIPE

If installing a direct vent option, combustion air must be drawn from the outdoors directly into the appliance intake, and exhaust must terminate outside. There are two basic direct vent options detailed in this manual: 1. Side Wall Venting and 2. Roof Venting.

Be sure to locate the appliance such that the exhaust vent and intake piping can be routed through the building and properly terminated. Different vent terminals can be used to simplify and eliminate multiple penetrations in the building structure (see Optional

Equipment in Venting Section). The exhaust vent and intake piping lengths, routing and termination methods must all comply with the methods and limits given in the Venting section of this manual.

When installing a combustion air intake from outdoors, care must be taken to utilize uncontaminated combustion air. **NOTE: To prevent combustion air contamination, see Table 1.**

⚠ WARNING

Take extra precaution to adequately support the weight of vent pipes terminating through the roof. Failure to properly support roof terminated vent piping could result in property damage, serious personal injury, or death due to flue gas leakage.

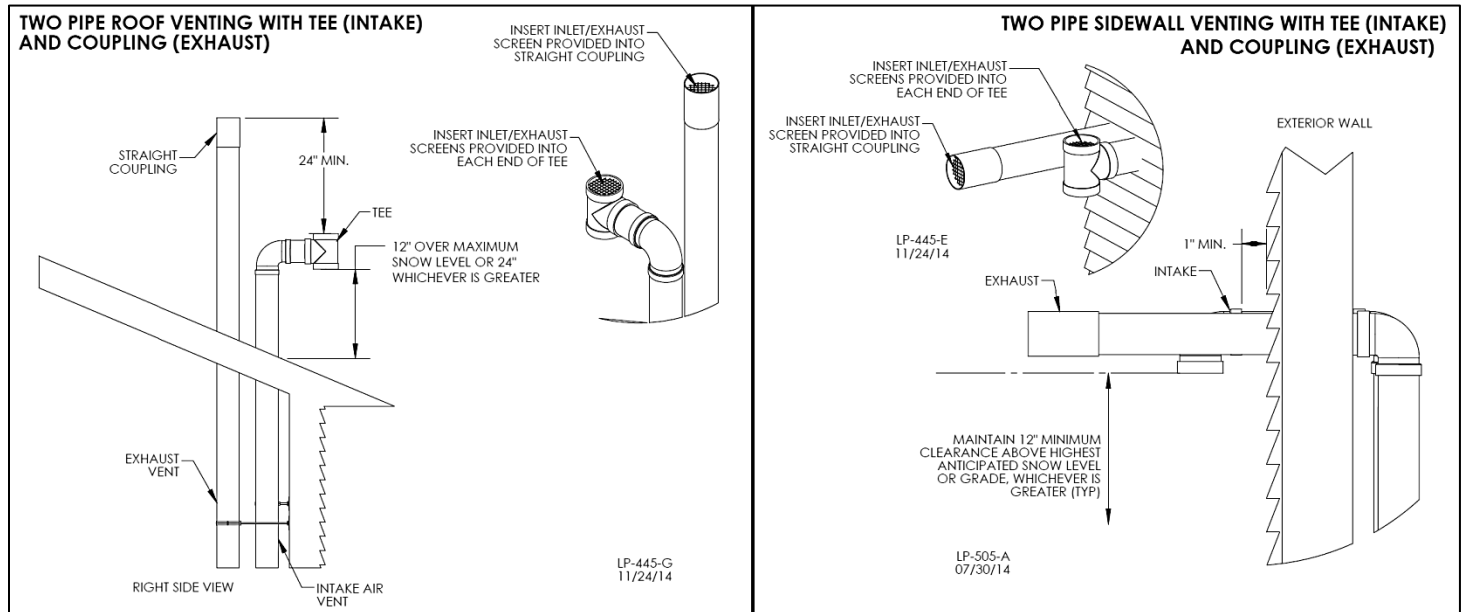

Figure 26 – Two Pipe Roof and Sidewall Venting with Included Equipment (Tee and Coupling) - NOTE: These drawings are meant to demonstrate system venting only. The installer is responsible for all equipment and detailing required by local codes.

⚠ WARNING

All vent pipes must be glued, properly supported, and the exhaust must be pitched a minimum of $\frac{1}{4}$ " per foot back to the heater to allow drainage of condensate. When placing support brackets on vent piping, the first bracket must be within 1 foot of the water heater and the balance at 4 foot intervals on the vent pipe. Heater venting must be readily accessible for visual inspection for the first three feet from the heater.

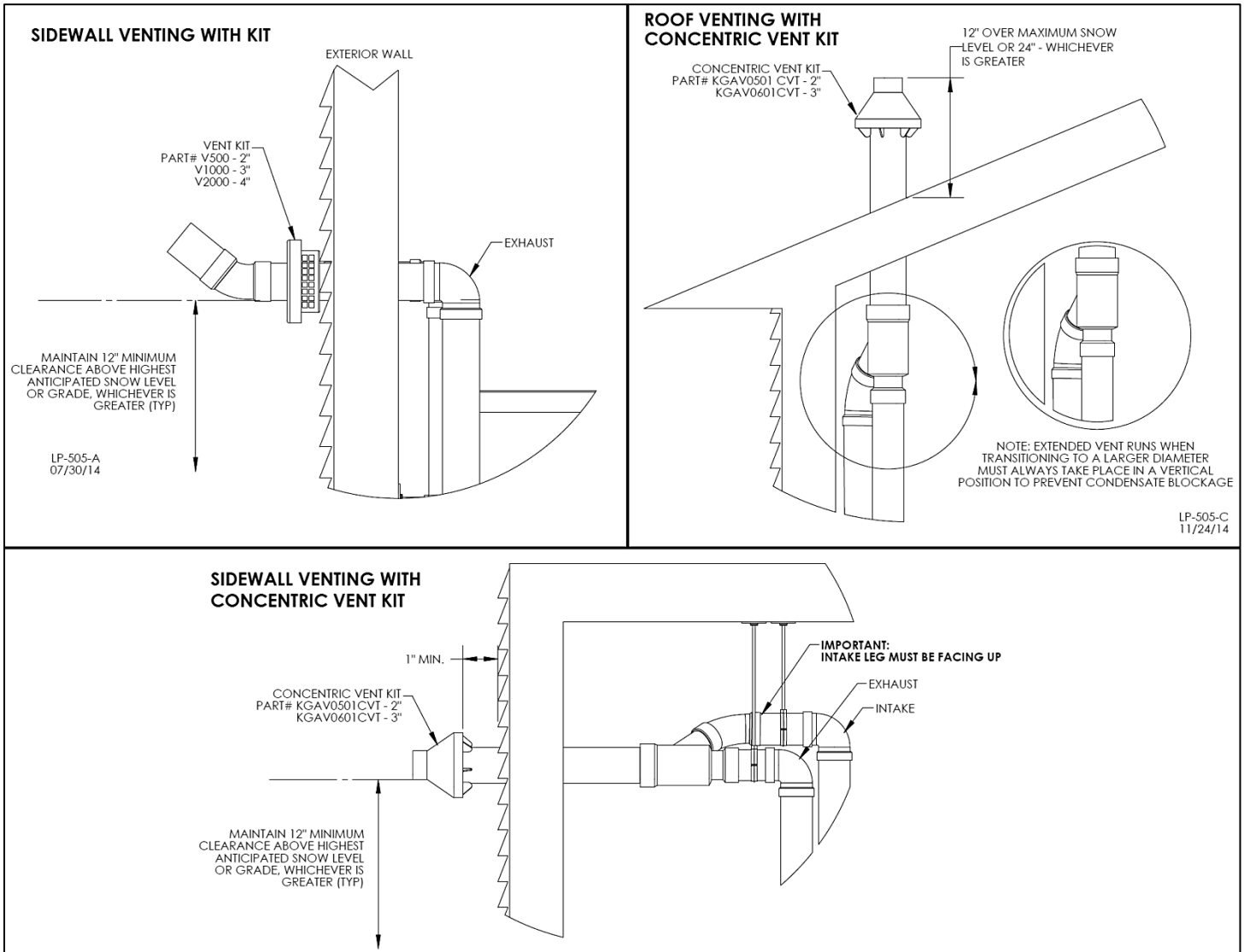

Figure 27 – Venting with Optional Kits (NOT INCLUDED WITH THE WATER HEATER) NOTE: These drawings are meant to demonstrate system venting only. The installer is responsible for all equipment and detailing required by local codes.

⚠ WARNING

All vent pipes must be glued, properly supported, and the exhaust must be pitched a minimum of 1/4" per foot back to the heater to allow drainage of condensate. When placing support brackets on vent piping, the first bracket must be within 1 foot of the water heater and the balance at 4 foot intervals on the vent pipe. Heater venting must be readily accessible for visual inspection for the first three feet from the heater.

PART 8 – GAS PIPING

⚠ WARNING

Failure to follow all precautions in this section could result in fire, explosion, severe injury or death!

A. GAS CONNECTION

Connect the gas supply to the system following state and local plumbing codes. Use the supplied ball valve at the inlet to the system. Make sure the gas supply line fits as shown in Figure 28.

The gas supply shall have a maximum inlet pressure of less than 14" water column (350 mm), ½ pound pressure (3.5 kPa), and a minimum of 3.5" water column. The entire piping system, gas meter and regulator must be sized properly to prevent pressure drop greater than 0.5" WC as stated in the National Fuel Gas Code. This information is listed on the rating plate.

NOTE: Maximum inlet gas pressure must not exceed 14" w.c. (3.5 kPa).

***NOTE:** Installer must supply trap to meet local code requirements.

⚠ DANGER

It is very important that you are connected to the type of gas noted on the rating plate. "LP" for liquefied petroleum, propane gas, or "NAT" for natural or city gas. You must not do a gas conversion without an approved gas conversion kit. Prior to turning the gas on, all gas connections must be approved by the local gas supplier or utility, in addition to the governing authority.

A gas conversion kit comes with the heater. Follow the included instructions VERY carefully. Failure to follow gas conversion instructions could result in property damage, serious injury, or death.

Do not remove the adaptor in Figure 28! It is mandatory that this fitting is used for connection to a field fabricated drip leg per the National Fuel Gas Code. You must ensure that the entire gas line to the connection at the heater is no smaller than ¾".

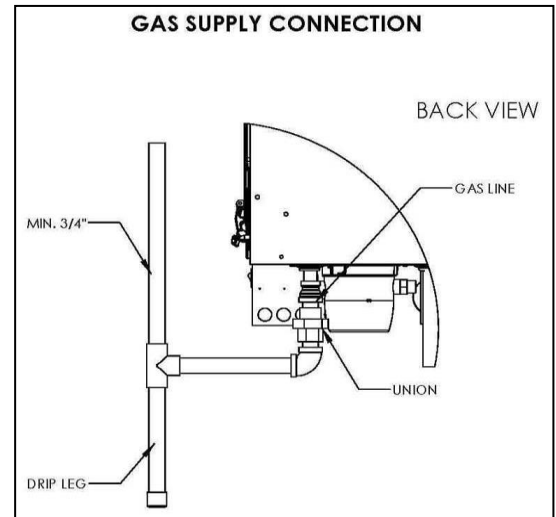

Figure 28 – LP-171-BB

⚠ WARNING

Do not attempt to support the weight of gas piping with the heater or its accessories. The gas valve and blower will not support the weight of the piping. Failure to follow this warning could result in substantial property damage, severe personal injury, or death.

Once all inspections have been performed, the piping must be leak tested. If the leak test requirement is a higher test pressure than the maximum gas inlet pressure, you must isolate the heater from the gas line to continue leak testing. To do this, you must turn off the factory and field-installed gas cocks. This will minimize the possibility of damaging the gas valve. Failure to do so may damage the gas valve. In the event the gas valve is exposed to a pressure greater than ½ PSI, 14" water column, the gas valve must be replaced. Never use an open flame (match, lighter, etc.) to check gas connections.

Refer to the table below to size the supply piping to minimize pressure drop between meter or regulator and unit.

Maximum capacity of pipe in cubic feet of gas per hour for gas pressures of .5 psi or less and a pressure drop of .3 inch water column.

Nominal Iron Pipe Size (Inches)	Internal Diameter (Inches)	Length of Pipe (Feet)														BTU's Per Hour x 1,000
		10	20	30	40	50	60	70	80	90	100	125	150	175	200	
¾	.824	278	190	152	130	115	105	96	90	84	79	72	64	59	55	
1	1.049	520	350	285	245	215	195	180	170	160	150	130	120	110	100	
1 ¼	1.380	1,050	730	590	500	440	400	370	350	320	305	275	250	225	210	
1 ½	1.610	1,600	1,100	890	760	670	610	560	530	490	460	410	380	350	320	

Table 8

It is recommended that a soapy solution be used to detect leaks. Bubbles will appear on the pipe to indicate a leak is present. The gas piping must be sized for proper flow and length of pipe to avoid excessive pressure drop. Both the gas meter and the gas regulator must be properly sized for the total gas load. If you experience a pressure drop greater than 1" WC, the meter, regulator or gas line is undersized or in need of service. You can attach a manometer to the incoming gas drip leg by removing the cap. The gas pressure must remain between 3.5" WC and 14" WC during stand-by (static) mode and while in operating (dynamic) mode at full output.

If an in-line regulator is used, it must be a minimum of 10 feet from the heater. It is very important that the gas line is properly purged by the gas supplier or utility. Failure to properly purge the lines or improper line sizing will result in ignition failure. This problem is especially noticeable in NEW LP installations and also in empty tank situations. This can also occur when a utility company shuts off service to an area to provide maintenance to their lines. The gas valve must not be replaced with a conventional gas valve under any circumstances. As an additional safety feature, the gas valve in this heater has a flanged connection to the swirl plate and blower.

B. GAS PIPING

1. Run the gas supply line in accordance with all applicable codes.
2. Locate and install manual shutoff valves in accordance with state and local requirements.
3. In Canada, the Manual Shutoff must be identified by the installing contractor.
4. It is important to support gas piping as the heater is not designed to structurally support a large amount of weight.
5. Purge all gas lines thoroughly to avoid start up issues with air in the lines.
6. Sealing compound (pipe dope) must be used and approved for gas connections. Apply sparingly, and only to the male threads. Care must be taken when applying compound to prevent blockage or obstruction of gas flow which may affect the operation of the heater.

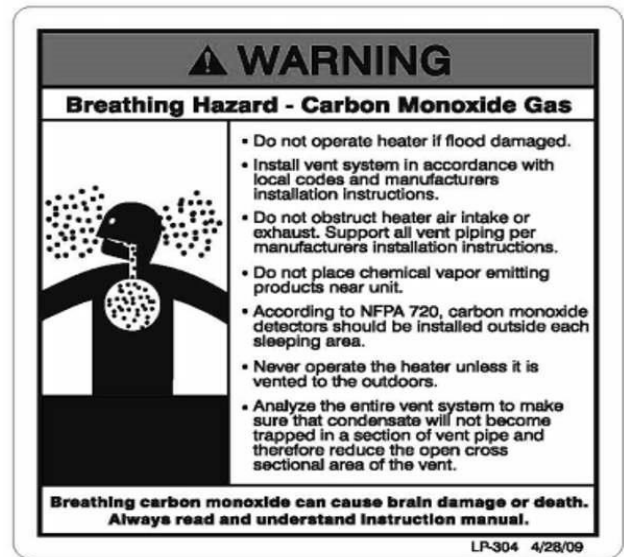

WARNING

Failure to apply pipe sealing compound as detailed above could result in substantial property damage, severe personal injury, or death.

CAUTION

CSA / UL listed flexible gas connections can be used when installing the heater. Flexible gas connections have different capacities and must be sized correctly for the connected heater firing rates. Consult with the flex line supplier to assure the line size is adequate for the job. Follow local codes for proper installation and service requirements.

WARNING

Never use an open flame (match or lighter) to check for gas leaks. Use a soapy solution to test connection. Failure to use a soapy solution test or check gas connection for leaks could result in substantial property damage, severe personal injury, or death.

CAUTION

Use a two-wrench method when tightening gas piping near the heater and its piping connection: One wrench to prevent the heater gas line connection from turning; the second to tighten the adjacent piping. Failure to support the heater gas piping connection could damage the heater beyond repair. Such damage IS NOT covered by warranty.

C. CHECK INLET GAS PRESSURE

The gas valve is equipped with an inlet gas pressure tap that can be used to measure the gas pressure to the heater. To check gas pressure, perform the steps listed below:

1. **IMPORTANT!** Before you connect to the inlet pressure, shut off the gas and electrical power to heater.
2. Loosen the pressure tap with a small screwdriver. Refer to Figure 29 for location.
3. Each heater is equipped with a needle valve that will accept a 5/16 ID hose to connect to a digital manometer or liquid gauge designed to measure incoming pressure from 0-35" w.c. See Figure 29.
4. Turn on the gas and power up the heater.
5. Put the heater into manual test mode (details on test mode are in Part 12 Section D). In service mode, monitor pressure to assure it does not drop below 1 inch from its idle reading. If gas pressure is out of range or pressure drop is excessive, contact the gas utility, gas supplier, qualified installer, or service agency to determine correct action that is needed to provide proper gas pressure to the heater. If Gas Pressure is within normal range proceed to Step 6.
6. Exit test mode, then turn power off and shut off gas supply at the manual gas valve before disconnecting the hose from the gas monitoring device. Tighten screw on the pressure tap and turn gas on. Check for leaks with soapy solution. Bubbles will appear on the pipe to indicate a leak is present.

⚠ WARNING

Ensure the pressure tap screw is properly tightened to prevent gas leaks. Failure to do so could cause substantial property damage, severe personal injury, or death.

The gas piping must be sized for the proper flow and length of pipe to avoid pressure drop. The gas meter and regulator must be properly sized for the total gas load. If you experience a pressure drop greater than 1" w.c. (.87 kPa), the meter, regulator or gas line may be undersized or in need of service. You can attach a manometer to the incoming gas drip leg after removing the cap. The gas pressure must remain between 3.5" (.87 kPa) and 14" (3.5 kPa) during stand-by (static) mode and while in operating (dynamic) mode.

If an in-line high gas pressure regulator is used, it must be installed a minimum of 10 feet from the heater. It is very important that the gas line is properly purged by the gas supplier or utility. Failure to properly purge the lines, or improper line sizing, will result in ignition failure. This problem is especially noticeable in NEW LP installations and empty tank situations. This situation can also occur when a utility company shuts off service to an area to provide maintenance to their lines. This gas valve must not be replaced with a conventional gas valve under any circumstances.

⚠ WARNING

DO NOT adjust or attempt to measure gas valve outlet pressure. The gas valve is factory-set for the correct outlet pressure and requires no field adjustment. Attempts by the installer to adjust or measure the gas valve outlet pressure could result in damage to the valve and cause substantial property damage, severe personal injury, or death.

D. GAS VALVE

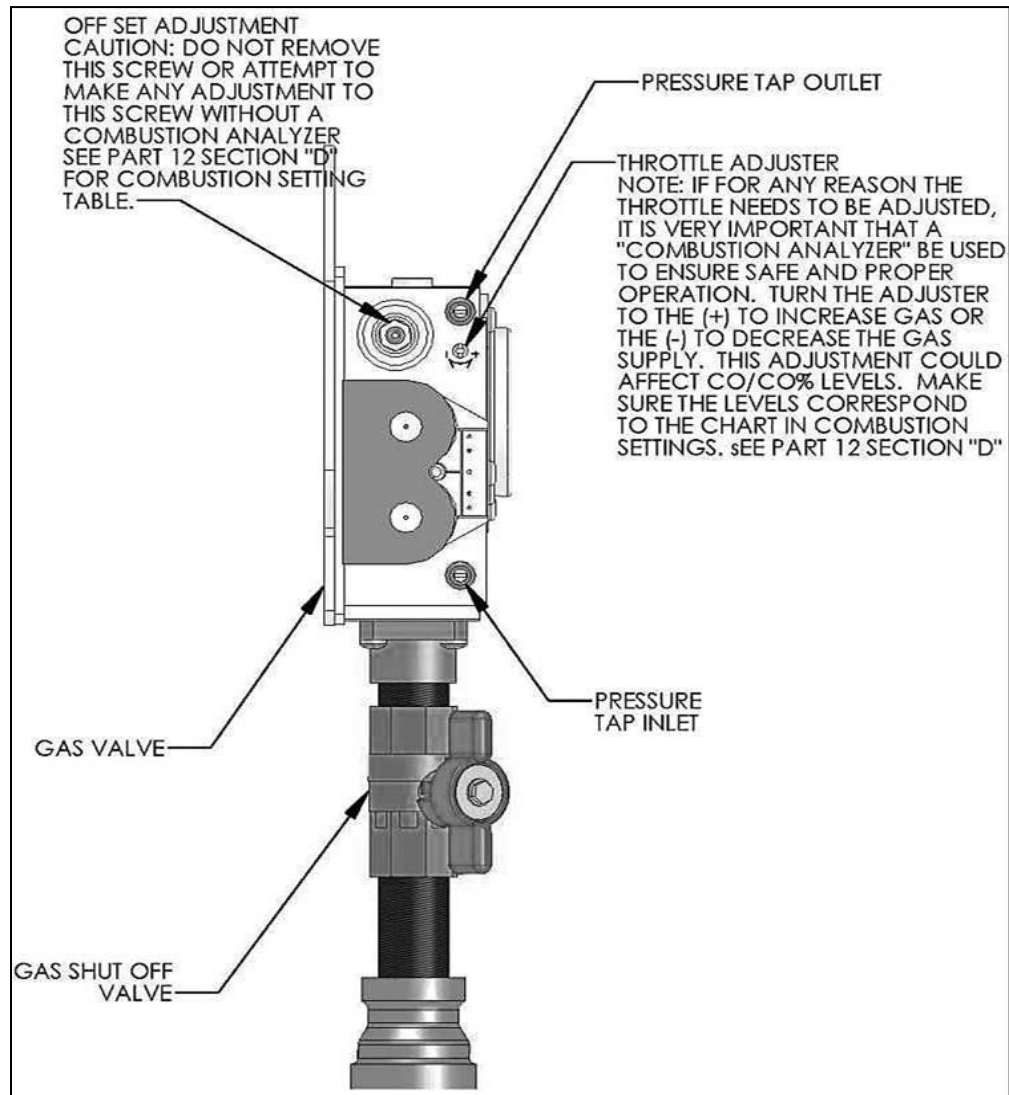

Figure 29 – LP-171-N

⚠ DANGER

Do not do a gas conversion on this heater without an officially approved conversion kit and instructions supplied by HTP. Failure to use a conversion kit when converting the heater to fire on Natural or LP gas will result in extremely dangerous burner operation, leading to fire, explosion, severe injury or death.

⚠ WARNING

Strain on the gas valve and fittings may result in vibration, premature component failure and gas leakage, and result in fire, explosion, property damage, severe personal injury, or death.

⚠ WARNING

Adjustments to the throttle screw or offset may only be made by a qualified gas technician using a calibrated combustion analyzer capable of measuring CO₂ and CO. Failure to follow this instruction could result in fire, explosion, property damage, severe personal injury, or death.

PART 9 – FIELD WIRING**⚠ WARNING**

To avoid electrical shock, turn off all power to the heater prior to opening an electrical box within the unit. Ensure the power remains off while any wiring connections are being made. Failure to follow these instructions could result in component or product failure, serious injury, or death. Such product failure IS NOT covered by warranty.

⚠ WARNING

ELECTRICAL SHOCK HAZARD – Turn off electrical power supply at service entrance panel before making any electrical connections. Failure to do so can cause severe personal injury or death.

CAUTION

Wiring must be N.E.C. Class 1. If original wiring supplied with the heater must be replaced, use only UL Listed TEW 105° C wire or equivalent. Heater must be electrically grounded as required by National Electrical Code ANSI/NFPA 70 – Latest Edition.

⚠ CAUTION

In order to ease future servicing and maintenance, it is advised to label all wires. Wiring errors can cause improper and dangerous operation. Failure to follow these instructions could result in property damage or personal injury.

A. INSTALLATION MUST COMPLY WITH:

National Electrical Code and any other national, state, provincial or local codes or regulations.

In Canada, CSA C22.1 Canadian Electrical Code Part 1, and any local codes.

B. FIELD WIRING

For your convenience we have located the electrical connection of the heater on the front right hand side of the unit. The electrical junction box has a 24 volt terminal compartment and 120 volt terminal compartment. Each terminal connection is clearly marked to assure correct installation.

C. LINE VOLTAGE WIRING

1. Connect 120 VAC power wiring to the line voltage terminal strip located inside the electric junction box, as shown in Figure 31.
2. Wire the Heater Primary Circulator (P1) to the terminal strip. See wiring diagram in this section.

D. THERMOSTAT

1. Connect room thermostat or end switch.
2. Install thermostat on inside wall away from influences of drafts, hot or cold water pipes, lighting fixtures, television, sunrays or fireplaces.
3. Thermostat anticipator (if applicable):
 - a. If connected directly to heater, set for 0.1 amps.
 - b. If connected to relays or other devices, set to match total electrical power requirements of connected devices. See specifications of the device and thermostat instructions for details.

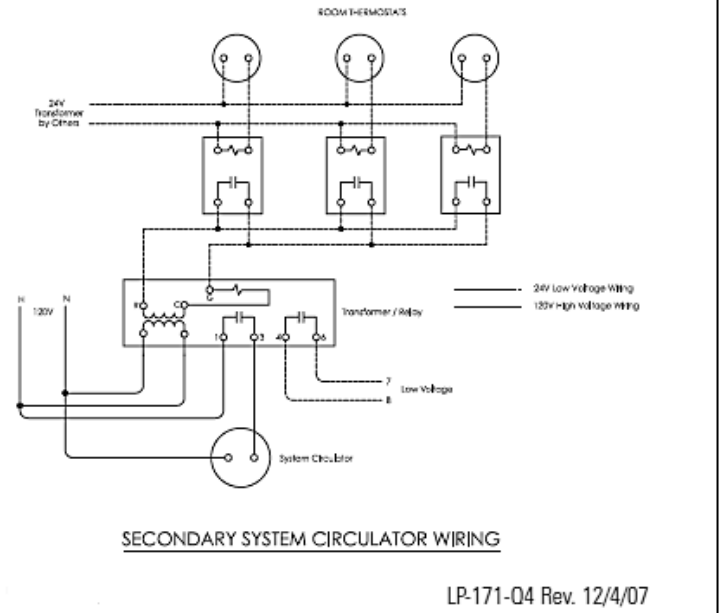
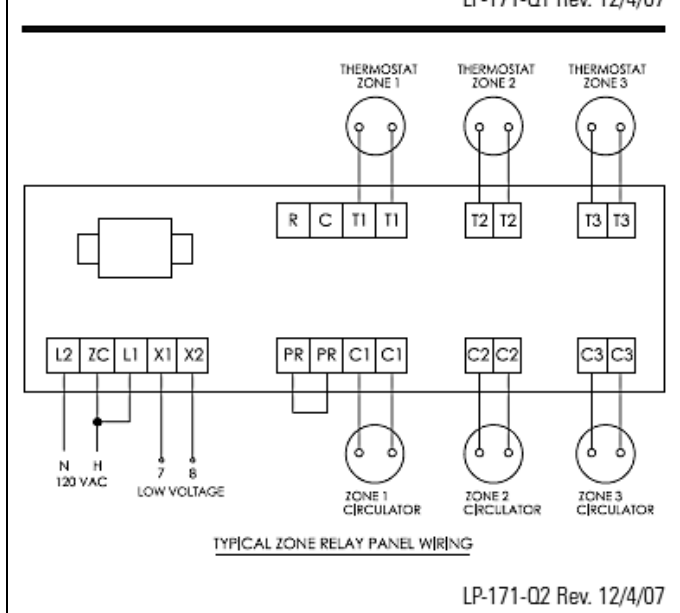
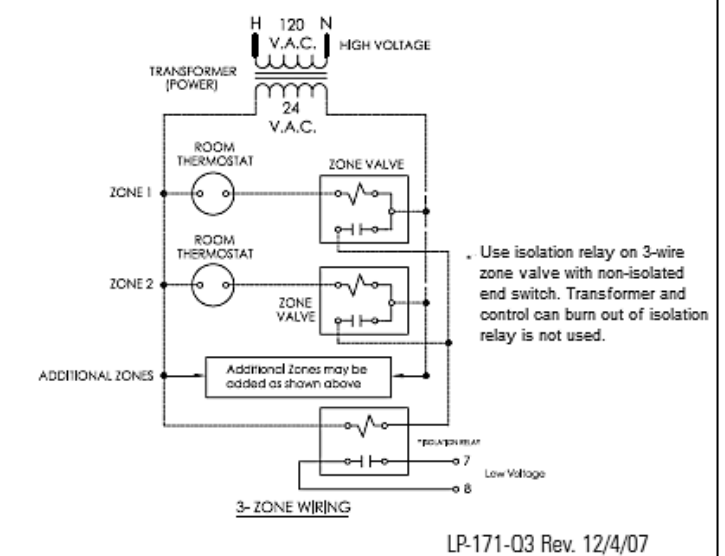
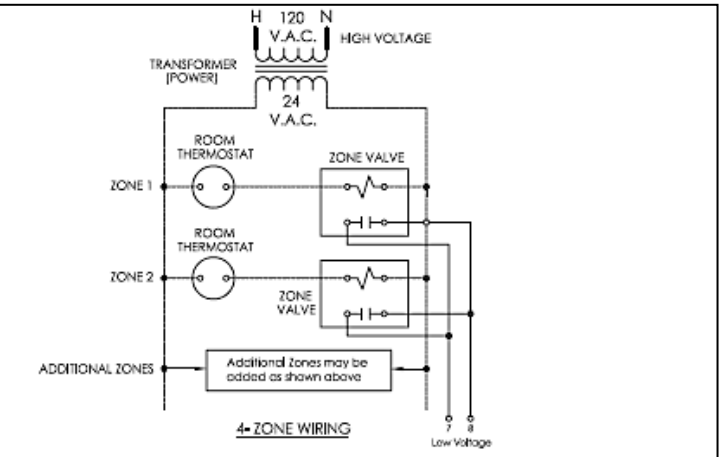
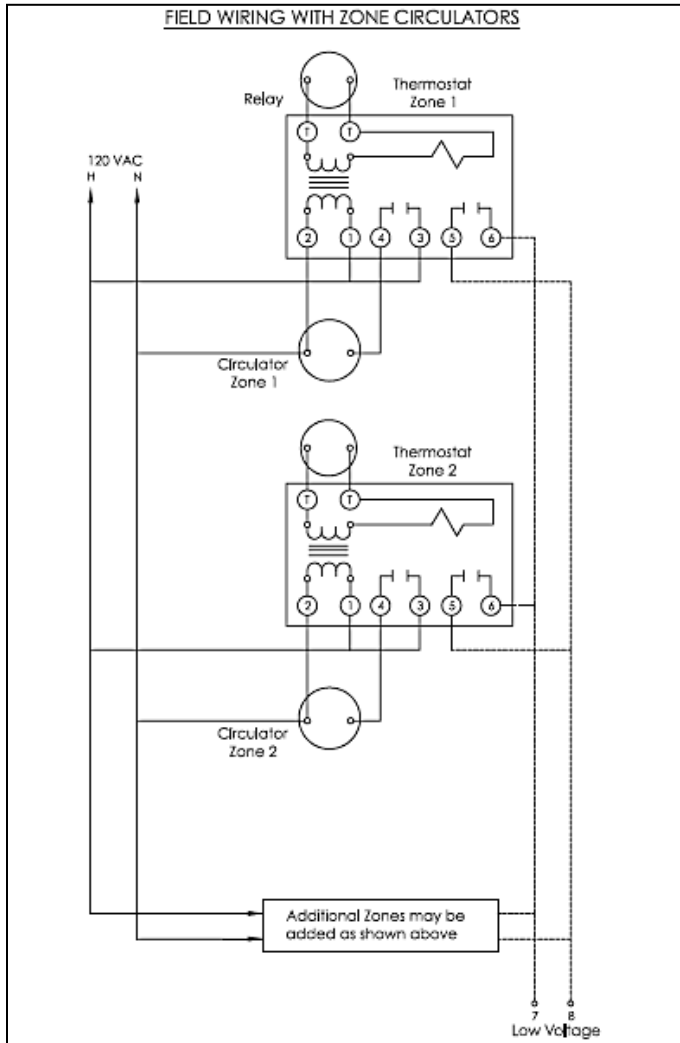

Figure 30

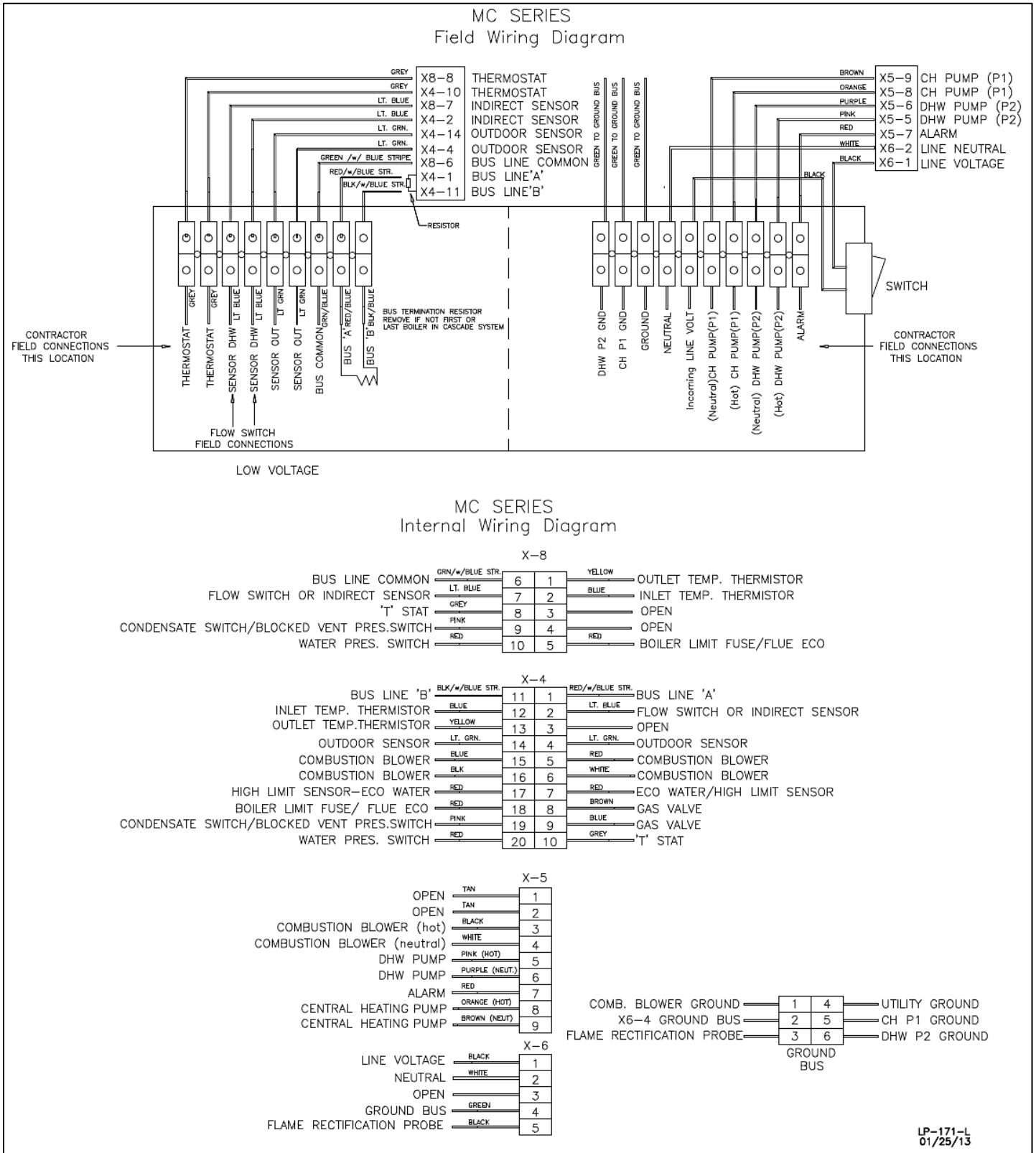

Figure 31 – NOTE: A resistor is provided between Bus Lines A and B. DO NOT REMOVE THIS RESISTOR! DOING SO WILL EFFECT HEATER OPERATION AND VOID WARRANTY!

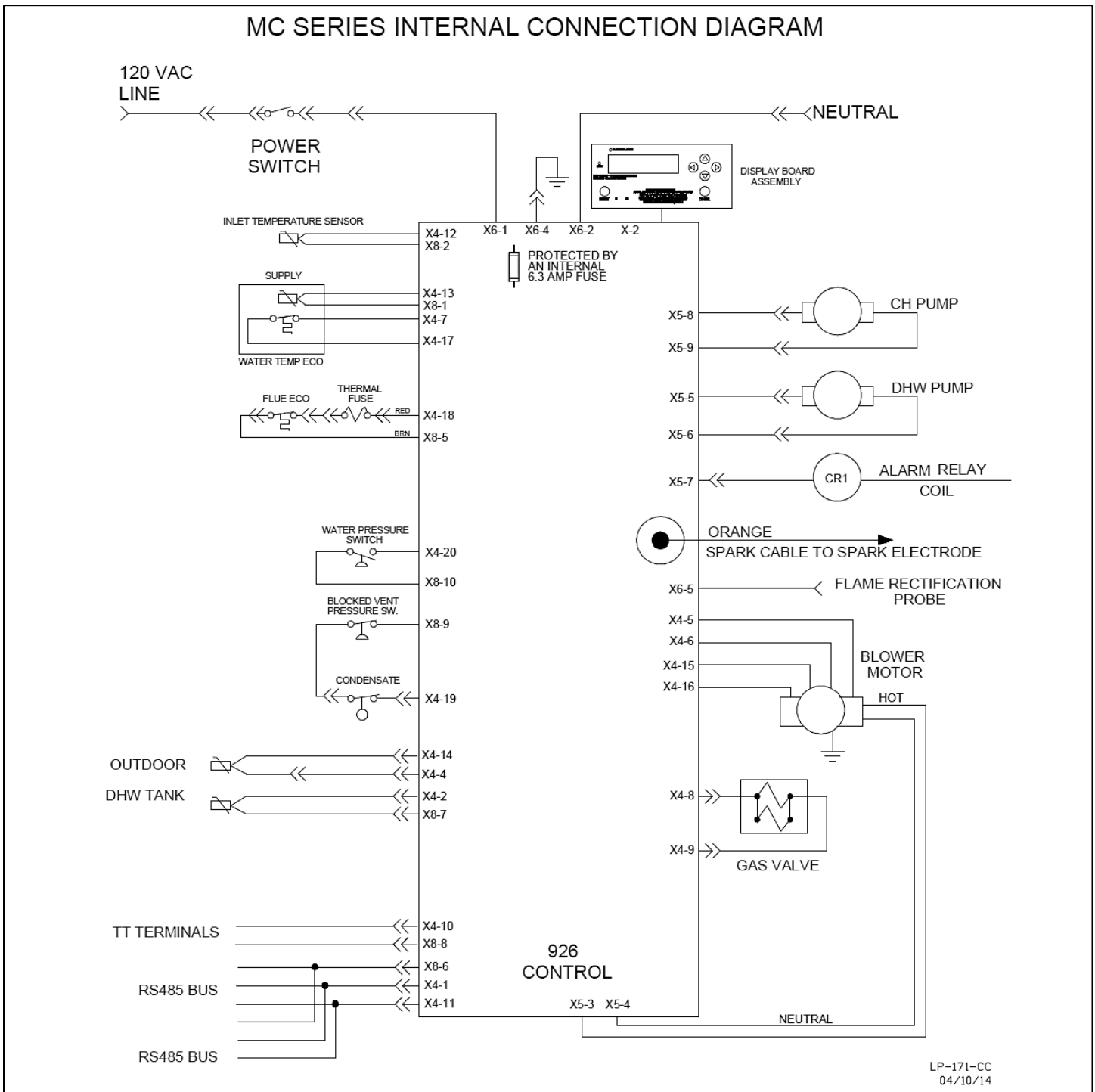

Figure 32 – MC Series Internal Connection Diagram

PART 10 – FIELD WIRING – VISION 1 OPTION

Outdoor Sensor Function

The user can program the desired supply temperature based on the heat transmitter (baseboard, radiant floor, air handler) that will be used in the installation. Once the outdoor sensor (light green wires) is connected to the control board, the water temperature of the heater will adjust to run the heater more efficiently and provide greater comfort to the living space.

Connection Specification – Wire 22 AWG maximum to 100 feet or 18 AWG up to 150 feet. Length of wire run cannot exceed 150 feet.

Outdoor Sensor

NOTE: If the system requires a fixed operating temperature, the outdoor sensor is not required and should not be installed.

Connected in the heater junction box, the Outdoor Sensor allows the user to automatically change the temperature going to the central heating loop. Route wires from the heater terminal strip to your outdoor sensor. Place the sensor preferably to the north or northwest or to the side which will be affected by changing weather conditions outside. **NOTE:** Do not locate the sensor in the direct sunlight.

CAUTION

The wire to outdoor sensor must not be laid closer than 6' to line voltage wiring (120/240 V) and must never be in the same conduit.

NOTE: For correct mounting procedures, follow instructions provided with the sensor.

NOTE: If sensor wires are located in an area with sources of potential electromagnetic interference (EMI), the sensor wires should be shielded, or the wires routed in a grounded metal conduit. If using shielded cable, the shielding should be connected to the common ground of the heater.

Indirect Sensor Function

The maximum run time on priority function for the SuperStor Ultra Indirect Fired Water Heater is from 1-60 minutes. The water temperature can only be adjusted when using a sensor (not a mechanical control). Temperature adjustments are from 95 to 185 degrees, plus a differential 1-18 degrees (Note: It is recommended that you do not exceed 5 minutes on the DHW pump post purge cycle to avoid cooling down your DHW tank).

Indirect Sensor

The Indirect Sensor connects to the heater main control. Route wires from the terminal strip to the sensor or the mechanical control, Honeywell part # L4080b1395 (not included in Vision I Package), into the control well located in the front of the water heater. This will allow the installer to control the temperature of the indirect from the heater and give the indirect priority over the central heating circuit. Once the indirect is satisfied, the heater will then switch back to central heating if there is a call for heat. If not, the heater will then shut down.

⚠ WARNING

Caution should be used to ensure neither of these terminals becomes connected to ground.

NOTE: If sensor wires are located in an area with sources of potential electromagnetic interference (EMI), the sensor wires should be shielded, or the wires routed in a grounded metal conduit. If using shielded cable, the shielding should be connected to the common ground of the heater.

⚠ WARNING

Failure to use the correct sensor may result in tank temperature being either above or below set point, and could result in decreased performance, substantial property damage, or heightened risk of injuries due to scalds.

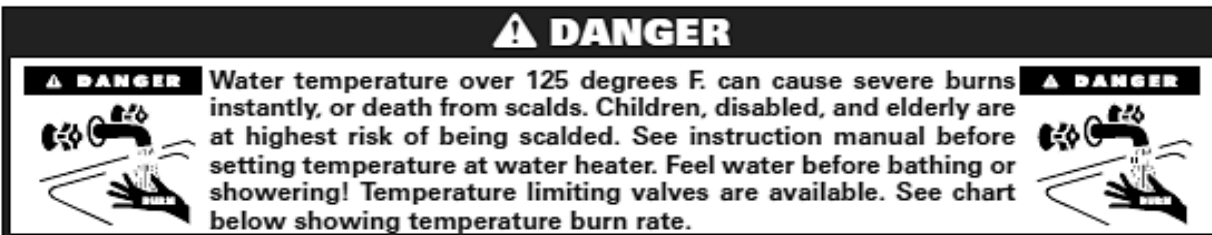

Indirect Circulator (P2) Program Function

The Indirect Circulator Program Function will automatically start when the water heater sensor reads a call for heat. The installer can also program the post purge function on the circulator. The post purge circulator function ranges from 1-30 minutes.

Indirect Circulator (P2)

The Indirect Circulator connects to the heater terminal strip. Run wire to the SuperStor Ultra Indirect circulating pump. The purple wire is the neutral lead and the pink wire is the hot. This will supply 120 volts directly to the water heater circulator.

Fault Code Alarm Output

The Fault Code Alarm Output connects to the heater main control. Route wire from the heater controller to an external relay or an audible alarm. The red wire will be your hot lead supplying 120 volts. The neutral connection will be connected to the neutral on the incoming power to the heater.

CAUTION

Do not tie neutrals or hot wire leads to any other wires. Go directly from the heater controller to the circulator.

Connection Specification – Wire 18 AWG maximum. Length of wire run cannot exceed 100 feet.

PART 11 – START-UP PREPARATION

WARNING

Thoroughly clean and flush any system that has used glycol before installing the heater. Provide the customer with a material safety data sheet (MSDS) on the fluid used.

A. CHECK/CONTROL WATER CHEMISTRY

CAUTION

Chemical imbalance of your water can cause severe damage to your heater and associated equipment, and may also affect efficiency. You may have to have your water quality professionally analyzed to determine whether you need to install a water softener. It is important that the water chemistry on both the domestic hot water and central heating sides are checked before installing the heater, as water quality will affect the reliability of the system. Outlined below are those water quality parameters which need to be met in order for the system to operate efficiently for many years. **Failure of a heat exchanger due to lime scale build-up on the heating surface, low pH or other imbalance IS NOT covered by the warranty.**

To assure extended service life, it is recommended to test water quality prior to installation. Listed below are some guidelines.

WARNING

Do not use petroleum-based cleaning or sealing compounds in heater system. Damage to elastomer seals and gaskets in system could occur, resulting in substantial property damage.

Sodium less than 20 mGL

Water pH between 6.0 and 8.0

1. Maintain heater water pH between 6.0 and 8.0. Check with litmus paper or have chemically analyzed by water treatment company.
2. If pH differs from above, consult local water treatment company for treatment needed.

Hardness less than 7 grains

Consult local water treatment companies for unusually hard water areas (above 7 grains hardness).

Chlorine concentration less than 100 ppm

1. Filling with chlorinated fresh water should be acceptable since drinking water chlorine levels are typically less than 5 ppm.
2. Do not use the heater to directly heat swimming pool or spa water.
3. Do not fill heater or operate with water containing chlorine in excess of 100 ppm.

Clean system to remove sediment

1. You must thoroughly flush the system (without heater connected) to remove sediment. The high-efficiency heat exchanger can be damaged by buildup or corrosion due to sediment.
2. For zoned systems, flush each zone separately through a purge valve. (If purge valves and isolation valves are not already installed, install them to properly clean the system.)
3. Flush system until water runs clean and you are sure piping is free of sediment.

Test/replace freeze protection fluid

1. For systems using freeze protection fluids, follow fluid manufacturer's instructions to verify inhibitor level and that other fluid characteristics are satisfactory.
2. Freeze protection fluid must be replaced periodically due to degradation of inhibitors over time. Follow all fluid manufacturer instructions.

NOTE: Heater failure due to improper water chemistry is not covered by warranty.

B. FREEZE PROTECTION (WHEN USED)**CAUTION**

NEVER use automotive or standard glycol antifreeze, or ethylene glycol made for hydronic systems. System water, including additives, must be non-toxic, having a toxicity rating or Class of 1, as listed in Clinical Toxicology of Commercial Products. Use only freeze-prevention fluids certified by fluid manufacturer as suitable for use with stainless steel heaters, verified in fluid manufacturer literature. Thoroughly clean and flush any system that has used glycol before installing the new heater. Provide heater owner with a material safety data sheet (MSDS) on the fluid used.

1. Determine freeze protection fluid quantity using total system water content, following fluid manufacturer's instructions. Remember to include expansion tank water content.
2. **NOTE:** Local codes may require back flow preventer or actual disconnect from city water supply.
3. When using freeze protection fluid with automatic fill, install a water meter to monitor water makeup. Freeze protection fluid may leak before the water begins to leak, causing concentration to drop, reducing the freeze protection level.

C. FILL AND TEST WATER SYSTEM**⚠ WARNING**

Ensure the heater is full of water before firing the burner. Failure to do so will damage the heater. Such damage IS NOT covered by warranty, and could result in property damage, severe personal injury, or death.

1. Fill system only after ensuring the water meets the requirements of this manual.
2. Close manual and automatic air vents and heater drain valve.
3. Fill to correct system pressure. Correct pressure will vary with each application.
 - a. Typical cold water fill pressure for a residential system is 12 psi.
 - b. Pressure will rise when heater is turned on and system water temperature increases. Operating pressure must never exceed 25 psig.
4. At initial fill and during heater startup and testing, check system thoroughly for any leaks. Repair all leaks before proceeding further.

⚠ WARNING

Eliminate all system leaks. Continual fresh make-up water will reduce heater life. Minerals can build up in the heat exchanger, reducing heat transfer, overheating heat exchanger, causing heat exchanger failure, and possibly resulting in property damage, severe personal injury, or death.

5. The system may have residual substances that could affect water chemistry. After the system has been filled and leak tested, verify water pH and chlorine concentrations are acceptable.

D. AIR PURGING PROCEDURE FOR HEAT EXCHANGER**CAUTION**

It is important that you purge the system of air to avoid damage to the heater. Make sure that this procedure is followed before firing the heater.

⚠ WARNING

The heater must be room temperature before attempting to purge air from the heat exchanger purge valve. The supplied tubing is rated to 120°F maximum.

The control system allows the installer to run the heater pump and indirect pump manually to assist in purging air from the system. This feature, in combination with the supplied purge hose and fitting on the heat exchanger, will help to remove air from the heat exchanger and hydronic piping system.

To remove air from the system, follow the steps listed on the following page:

CAUTION

Open manual air vent **BY HAND ONLY!** Use of tools, such as wrenches or pliers, can snap or crack the valve. **NOTE: This damage IS NOT COVERED BY WARRANTY!**

1. Take the 5/16" flexible clear tube (rated for maximum temperature of 120°F) provided with the heater and place it over the barbed nipple on the manual air vent as shown in Fig. 31.
2. Fasten the tie wrap (provided) securely around the tube fastened to the barbed nipple on the manual air vent to keep the plastic tube from separating from the barbed nipple while purging the system.
3. Turn the manual air vent to the open position as shown in Fig. 31. Air and water should drain freely from the system.
4. Close the manual air vent when ONLY water flows freely from the end of the hose.
5. Follow the guidelines in Section E in this section to purge each individual zone in the system.
6. Remove any electrical connections to the Thermostat terminals and DHW sensor terminals of the heater. This will prevent the heater from firing when the power is applied.
7. Apply power to the heater, making sure that the thermostat terminals are not connected. The display will show you the temperature of the water and/or air in the heat exchanger.

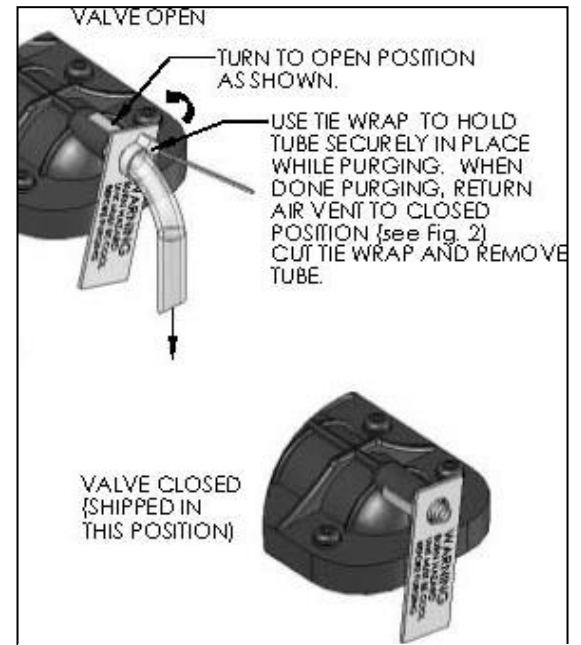

Figure 33

⚠ WARNING

Do not open purge valve if displayed temperature is greater than 90°F.

8. Press the **[S1]** and **[S3]** keys on the display simultaneously and hold for 1 second. The display will begin alternating between SEP and CH and the heater pump will come on. If you press the **[S2]** key, the heater pump will shut off, the display will begin alternating between SEP and DH and the DHW pump will come on. Using the **[S1]** and **[S2]** keys in this manner you can toggle between running each pump in the system as required to help bleed out all entrapped air. Some good indicators that air is removed include the absence of gurgling noises in the pipes and the pump operation becomes very quiet. Pressing **[S1]** and **[S2]** together at any time will return the heater control to normal operation.

NOTE: IF THE INSTALLER DOES NOT CANCEL THIS FUNCTION BY PRESSING **[S1] AND **[S2]** TOGETHER, THE PUMPS WILL RUN FOR A MAXIMUM OF 20 MINUTES AND SHUT OFF AUTOMATICALLY.**

9. While the pump is running as described above, open the manual air vent on the front of the heat exchanger as shown in Fig. 31 to further assist in removing air from the system.
10. When all air is removed and water runs freely from the end of the hose, return air vent to the closed position shown in Fig. 31. Cut the tie wrap and remove the tube. Please make sure warning tag is left in place. Stop the pump from running by pressing **[S1]** and **[S2]** together.
11. Reconnect the thermostat and DHW sensor wires to the appropriate terminals on the low voltage terminal strip and fire the heater.
12. If heater makes ping sounds SHUT DOWN IMMEDIATELY and repeat the procedure outlined above until all the air is out of the system. To avoid overheating and damage to the heat exchanger, it is recommended that the heater temperature be brought up slowly if air purging had been a problem.

E. PURGE AIR FROM WATER SYSTEM

1. Purge air from system:
 - a. Connect a hose to the purge valve and route hose to an area where water can drain and be seen.
 - b. Close the heater or system isolation valve between the purge valve and fill connection to the system.
 - c. Close zone isolation valves.
 - d. Open quick-fill valve on cold water makeup line.
 - e. Open purge valve.
 - f. One zone at a time, open the isolation valves. Allow water to run through the zone, pushing out the air. Run until no noticeable air flow is present. Close the zone isolation valves and proceed with the next zone. Follow this procedure until all zones are purged. After all the zones are purged, open the manual air vent on the top of the heat exchanger as illustrated in Figure 33. Purge out all air that may have accumulated in the header to avoid air entrapment in the system.

WARNING

Never open the manual air vent while the heater is hot. Allow heater to cool to room temperature to avoid scalding while purging.

- g. Close the quick-fill water valve and purge valve and remove the hose. Open all isolation valves. Watch that system pressure rises to correct cold-fill pressure.
- h. After the system has operated for a while, eliminate any residual air by using the manual air vents located throughout the system.
- i. If purge valves are not installed in system, open manual air vents in system one at a time, beginning with lowest floor. Close vent when water squirts out. Repeat with remaining vents.
- j. Refill to correct pressure.

F. CHECK FOR GAS LEAKS

WARNING

Before starting the heater, and during initial operation, smell near the floor and around the heater for gas odorant or any unusual odor. Remove heater front door and smell interior of heater enclosure. Do not proceed with startup if there is any indication of a gas leak. Repair any leak at once.

WARNING

Propane heater only – Your propane supplier mixes an odorant with the propane to make its presence detectable. In some instances, the odorant can fade, and the gas may no longer have an odor. Before startup (and periodically thereafter), have the propane supplier verify the correct odorant level in the gas.

G. CHECK THERMOSTAT CIRCUIT(S)

1. Disconnect the two external wires connected to the heater thermostat terminals (low voltage terminal strip terminals 5 and 6).
2. Connect a voltmeter across these two incoming wires. Close each thermostat, zone valve and relay in the external circuit one at a time and check the voltmeter reading across the incoming wires.
3. There should NEVER be a voltage reading.
4. If a voltage does occur under any condition, check and correct the external wiring. (This is a common problem when using 3-wire zone valves.)
5. Once the external thermostat circuit wiring is checked and corrected if necessary, reconnect the external thermostat circuit wires to heater low voltage terminal strip. Allow the heater to cycle.

H. CONDENSATE REMOVAL

1. This a high efficiency condensing heater, there, the unit has a condensation drain. Condensate is nothing more than water vapor, derived from combustion products, similar to an automobile when it is initially started. The condensation is slightly acidic (typically with pH of 3 to 5) and must be piped with the correct materials. Never pipe the condensate using steel, copper, brass or other materials that will be subject to corrosion. Plastic PVC or CPVC pipe are the only approved materials. A condensate filter, if required by local authorities, can be made up of lime crystals marble or phosphate chips that will neutralize the condensate. This may be done by the installer or you may purchase a condensate neutralizer from HTP (p/n N1100).
2. The heater is equipped with a ¾ pipe connection that runs the condensation line to a local drain. It is very important that the condensate line is sloped away from the heater and down to a suitable inside drain. If the condensate outlet is lower than the drain, you must use a condensate removal pump, available at HTP (#554200). This pump is equipped with two leads that can be connected to an alarm or another type of warning device to alert residents of a condensate overflow, which, if not corrected, could cause property damage.
3. If a long horizontal run is used, it may be necessary to create a second vent to prevent a vacuum lock in the condensate line. Do not expose the condensate to freezing temperatures.
4. Do not expose the condensate to freezing temperatures.
5. It is very important you support the condensation line to assure proper drainage.

I. FINAL CHECKS BEFORE STARTING HEATER

1. Read Startup Procedures within this manual for proper steps to start heater. (See Startup Report to record steps for future reference.)
2. Verify the heater and system are full of water and all system components are correctly set for operation.

3. Fill condensate trap with water.

4. Verify electrical connections are correct and securely attached. Inspect exhaust vent and intake piping for signs of deterioration from corrosion, physical damage or sagging.

PART 12 – START-UP PROCEDURE

⚠ WARNING

FOR YOUR OWN SAFETY READ BEFORE OPERATING

1. This heater does not have pilot. It is equipped with an ignition device which automatically lights the burner. Do not try to light the burner by hand.

2. BEFORE OPERATING: smell all around the heater area for gas. Be sure to smell next to the floor because some gas is heavier than air and will settle on the floor.

WHAT TO DO IF YOU SMELL GAS

- Do not try to light any heater.
- Do not touch any electric switch; do not use any phone in your building.
- Immediately call your gas supplier from a neighbor's phone. Follow the gas suppliers' instructions.
- If you cannot reach your gas supplier, call the fire department.
- Turn off gas shutoff valve (located outside of the heater) so that the handle is crosswise to the gas pipe. If the handle will not turn by hand, don't try to force or repair it, call a qualified service technician. Force or attempted repair may result in a fire or explosion.

4. Do not use this heater if any part has been under water. Immediately call a qualified service technician to inspect the heater and to replace any part of the control system and any gas control that has been damaged.

5. The heater shall be installed so the gas ignition system components are protected from water (dripping, spraying, rain, etc.) during heater operation and service (circulator replacement, condensate trap, control replacement, etc.)

Failure to follow these instructions could result in property damage, serious personal injury, or death.

A. OPERATING INSTRUCTIONS

Remove heater cover. If you smell gas, STOP. Follow listed safety instructions. If you do not smell gas, follow the next steps.

1. Turn on all electric power to heater.
2. If desired, adjust the temperature set point of the heater. The factory default setting is 180°F. If changes are necessary follow "Adjusting the Set point" in this section.
3. Set the thermostat to the desired setting.
4. If the heater fails to start, refer to the "Troubleshooting" section in the back of this manual.

B. ADJUSTING THE SET POINT

1. Before changing the temperature from the factory setting of 180 degrees, you must make sure that none of the thermostats are calling for heat. The controller will not memorize a program setting while in a heating cycle.

To adjust the heater temperature simply press in the **[S3]** key for three seconds until you see a flashing **(C)** then an alternate value of **(180)**. This number is the factory set point of the unit, which is 180 degrees. To change the temperature, simply push either **[S1]** or **[S2]** on the display. **[S1]** decreases and **[S2]** increases the heater temperature. The temperature of the heater can be set as low as 50 Degrees or as high 180 Degrees. These ranges are your minimum and maximum heater temperature ranges.

In addition to changing the temperature, you may also change three more settings in this model: 1. heater differential, 2. indirect setting (**with Vision System option**), and 3. Celsius to Fahrenheit measurement. Simply press **[S3]** to get to next value, the heater differential setting will appear in the display **ch and alternating value of 30**. This allows the installer to adjust the activation of the burner based on the differential temperature setting of the heater. The burner will not start until the outlet water temperature reaches a temperature equal to the setting for the heater, minus the differential EX: The heater is set to heat at 180°F degrees and the differential is set at 30°F. The burner will not start until the outlet temperature of the system reaches 149°F degrees (180° – 30°F = 150°F).

⚠ DANGER



Water temperature over 125 degrees F. can cause severe burns instantly, or death from scalds. Children, disabled, and elderly are at highest risk of being scalded. See instruction manual before setting temperature at water heater. Feel water before bathing or showering! Temperature limiting valves are available.

To adjust, press either **{S1}** (Decrease Value) or **{S2}** (Increase Value) Ranges 5°F to 30°F. Press **{S3}** again and you will see the Indirect Setting de and an alternative value of 119 (with Vision Systems option). To adjust, press either **{S1}** (Decrease Value) or **{S2}** (Increase Value).

The final adjustment in this mode is the Fahrenheit to Celsius measurement. Press **{S3}** again and you will see t and alternating value of F. To change value, press **{S1}** or **{S2}** to choose the correct measurement.

C. STATUS MENU

Installers are also able to check the current status of heater parameters by pressing **{S4}** for 3 seconds. Once activated, the display will show **d1** alternating value of the actual outlet temperature. Actual values are displayed for each function. To view the next value, press **{S4}** to go to the next displayed value. Listed below are the values which can be displayed. These values cannot be changed. To exit this menu, simply press **{S3}** to resume normal operation.

Function Value

- d1 — Actual Temperature from outlet sensor
- d2 — Actual Temperature from inlet sensor
- d3 — If using a standard mechanical control, the control will display **1** for closed **0** for open. If the sensor is connected to the SuperStor Indirect Fired Water Heater it will measure the actual temperature (Vision option).

Function Value

- d4 — Not used
- d5 — Actual Temperature from the outdoor sensor (Vision option).
- d6 — Actual Fan speed multiplied by 10 (Example: If fan speed displayed is **410** RPM x 10 = 4100 actual fan speed)
- d7 — Actual Ionization current read from Flame Rectification probe
- d8 — Actual Status of the Central Heating Circulator Off = **0**, On = **1**. (Vision option.)
- d9 — Actual Status of the Indirect Fired Circulator Off = **0**, On = **1**. (Vision option.)
- d10 — Actual Status bus communication **co** = connected, **no** = not connected
- d11 — Central Heating Set Point
- d12 — Power On Hours in units
- d13 — Total Central Heat Hours
- d14 — Total Indirect/dhw Hours
- d15 — Passed Ignition Attempts

D. TEST MODE

This function is intended to simplify the gas valve adjustment if needed. Listed below are the recommended limits on each heater and the combustion settings. Automatic modulation does not take place when the controller is in Test mode, only temperature limitation based on the heater central heating set point. The user will be allowed to increase or decrease the fan speed by pressing in either **{S1}** or **{S2}**.

To activate Test mode, press **{S2}** and **{S3}** together for 1 second. Once activated, you will see **{Ser}** in the display and the actual fan speed. The measurement of the combustion levels should always be taken at the highest and lowest fan speed. After 10 minutes, the Test mode stops automatically. To exit Test mode, press **{S1}** and **{S2}** together for 1 second.

COMBUSTION SETTINGS ON ALL MODELS						
Fan Speed	Natural Gas			Propane LP		
	Low	Ignition	High	Low	Ignition	High
Carbon Monoxide PPM	5 – 50	60 – 100	≤ 150	5 – 50	60 - 140	≤ 150
Carbon Dioxide (CO ₂)	8 - 10%	8 ½ – 10 ½%		8 ½ - 10 ½%	9 - 10 ½%	9 - 11%

Table 9

FAN SPEEDS			
HEATER	HIGH	LOW	IGNITION
MC-50	3300	1250	3000
MC-80	4250	1200	4250
MC-99	4700	1500	3000
MC-120	5500	1500	3000

Table 10

PART 13 – START-UP PROCEDURES WITH VISION 1 OPTION

The Vision I option allows the user to have one temperature for central heating and another temperature for the SuperStor Ultra Indirect Fired Water Heater. This enables the user to increase the temperature supplied to the indirect water heater by prioritizing flow at a higher temperature than may be needed for the central heating circuits (this will require two separate circulators). Once the indirect

water heater is satisfied, the Vision I system will switch back to the central heating circuit to continue to heat the living space at a temperature based on outside temperature. This gives you a higher comfort level and further increases heater efficiency.

A. PROGRAMMING THE VISION I OPTION

The Vision I option allows the installer to set the system limits and heat curve for the heater. These system limits should not be changed by the user. For future reference, it is important to document your settings within this manual after you program the system parameters.

B. VISION 1 PROGRAM ACCESS

Press and hold [S3] and [S4] simultaneously for three seconds to begin. You will notice that the display will change to [000]. Then, press down [S1] until you see [925] on the display. This is the pass code. Press and hold [S3] for 1 second to confirm the pass code is correct. If the pass code is entered incorrectly, the controller program function will be cancelled and the control returns to normal operation. If the code is entered correctly, the control will switch off the gas valve and purge fan while showing a solid [---] in the display. The display will then show a [1] alternating to [de]. This first function verifies that the control will address the requirements of the indirect water heater.

C. VISION 1 PROGRAM NAVIGATION

Next you will have to press [S3] to move through each function. To increase or decrease a value, you will need to press either [S1] or [S2] to change the default values. If there is no key action for 1 minute, the display returns to normal operation. Changes are effective immediately but not directly stored until the [S4] key is pressed down for 3 seconds then the new values are stored. Listed below are the varieties of functions the installer can program into the Vision I System.

NOTE: The heater cannot be programmed when there is a call for heat. See Table 12 in Part 13 to set outdoor reset curve.

START-UP PROCEDURES WITH VISION 1 OPTION		
DEFAULT FUNCTION	FUNCTION VALUE	DESCRIPTION
1	de	Not Applicable
2	149°F	Not Applicable
3	160°F	Maximum domestic delivery water temperature set point the installer will program for indirect water heater. (NOTE: Does not apply if used with mechanical control). Range: 95°F to 160°F.
4	36°F	Not Applicable
5	7°F	Allows the installer to change the differential in the indirect water heater. (Does not apply if used with mechanical control.) Range: 1°F to 18°F.
6	0 Min.	Allows the installer to change the indirect circulator post purge time once the sensor is satisfied. (NOTE: It is recommended that circulator post purge time be set no greater than 5 minutes). Range: 0 to 60 minutes.
7	68°F	Outdoor temperature that you wish the central heating should be disabled – (warm weather shutoff). Range: 41°F to 122°F.
*8	5°F	Changes the minimum outside design temperature. Range: -49°F to 32°F (See Table 12 to set outdoor reset curve.)
*9	180°F	Changes the design supply water temperature based on the minimum outside design temperature. Range: 77°F to 180°F.
*10	68°F	Changes the maximum outside design temperature for central heating. Range: 95°F to 32°F.
*11	95°F	Changes the design supply water temperature from the heater based on the maximum outside design temperature. Range: 32°F to 180°F.
12	68°F	Sets the lowest temperature on heater for central heating. Range: 32°F to 180°F.
13	0 Min.	Changes the central heating circulator post purge time once the thermostat is satisfied. Range: 0 to 10 minutes.
14	30 Min.	Sets the maximum run time for the indirect water heater and the minimum run time for central heating. Range: 0 to 60 minutes.
15	0	Bus address (0=zone master 1-8=cascade slave). (Not currently used.)
16	0	Interface Board Activation 0 = not active, 1 = active WARNING: Never change the default setting without the heater interface board installed.
17	0	Interface Board Function 0 = Building Management, 1 = Enables Tekmar Modulating Control. (Consult with Tekmar to assure the Tekmar Control is compatible.)

18	1	Step Modulation – Regulates the burner output in 6 steps in one-minute intervals. This reduces short cycling. 1 = on, 0 = off
19	180°	Indirect heater set point (flow) Temperature default = 119° to 180°
20	1	Not applicable

NOTE: The maximum water temperature leaving the heater is limited to 185°F.

Table 11 - *Central Heating Curve Function

Central heating demand is detected when the room thermostat closes. When an outside sensor is also connected, the supply temperature will depend on the factory default central heating curve.

To set your heat curve, you will have to set the following parameters:

1. Minimum outside design temperature: **Function 8**.

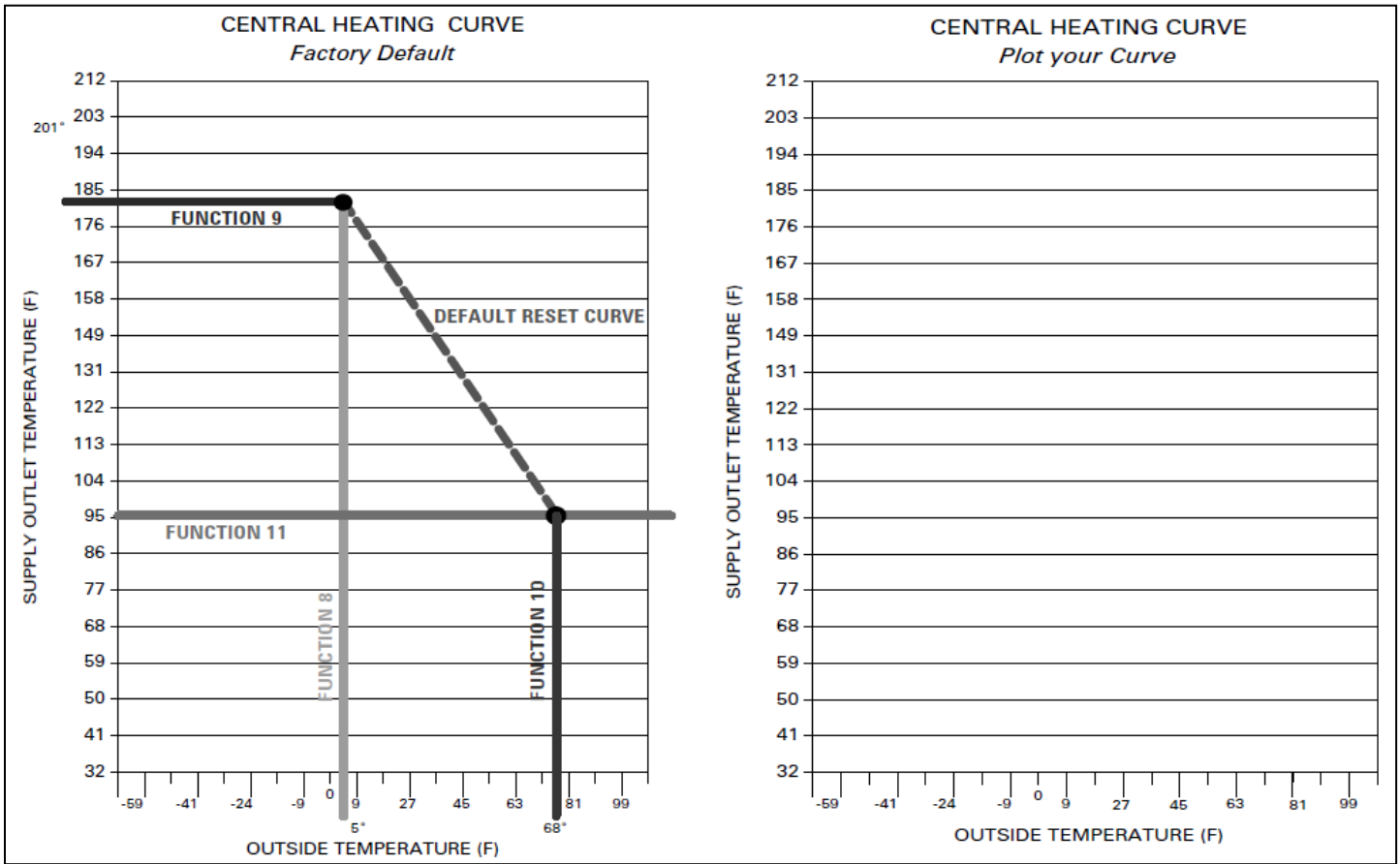

Table 12 – Central Heating Curve – Factory Default

2. Design supply water temperature at the minimum design outside temperature: **Function 9**.
3. Maximum outside design temperature: **Function 10**.
4. Design supply water temperature at the maximum outside temperature: **Function 11**.

NOTE: The homeowner can adjust the heat curve down by adjusting the central heating temperature to a lower setting.

PART 14 – TROUBLESHOOTING

A. ERROR CODE

An error code may occur in the installation of the heater. This condition may lead to a lock out condition of the controller, which will need to be manually reset through the [S4]. These temporary codes will help the installer correct the problem before going into a lock out condition, which will require a manual reset.

B. HEATER ERROR

1. When an error condition occurs the controller will display an error code on the display module.
2. These error codes and several suggested corrective actions are included in Table 14.
3. In the case of E00, E13, and E14 this error, if uncorrected, will go into a fault condition as described in Paragraph C (Heater Fault).

C. HEATER FAULT

1. When a fault condition occurs the controller will illuminate the red "fault" indication light and display a fault code in the format (Example: [F00]) on the display module.
2. Note the fault code and refer to Table 15 for an explanation of the fault code along with several suggestions for corrective actions.
3. Press the reset key to clear the fault and resume operation. Be sure to observe the operation of the unit to prevent a recurrence of the fault.

CONTROL PROGRAM REFERENCE CHART		
FUNCTION	DEFAULT SETTING	PROGRAMMED SETTING
1	de	No change allowed
2	149°F	No change allowed
3	160°F	
4	36°F	No change allowed
5	7°F	
6	0 Min.	
7	68°F	
8	5°F	
9	180°F	
10	68°F	
11	95°F	
12	68°F	
13	0 Min.	
14	30 Min.	
15	0	
16	0	
17	0	
18	1	
19	180°F	

Table 13

WARNING

When servicing or replacing any components of this heater be certain that:

- The gas is off.
- All electrical power is disconnected.

DANGER

When servicing or replacing parts that are in direct contact with heater water, be certain that:

- There is no pressure in the heater. (Pull the release on the relief valve. Do not rely on the pressure gauge reading.)
- The heater water is not hot.
- The electrical power is off.

WARNING

DO NOT USE THIS HEATER IF ANY PART HAS BEEN SUBMERGED IN WATER. Immediately call a qualified service technician. The heater **MUST BE** replaced if it has been submerged. Attempting to operate an heater that has been submerged could create numerous harmful conditions, such as a potential gas leakage causing a fire and/or explosion, or the release of mold, bacteria, or other harmful particulates into the air. Operating a previously submerged heater could result in property damage, severe personal injury, or death.

NOTE: Heater damage due to flood or submersion is considered an Act of God, and IS NOT covered under product warranty.

CAUTION

This heater has wire function labels on all internal wiring. Observe the position of each wire before removing it. Wiring errors may cause improper and dangerous operation. Verify proper operation after servicing.

CAUTION

If overheating occurs or the gas supply fails to shut off, do not turn off electrical power to the circulating pump. This may aggravate the problem and increase the likelihood of heater damage. Instead, shut off the gas supply to the heater at the gas service valve.

926 CONTROL BOARD ERROR CODES			
CODE	DESCRIPTION	DURATION	CORRECTIVE ACTION
FOU	Outdoor sensor is open, shorted, or outdoor temperature is below -40°F	Until Corrected	<ol style="list-style-type: none"> 1. Disconnect the outdoor sensor from the wiring and measure its resistance. Compare the measured resistance to the table in this manual to see if it corresponds to the temperature of the sensor. If the resistance does not agree with the sensor, replace the sensor. 2. If the resistance is OK, disconnect the sensor wiring from both the boiler and the sensor and check continuity using an ohmmeter. Repair or replace as necessary.
E03	The system sensor is open or shorted	Until Corrected	<ol style="list-style-type: none"> 1. Disconnect the system sensor from the wiring and measure its resistance. Compare the measured resistance to the table in this manual to see if it corresponds to the temperature of the sensor. If the resistance does not agree with the sensor, replace the sensor. 2. If the resistance is OK, disconnect the sensor wiring from both the boiler and the sensor and check continuity using an ohmmeter. Repair or replace as necessary.
E19	The line voltage frequency is out of range	Until Corrected	Inspect power wiring to boiler and repair as necessary. If connected to line voltage, notify the power company. If connected to an alternate power source such as generator or inverter, make sure the line voltage frequency supplied by the device is 60 Hz.
PRO	Water Pressure Switch is Open	Until Corrected	<ol style="list-style-type: none"> 1. Assure that the system pressure is above 10 psig. 2. Check for leaks in the system piping.
FLU	Blocked Vent Pressure Switch open, Condensate Cup Full, Condensate Cup not present	Until Corrected	<ol style="list-style-type: none"> 1. Check the flue vent to be sure it is not blocked or damaged. 2. Check the blocked vent pressure switch operation by applying a jumper. (If the switch is not functioning properly, replace it. 3. If the condensate cup is excessively full, check the condensate piping system for piping and proper drainage. Repair as necessary. If the condensate cup is not excessively full and is in place, remove the cup and check the operation of the float switch in the cup. The float should pivot freely in the cup and the back of the float should contact the stem of the switch when in the down position. 4. Reinstall the condensate cup. While doing so, check the operation of the cup-in-place switch. The switch should contact the protrusion on the plastic socket that the cup is secured into and trip when the cup is snapped into place. 5. Check to be sure that the 2 pin condensate cup connector is securely plugged into the socket on the bottom of the heater. 6. If FLU code is still present and the cause not found, check continuity of wiring from the flue switch to the condensate cup connector (pink wires) and from the condensate cup connector through the condensate float switch and condensate cup-in-place switch. These three devices are all wired in series with each other. Repair any wiring or replace defective components if necessary. <div style="background-color: black; color: white; padding: 5px; text-align: center;">  DANGER </div> <p>Do not "Jump Out" any of the devices in this circuit. These devices ensure product safety and must be in place and connected at all times of normal operation.</p>

Table 14

926 Control Board FAULT		
Code	Description	Remedy
F00	High temperature switch limit exceeded 194°F.	<ol style="list-style-type: none"> 1. Check circulation pump operation. 2. Assure that there is adequate flow through the heater by accessing the status menu and assuring that there is less than a 50°F rise from the return thermister to the supply thermister. 3. Check thermister reading on supply thermister. Replace switch if faulty.
F01	Vent temperature limit exceeded.	<ol style="list-style-type: none"> 1. Push the red reset button on the vent temperature limit switch. 2. Check module overheat switch. Disconnect the wires plugged into the switch and measure continuity across the switch. 3. Check the flue temperature during operation using a combustion analyzer. 4. Replace the vent limit switch if faulty. Replace module overheat switch if open.
F02	Interrupted or shorted supply (outlet) thermister.	<ol style="list-style-type: none"> 1. Check the electrical connection to the thermister on the outlet manifold. 2. If connection is okay, replace thermister.
F03	Interrupted or shorted return (inlet) thermister.	<ol style="list-style-type: none"> 1. Check the electrical connection to the thermister on the outlet manifold. 2. If connection is okay, replace thermister.
F05	Supply (outlet) temperature exceeds 230°F.	<ol style="list-style-type: none"> 1. Check circulation pump operation. 2. Assure that there is adequate flow through the heater by accessing the status menu and assuring that there is less than a 50°F rise from the return thermister to the supply thermister.
F06	Return (inlet) temperature exceeds 230°F.	<ol style="list-style-type: none"> 1. Check circulation pump operation. 2. Assure that there is adequate flow through the heater by accessing the status menu and assuring that there is less than a 50°F rise from the return thermister to the supply thermister.

F09	No flame detected – The heater will make three attempts at ignition before the control goes into this lockout condition. *See spark electrode detail.	<ol style="list-style-type: none"> 1. Watch the igniter through the observation window provided. 2. If there is no spark, check the spark electrode for the proper ¼" gap by holding two quarters together and sliding them through the gap. 3. Remove any corrosion from the spark electrode and flame rectifier probe. 4. If there is a spark but no flame, check the gas supply to the heater. 5. If there is a flame, check the flame sensor. 6. Check any flue blockage or condensate blocks.
F10	Loss of flame signal – The heater will relight 4 times before the control goes into this lockout condition. Will reset in 1 hour.	<ol style="list-style-type: none"> 1. Monitor the gas pressure to the unit while in operation. 2. Assure that the flame is stable when lit. 3. Check to see if the green light on the display module is out while the heater is running. 4. If the green light doesn't come on or goes off during operation check the flame signal on the status menu. 5. If the signal reads less than 1 microampere, clean the flame rectifier probe. 6. If the flame rectifier probe continues to read low, replace it.
F11	False flame signal – The heater will lock out if it senses a flame signal when there should be none present.	<ol style="list-style-type: none"> 1. Turn the gas off to the unit at the service valve. 2. If the flame signal is still present replace the igniter. 3. If the flame signal is not present after turning off the gas supply, check the gas valve electrical connection. 4. If there is no power to the gas valve, remove the valve and check for obstruction in the valve seat or replace the gas valve. 5. Turn the gas on at the service valve after corrective action is taken.
F13	Combustion fan speed out of tolerance – The appliance will lock out if it senses that the fan speed is not at 70% the expected speed for more than 60 seconds.	<ol style="list-style-type: none"> 1. Check the combustion fan wiring. 2. Replace the combustion fan. 3. Replace the control board.
PP	The control has been programmed by a technician or the factory. After programming, the control is left in a locked out mode.	Press the RESET key for at least 1 second to begin use of the control.
F31	Parameter Memory	Call factory for further assistance.

Table 15

Resistance Tables

OUTDOOR SENSOR (7250P-319)	
OUTSIDE TEMP. (°F)	RESISTANCE (ohms)
-22	171800
-13	129800
-4	98930
5	76020
14	58880
23	45950
32	36130
41	28600
50	22800
59	18300
68	14770
77	12000
86	9804
95	8054
104	6652
113	5522

Table 16

HEATER SENSOR (7250P-059)	INDIRECT SENSOR (7250P-325)
HEATER AND INDIRECT TEMPERATURE (°F)	RESISTANCE (ohms)
32	32550
41	25340
50	19870
59	15700
68	12490
77	10000
86	8059
95	6535
104	5330
113	4372
122	3605
131	2989
140	2490
149	2084
158	1753
167	1481
176	1256
185	1070
194	915
203	786
212	667

Table 17

PART 15 – MAINTENANCE

A. MAINTENANCE PROCEDURES

Periodic maintenance should be performed once a year by a qualified service technician to assure that all the equipment is in safe efficient operation. The owner can make necessary arrangements with a qualified heating contractor for periodic maintenance of the heater. Installer must also inform the owner that the lack of proper care and maintenance of the heater may result in a hazardous condition. The installer should discuss the contents of the User's Information Manual with the owner.

⚠ WARNING

BEFORE EACH HEATING SEASON a trained and qualified service technician should perform the inspections and maintenance procedures as identified in this manual. In addition, the maintenance and care of the heater outlined in this manual must be performed to assure maximum efficiency and reliability. Failure to do so could result in substantial property damage, serious personal injury, or death.

⚠ WARNING

The combustion chamber insulation in this product contains ceramic fiber material. Ceramic fibers can be converted to cristobalite in very high temperature applications. The International Agency for Research on Cancer (IARC) has concluded, "Crystalline silica inhaled in the form of quartz or cristobalite from occupational sources is carcinogenic to humans (Group 1)."

- Avoid breathing dust and contact with skin and eyes.
- Use NIOSH certified dust respirator (N95). This type of respirator is based on the OSHA requirements for cristobalite at the time this document was written. Other types of respirators may be needed depending on job site conditions. Current NIOSH recommendations can be found on the NIOSH website at <http://www.cdc.gov/niosh/homepage.html>. NIOSH approved respirators, manufacturers, and phone numbers are also listed on this website.
- Wear long-sleeved, loose fitting clothing, gloves, and eye protection.
- Apply enough water to the combustion chamber to prevent dust.
- Wash potentially contaminated clothes separately from other clothing. Rinse clothes washer thoroughly.

NIOSH stated First Aid.

- Eye: Irrigate immediately.
- Breathing: Fresh Air.

B. MAINTENANCE SCHEDULE FOR THE SERVICE TECHNICIAN

The following maintenance should be performed annually by a qualified service technician:

General

- Attend to any reported problems.
- Inspect the interior of the heater jacket area; clean and vacuum if necessary.
- Clean the condensate trap and fill with fresh water.
- Check for water, gas, flue and condensate leaks.
- Verify flue vent piping and air inlet piping are in good condition, properly supported, and tightly sealed.
- Check heater water pressure, piping and expansion tank.
- Check control settings.
- Check ignition electrode. Sand off any white oxide. Clean and reposition.
- Check ignition and ground wiring.
- Check all control wiring and connections.
- Check burner flame pattern (stable and uniform).

Additional Items if Combustion or Performance is Poor

- Clean heat exchanger and flue ways.
- Remove burner assembly and clean burner head using compressed air only.

Once the maintenance items are completed, review service with the owner.

C. COMBUSTION CHAMBER COIL CLEANING INSTRUCTIONS

*Before beginning this procedure, you must have on hand the following items:

- A nylon, stainless or brass brush (not steel)
- A liquid calcium and lime deposit remover
- Gloves, eye protection

1. Shut down the heater by using the following steps:

- a. Close the gas valve, shut down the unit and wait for the unit to be cool to the touch.
- b. Disconnect the condensate hose from the **outside** connection, (**not from the heater side**), so flow can be observed.
- c. Disconnect connections from the gas valve, spark electrode and flame rectification probe and combustion blower.
- d. Remove the (4) screws on the aluminum ½" NPT connector on the gas valve.
- e. Disconnect the wiring connected to the combustion blower motor.
- f. Remove the (4) 10MM nuts from the burner plate assembly to access the coils.
- g. Pull the entire burner plate assembly with blower still attached towards you, while removing or pushing aside any wiring to allow the removal of the assembly.

2. Using a spray bottle filled with calcium and lime deposit remover, spray liberally on the coils, making sure the solution penetrates and funnels down through the condensate hose. If the condensate hose is blocked, let the chemical penetrate for at least 15 minutes or until it drains.

3. Use the nylon, stainless or brass brush (do not use steel) and scrub coils to remove any buildup. Then vacuum the debris from the coils. **WARNING:** Follow above precautions.

4. Spray the coils with clear water, making sure to confine the spray to the area being cleaned (try to avoid getting the back ceramic wall of the unit wet). Flush the combustion chamber with fresh water. At this point, the heater should be ready to power back up.

Before powering up the heater follow the steps below:

- a. Re-install the burner assembly.
- b. Replace the (4) 10MM nuts to the burner plate.
- c. Re-connect all wiring connections.
- e. Replace the (4) screws on the aluminum ½" NPT connector on the gas valve. Turn the gas back on. (**IMPORTANT: CHECK FOR GAS LEAKS.**)
- f. Re-set thermostats (**IMPORTANT: MAKE SURE EXHAUST VENT IS NO LONGER BLOCKED!**)
- g. Turn the heater back on and observe condensate flow.
- h. Re-connect the condensate hose to the outside connection.

WARNING

Do not use solvents to clean any of the burner components. The components could be damaged, resulting in unreliable or unsafe operation. Failure to do so could result in death or serious injury.

D. MAINTENANCE SCHEDULE FOR THE OWNER

CAUTION

The following information provides detailed instruction for completing maintenance items. In addition to this maintenance, the heater should be serviced at the beginning of the heating season by a qualified service technician.

Periodically

- Check area around the unit.
 - Review Table 1 - Contaminant Table, p. 13. If contaminants are found:
 - Remove contaminants immediately from area.
 - If contaminants have been in the area for an extended period, call a qualified service technician to inspect the unit for possible acid corrosion damage.
 - If contaminants cannot be removed, immediately call a qualified service technician to re-pipe the combustion air inlet piping and locate the intake away from contaminated areas.
 - Do not store combustible materials, gasoline, or other flammable vapors or liquids near the unit. If found, remove these materials immediately.
- Check and remove any blockage from the combustion air inlet and ventilation openings.
 - If removing debris does not allow the unit to operate correctly, contact a qualified service technician to inspect the unit and the vent/combustion air system.
- Check the temperature and pressure gauge.
 - Ensure the pressure reading on the gauge does not exceed 25 psig. Higher pressure readings may indicate a problem with the expansion tank.
 - Ensure the temperature on the LED display panel does not exceed 180°F. Higher temperature readings may indicate a problem with the thermostat operating controls.
 - Contact a qualified service technician if problem persists.

Monthly

- Check vent piping.
 - Visually inspect the flue gas vent piping for any signs of blockage, leakage, or deterioration. Ensure that vent piping is properly supported as described in this manual. Notify a qualified service technician immediately if any problems are found.

WARNING

Failure to inspect the venting system and have it repaired by a qualified service technician can result in vent system failure, causing substantial property damage, severe personal injury, or death.

- Check combustion air inlet piping.
 - Visually inspect the air inlet piping for any signs of blockage. Inspect the entire length of the intake to ensure piping is intact and all joints are properly sealed and supported. Notify a qualified service technician if any problems are found.
- Check the pressure relief valve.
 - Visually inspect the primary pressure relief valve and discharge pipe for signs of weeping or leakage.
 - If the pressure relief valve often weeps, the expansion tank may not be operating properly. Immediately contact a qualified service technician to inspect the unit and system.

- Check the condensate drain system.
 - While the unit is running, check the discharge end of the condensate drain tubing. Ensure no clue gas is leaking from the condensate drain tubing by holding your fingers near the opening.
 - If you notice flue gas leaking from the opening, this indicates a dry condensate drain trap. Fill the condensate trap assembly with water. If problem persists regularly, contact a qualified service technician to inspect the unit and condensate line.
 - The service technician must ensure the condensate drain line is not blocked by pouring water through the plug port on the condensate drain assembly. The water should flow out of the end of the drain line. If water does not appear at the end of the drain line, the qualified service technician must clean the condensate line.
 - To fill the condensate drain assembly, remove the cup from the assembly. Slowly pour water into the cup until water appears at the end of the drain line. Stop filling and replace the cup.

⚠ WARNING

You must ensure that the condensate cup is securely fastened before restarting heater. Do a final check to ensure proper condensate flow.

Every 6 Months

- Check heater piping and gas supply piping for corrosion or signs of potential leakage.
 - Remove the heater cover and perform a gas leak inspection following Gas Valve Operating Instructions, p. 2 in this manual. If gas or odor leak is detected, immediately shut down the unit following To Turn Off Gas To Appliance procedures on p. 2. Call a qualified service technician.
 - Visually inspect for leaks around the internal heater water connections and around the heat exchanger. Visually inspect the external system piping, circulators, and system components and fittings. Immediately call a qualified service technician to repair any leaks.

⚠ WARNING

Have gas leaks fixed at once by a qualified service technician. Failure to comply could result in substantial property damage, severe personal injury, or death.

- Operate pressure relief valve.
 - Before proceeding, verify that the relief valve outlet has been piped to a safe place of discharge, avoiding any possibility of scalding from hot water.

⚠ WARNING

To avoid water damage or scalding due to relief valve operation, a discharge line must be connected to the valve outlet and directed to a safe place of disposal. This discharge line must be installed by a qualified service technician or heating/plumbing installer in accordance with this manual. The discharge line must be terminated so as to eliminate possibility of severe burns or property damage should the valve discharge.

- Read the temperature and pressure gauge to ensure the system is pressurized. Minimum is 10 psi. Maximum is 25 psi. Lift the relief valve top lever slightly, allowing water to relieve through the valve and discharge piping.
- If water flows freely, release the lever and allow the valve to seat. Watch the end of the relief valve discharge pipe to ensure that the valve does not weep after the line has had time to drain. If the valve weeps, lift the lever again to attempt to clean the valve seat. If the valve does not properly seat and continues to weep, contact a qualified service technician to inspect the valve and system.
- If water does not flow from the valve when you completely lift the lever, the valve or discharge line may be blocked. Immediately shut the unit down per instructions on p. 2 in this manual and call a qualified service technician to inspect the valve and system.

⚠ DANGER



⚠ DANGER Water temperature over 125 degrees F. can cause severe burns instantly, or death from scalds. Children, disabled, and elderly are at highest risk of being scalded. See instruction manual before setting temperature at water heater. Feel water before bathing or showering! Temperature limiting valves are available. See chart below showing temperature burn rate.



LP-171-G
03/03/22

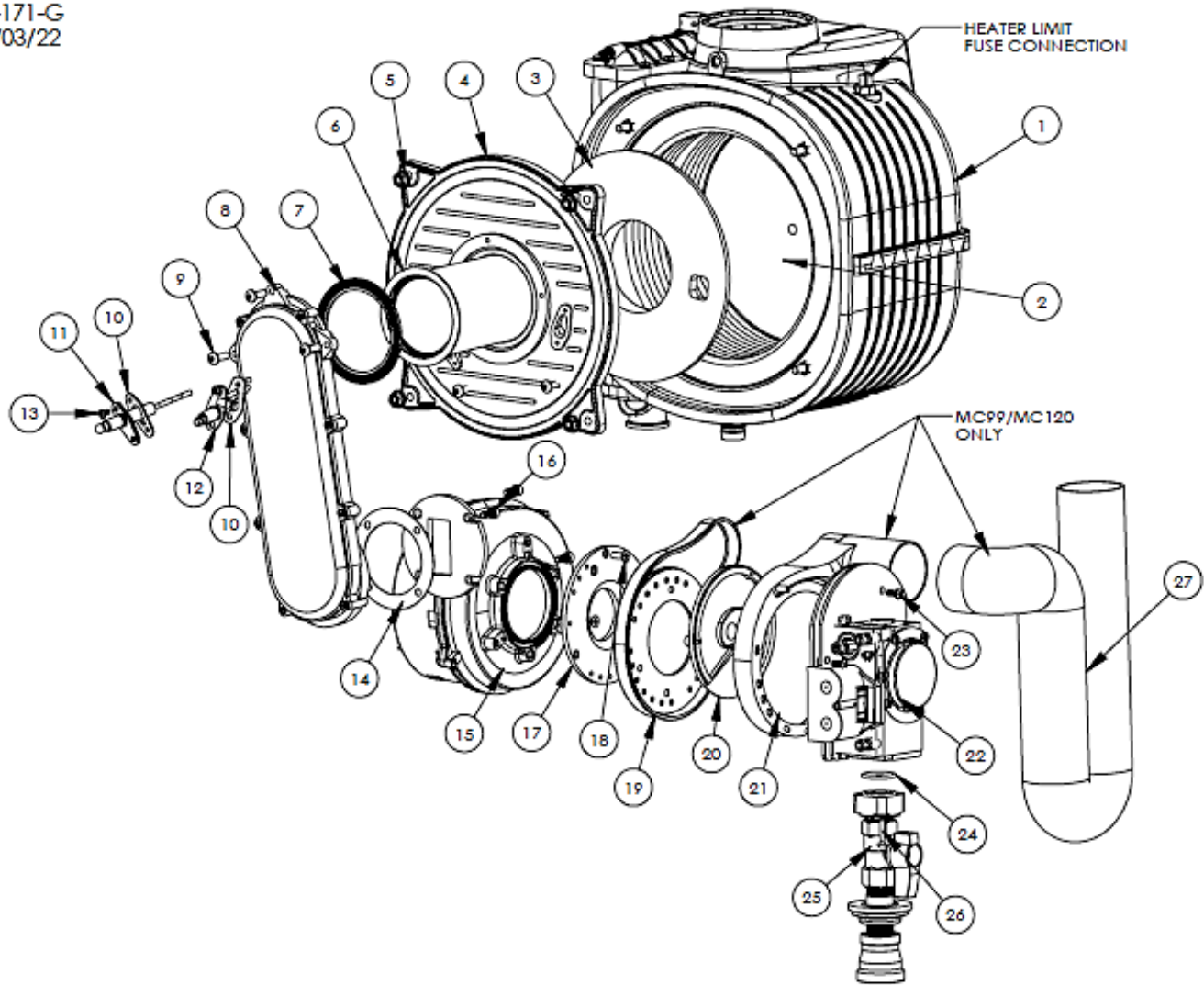

REPLACEMENT PARTS					
Item #	Description	Part #	Item #	Description	Part #
1	COMPOSITE MODULE	7500P-010 (MC50)	16	SCREWS M5 X 12MM (COMBUSTION BLOWER)	7250P-478
		7500P-012 (MC80)	17	GAS VALVE ADAPTER PLATE (w/SCREWS)	7250P-644
		7500P-014 (MC99/MC120)	18	SCREWS M4 X 12MM (GAS VALVE ADAPTER PLATE)	7500P-105
2	CERAMIC TARGET WALL	7250P-160	19	AIR INTAKE ADAPTER - BLOWER SIDE	7500P-184 (MC99/MC120)
3	BURNER DOOR CERAMIC REFRACTORY	7500P-076	20	GAS VALVE SWIRL PLATE	7500P-091 (MC50)
4	BURNER DOOR (w/NUTS)	7500P-078			7500P-092 (MC80)
5	NUTS - M6 (BURNER DOOR)	7500P-067			7500P-186 (MC99/MC120)
6	BURNER	7500P-015 (MC50)	21	AIR INTAKE ADAPTER - VALVE SIDE	7500P-185 (MC99/MC120)
		7500P-016 (MC80)	22	GAS VALVE (w/SWIRL PLATE, SCREWS)	7250P-448 (MC50)
		7500P-017 (MC99/MC120)			7250P-449 (MC80)
7	GASKET (BURNER)	7500P-074			7500P-180 (MC99/MC120)
8	AIR/GAS CHANNEL (w/TORX SCREWS)	7500P-079	23	SCREWS M4 X 16MM (GAS VALVE)	7250P-716 (MC50)
9	TORX SCREWS (AIR/GAS CHANNEL)	7500P-068		SCREWS M4 X 19MM (GAS VALVE)	7250P-717 (MC80)
10	GASKET (FLAME REC/SPARK ELECTRODE)	7250P-005		SCREWS M4 X 25MM (GAS VALVE)	7250P-718 (MC99/MC120)
11	FLAME RECTIFICATION PROBE (w/GASKET)	7500P-039	24	O-RING (GAS VALVE PIPING ASSY)	7500P-094
12	SPARK ELECTRODE (w/GASKET)	7350P-020	25	GAS VALVE PIPING ASSY (w/O-RING, SCREWS)	7500P-095
13	SCREWS M4 X 8MM (PROBE/ELECTRODE)	7250P-069	26	SCREWS M5 X 12MM (GAS VALVE PIPING ASSY)	7500P-099
14	GASKET (AIR CHANNEL TO COMBUSTION BLOWER)	7500P-075	27	2' FLEX HOSE - 25' LONG	7500P-189 (MC99/MC120)
15	COMBUSTION BLOWER (w/SCREWS)	7500P-195			

Figure 34

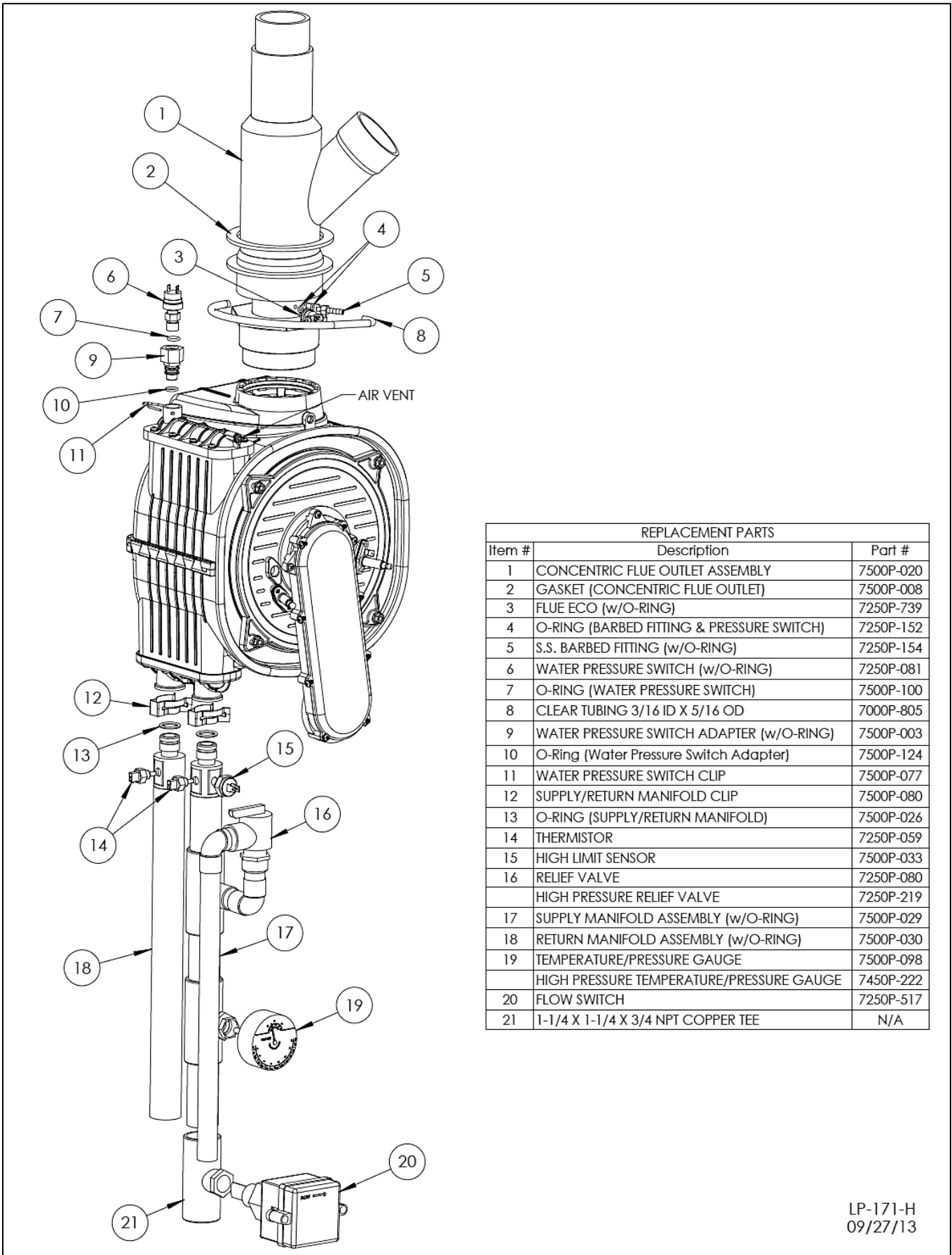

REPLACEMENT PARTS		
Item #	Description	Part #
1	CONCENTRIC FLUE OUTLET ASSEMBLY	7500P-020
2	GASKET (CONCENTRIC FLUE OUTLET)	7500P-008
3	FLUE ECO (w/O-RING)	7250P-739
4	O-RING (BARBED FITTING & PRESSURE SWITCH)	7250P-152
5	S.S. BARBED FITTING (w/O-RING)	7250P-154
6	WATER PRESSURE SWITCH (w/O-RING)	7250P-081
7	O-RING (WATER PRESSURE SWITCH)	7500P-100
8	CLEAR TUBING 3/16 ID X 5/16 OD	7000P-805
9	WATER PRESSURE SWITCH ADAPTER (w/O-RING)	7500P-003
10	O-Ring (Water Pressure Switch Adapter)	7500P-124
11	WATER PRESSURE SWITCH CLIP	7500P-077
12	SUPPLY/RETURN MANIFOLD CLIP	7500P-080
13	O-RING (SUPPLY/RETURN MANIFOLD)	7500P-026
14	THERMISTOR	7250P-059
15	HIGH LIMIT SENSOR	7500P-033
16	RELIEF VALVE	7250P-080
	HIGH PRESSURE RELIEF VALVE	7250P-219
17	SUPPLY MANIFOLD ASSEMBLY (w/O-RING)	7500P-029
18	RETURN MANIFOLD ASSEMBLY (w/O-RING)	7500P-030
19	TEMPERATURE/PRESSURE GAUGE	7500P-098
	HIGH PRESSURE TEMPERATURE/PRESSURE GAUGE	7450P-222
20	FLOW SWITCH	7250P-517
21	1-1/4 X 1-1/4 X 3/4 NPT COPPER TEE	N/A

LP-171-H
09/27/13

Figure 35

LP-171-J
09/30/13

Figure 36

Model	Control Board Part Number	Model	Control Board Part Number
MC-50	7500P-1100	MC-99	7500P-1102
MC-80	7500P-1101	MC-120	7500P-1103

Table 18 – MC Series Control Board Part Numbers

HEATER START-UP REPORT

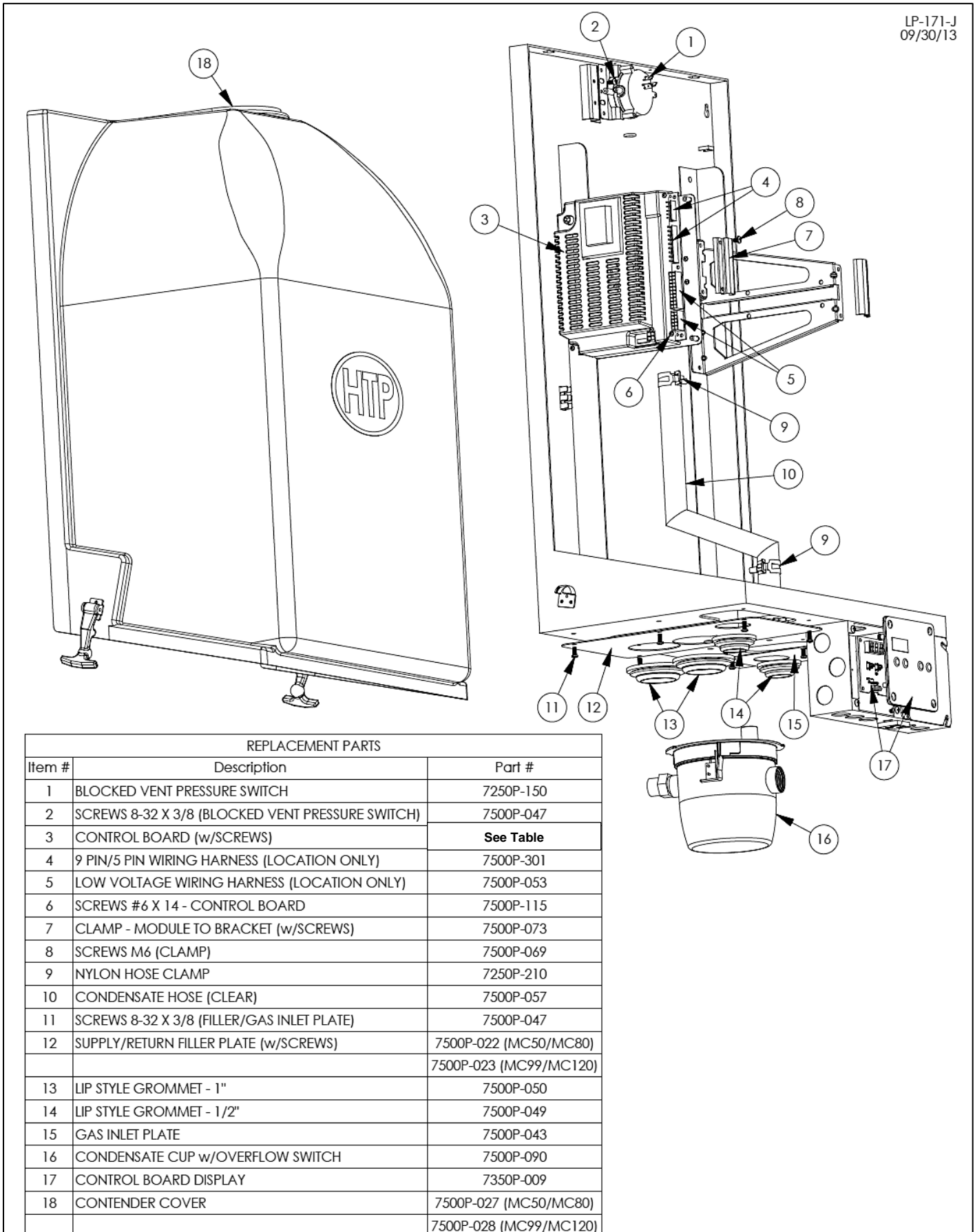
LIGHT OFF ACTIVITIES		DATE COMPLETED _____			
1) Fill the heating system	Check all piping and gas connections, verify all are tight				
	Pressurize system (12-15 PSI)	_____ PSI			
	Add water to prime condensate cup				
	What percentage of propylene glycol is installed in the system (0-50%)	_____ %			
	Verify near heater piping is properly supported				
2) Check gas pipe	Leak test using locally approved methods (consult jurisdictional code book)				
	Check incoming gas pressure (3.5" to 14" W.C.)	_____ in w.c.	Static		
	What is the "drop" on light off (No more than 1" W.C.)	_____ in w.c.	Dynamic		
3) Check combustion	Check and adjust (if necessary) carbon dioxide content	_____ % CO2	High Fire	_____ % CO2	Low Fire
	Check and adjust (if necessary) carbon monoxide content	_____ ppm CO	High Fire	_____ ppm CO	Low Fire
4) Verify system operation	Turn up thermostat to verify wiring connections				
5) Record ionization current	Check uA reading at d7 on the status menu (see start-up section)	_____ uA	High Fire	_____ uA	Low Fire
6) Record system settings	Record heating curve (with optional Vision One kit, record steps)	_____ *8	_____ *9	_____ *10	_____ *11
7) Indirect water heater	Verify safety and operation of the indirect water heater, record settings	_____ de	_____ dh		
8) Convert the heater	If necessary, convert the heater to the proper gas type				
	Locate the stickers in the appropriate locations on the heater				
	Verify combustion settings after gas conversion, Carbon Dioxide	_____ % CO2	High Fire	_____ % CO2	Low Fire
	Verify combustion settings after gas conversion, Carbon Monoxide	_____ ppm CO	High Fire	_____ ppm CO	Low Fire
	Mail in the conversion registration				
Notes:					

Table 19

MAINTENANCE REPORT

CAUTION

In unusually dirty or dusty conditions, care must be taken to keep heater cabinet door in place at all times. Failure to do so VOIDS WARRANTY!

WARNING

Allowing the heater to operate with a dirty combustion chamber will hurt operation. Failure to clean the heat exchanger as needed by the installation location could result in heater failure, property damage, personal injury, or death. Such product failures ARE NOT covered under warranty.

The heater requires minimal periodic maintenance under normal conditions. However, in unusually dirty or dusty conditions, periodic vacuuming of the cover to maintain visibility of the display and indicators is recommended.

Periodic maintenance should be performed once a year by a qualified service technician to assure that all the equipment is operating safely and efficiently. The owner should make necessary arrangements with a qualified heating contractor for periodic maintenance of the heater. Installer must also inform the owner that the lack of proper care and maintenance of the heater may result in a hazardous condition.

INSPECTION ACTIVITIES		DATE LAST COMPLETED			
		1 st YEAR	2 nd YEAR	3 rd YEAR	4 th YEAR*
PIPING					
Near heater piping	Check heater and system piping for any sign of leakage, make sure they are properly supported.				
Vent	Check condition of all vent pipes and joints.				
Gas	Check Gas piping, test for leaks and signs of aging. Make sure all pipes are properly supported.				
SYSTEM					
Visual	Do a full visual inspection of all system components.				
Functional	Test all functions of the system (Heat, Safeties)				
Temperatures	Verify safe settings on heater or Anti-Scald Valve				
Temperatures	Verify programmed temperature settings				
ELECTRICAL					
Connections	Check wire connections. Make sure they are tight.				
Smoke and CO detector	Verify devices are installed and working properly. Change batteries if necessary.				
Circuit Breakers	Check to see that the circuit breaker is clearly labeled. Exercise circuit breaker.				
CHAMBER/BURNER					
Combustion Chamber	Check burner tube and combustion chamber coils. Clean according to maintenance section of manual. Vacuum combustion chamber.				
Spark Electrode	Clean. Set gap at 1/4".				
Flame Probe	Clean. Check ionization in uA (d7 on status menu in Start-up Procedures). Record high fire and low fire.				
CONDENSATE					
Neutralizer	Check condensate neutralizer. Replace if necessary.				
Condensate hose	Disconnect condensate hose. Clean out dirt. Fill with water to level of outlet and re-install. (NOTE: Verify the flow of condensate, making sure that the hose is properly connected during final inspection.)				
GAS					
Pressure	Measure incoming gas pressure (3.5" to 14" W.C.)				
Pressure Drop	Measure drop in pressure on light off (no more than 1" W.C.)				
Check gas pipe for leaks	Check piping for leaks. Verify that all are properly supported.				
COMBUSTION					
CO/CO2 Levels	Check CO and CO2 levels in Exhaust (See Start-up Procedures for ranges). Record at high and low fire.				
SAFETIES					
ECO (Energy Cut Off)	Check continuity on Flue and Water ECO. Replace if corroded.				
Water Pressure Switch	Check operation and for signs of leakage. Replace if corroded.				
Thermistors	Check wiring. Verify through ohms reading.				
FINAL INSPECTION					
Check list	Verify that you have completed entire check list. WARNING: FAILURE TO DO SO COULD RESULT IN SERIOUS INJURY OR DEATH.				
Homeowner	Review what you have done with the homeowner.				

Table 20 - *Continue annual maintenance beyond the 4th year as required.

ADDITIONAL INSTALLATION REQUIREMENTS FOR THE COMMONWEALTH OF MASSACHUSETTS

In the Commonwealth of Massachusetts, the installer or service agent shall be a plumber or gas fitter licensed by the Commonwealth.

When installed in the Commonwealth of Massachusetts or where applicable state codes may apply; the unit shall be installed with a CO detector per the requirements listed below.

5.08: Modifications to NFPA-54, Chapter 10

(1) Revise NFPA-54 section 10.5.4.2 by adding a second exception as follows:

Existing chimneys shall be permitted to have their use continued when a gas conversion burner is installed, and shall be equipped with a manually reset device that will automatically shut off the gas to the burner in the event of a sustained back-draft.

(2) Revise 10.8.3 by adding the following additional requirements:

(a) For all side wall horizontally vented gas fueled equipment installed in every dwelling, building or structure used in whole or in part for residential purposes, including those owned or operated by the Commonwealth and where the side wall exhaust vent termination is less than seven (7) feet above finished grade in the area of the venting, including but not limited to decks and porches, the following requirements shall be satisfied:

1. INSTALLATION OF CARBON MONOXIDE DETECTORS. At the time of installation of the side wall horizontal vented gas fueled equipment, the installing plumber or gasfitter shall observe that a hard wired carbon monoxide detector with an alarm and battery back-up is installed on the floor level where the gas equipment is to be installed. In addition, the installing plumber or gasfitter shall observe that a battery operated or hard wired carbon monoxide detector with an alarm is installed on each additional level of the dwelling, building or structure served by the side wall horizontal vented gas fueled equipment. It shall be the responsibility of the property owner to secure the service of qualified licensed professionals for the installation of hard wired carbon monoxide detectors

a. In the event that the side wall horizontally vented gas fueled equipment is installed in a crawl space or an attic, the hard wired carbon monoxide detector with alarm and battery back-up may be installed on the next adjacent floor level.

b. In the event that the requirements of this subdivision cannot be met at the time of completion of installation, the owner shall have a period of thirty (30) days to comply with the above requirements; provided, however, that during said thirty (30) day period, a battery operated carbon monoxide detector with an alarm shall be installed.

2. APPROVED CARBON MONOXIDE DETECTORS. Each carbon monoxide detector as required in accordance with the above provisions shall comply with NFPA 720 and be ANSI/UL 2034 listed and IAS certified.

3. SIGNAGE. A metal or plastic identification plate shall be permanently mounted to the exterior of the building at a minimum height of eight (8) feet above grade directly in line with the exhaust vent terminal for the horizontally vented gas fueled heating appliance or equipment. The sign shall read, in print size no less than one-half (1/2) inch in size, "GAS VENT DIRECTLY BELOW, KEEP CLEAR OF ALL OBSTRUCTIONS".

4. INSPECTION. The state or local gas inspector of the side wall horizontally vented gas fueled equipment shall not approve the installation unless, upon inspection, the inspector observes carbon monoxide detectors and signage installed in accordance with the provisions of 248 CMR 5.08 (2)(a) 1 through 4.

(b) EXEMPTIONS: the following equipment is exempt from 248 CMR 5.08 (2)(a) 1 through 4:

1. The equipment listed in Chapter 10 entitled "Equipment Not Required to be Vented" in the most current edition of NFPA 54 as adopted by the Board; and
2. Product Approved side wall horizontally vented gas fueled equipment installed in a room or structure separate from the dwelling, building or structure used in whole or in part for residential purposes.

(c) MANUFACTURER REQUIREMENTS – GAS EQUIPMENT VENTING SYSTEM PROVIDED. When the manufacturer of Product Approved side wall horizontally vented gas equipment provides a venting system design or venting system components with the equipment, the instructions provided by the manufacturer for installation of the equipment and the venting system shall include:

1. Detailed instructions for the installation of the venting system design or the venting system components; and
2. A complete parts list for the venting system design or venting system.

(d) MANUFACTURER REQUIREMENTS – GAS EQUIPMENT VENTING SYSTEM NOT PROVIDED. When the manufacturer of a Product Approved side wall horizontally vented gas fueled equipment does not provide the parts for venting the flue gases, but identifies "special venting systems", the following requirements shall be satisfied by the manufacturer:

1. The referenced "special venting system" instructions shall be included with the appliance or equipment installation instructions; and
2. The "special venting systems" shall be Product Approved by the Board, and the instructions for that system shall include a parts list and detailed installation instructions.

(e) A copy of all installation instructions for all Product Approval side wall horizontally vented gas fueled equipment, all venting instructions, all parts lists for venting instructions, and/or all venting design instructions shall remain with the appliance or equipment at the completion of the installation.

HTP CUSTOMER INSTALLATION RECORD FORM

The following form should be completed by the installer for you to keep as a record of the installation in case of a warranty claim. After reading the important notes at the bottom of the page, please also sign this document.

Customer's Name:	
Installation Address:	
Date of Installation:	
Installer's Code/Name:	
Product Serial Number(s):	
Comments:	
Installer's Phone Number:	
Signed by Installer:	
Signed by Customer:	

IMPORTANT NOTES:

Customer: Please only sign after the installer has reviewed the installation, safety, proper operation and maintenance of the system. In the case that the system has any problems, please call the installer. If you are unable to make contact, please contact your HTP Sales Representative.

Distributor/Dealer: Please insert contact details.