

Little GIANT[®] Pump Company

Drainosaur
Waste Water
Removal System

WRS-6



Series Features

- Pump made of Cast Iron housing with protective epoxy coating for corrosion resistance
- Screened intake
- 3/10 HP motor with thermal overload protection
- Automatic diaphragm pressure switch enclosed in nylon housing with "on" level at 7" - 10" and "off" level at 1" - 4"
- Basin made of polypropylene, light weight, and corrosion resistant
- Basin designed with o-rings to provided a water tight seal
- Basin cover comes with a removable filter screen for easy cleaning
- Cover comes with 1-1/2" FNPT discharge, a 1-1/2" FNPT intake opening, and a 2" FNPT vent opening
- IAPMO listed basin
- Pre-assembled, ready to be installed

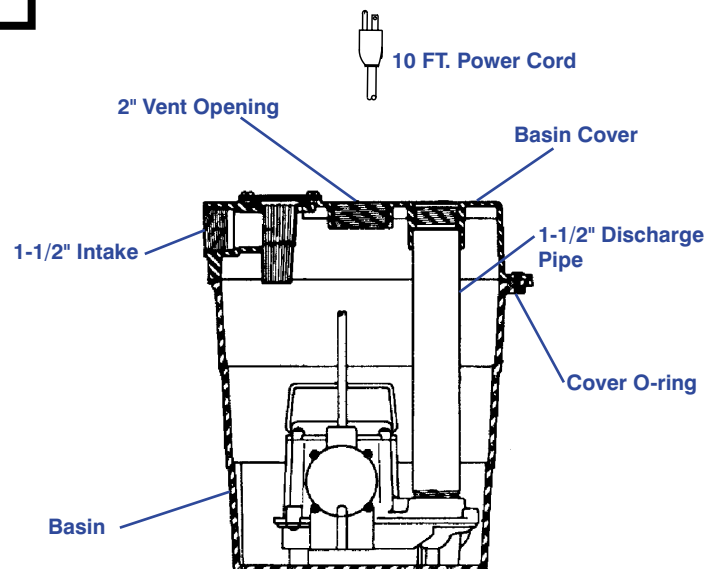

The "DRAINOSAUR" removes water from laundry trays, lavatory sinks, wet bar sinks, dehumidifiers, air conditioners (condensate), water softeners, etc. Installs above floor, no need to dig a sump. Unit is pre-assembled and ready to install.

Little Giant Pump Co.

WRS-6

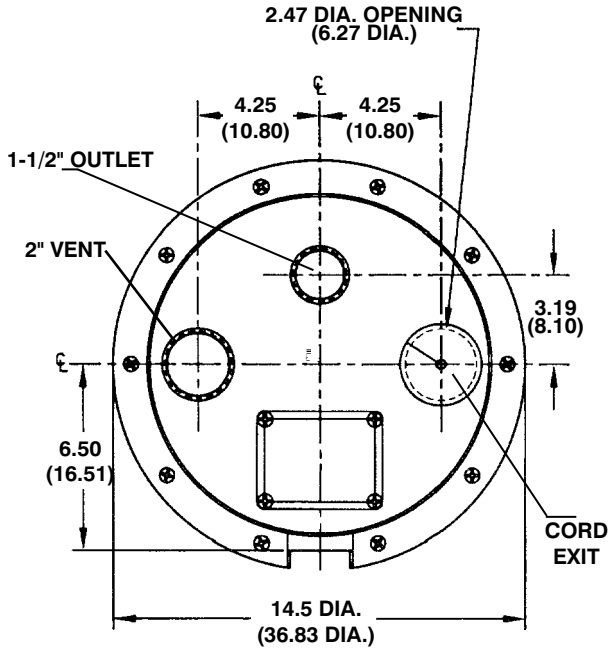

TOP VIEW OF COVER

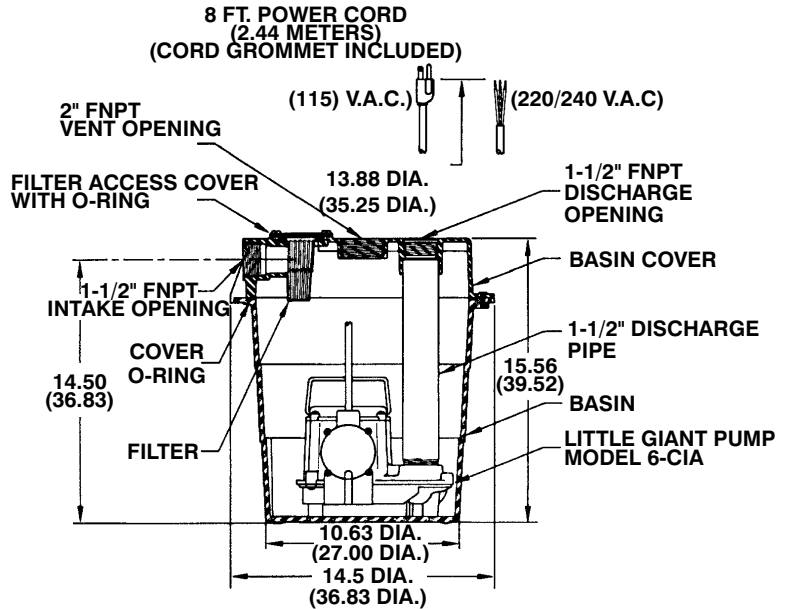

Specifications

MODEL NO.	ITEM NO.	DISCHARGE	LISTING	HP	VOLTS	HZ	RUNNING AMPS/WATTS	PERFORMANCE (GPM @ HEAD)				WEIGHT	DIMENSIONS W x H
								5'	10'	15'	SHUTOFF		
WRS-6	506055	1-1/2"	UL/CSA/IAPMO	3/10	115	60	9/720	45	29	12	18'	26 LBS	14.5 X 15.56
WRS-6	506056	1-1/2"	UL/CSA/IAPMO	3/10	230	50/60	4.5/720	45	29	12	18'	27 LBS	14.5 X 15.56

UL/CSA Listing for pump only

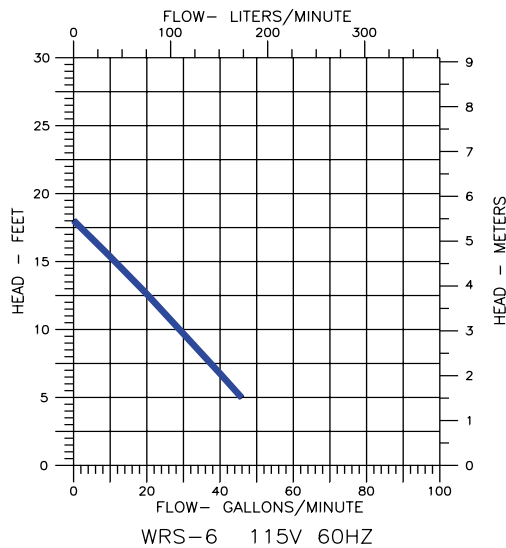

Pump Construction

Motor Housing	Epoxy-coated Cast Iron
Impeller Material	Nylon
Impeller Type	Non-Clog
Volute	Polypropylene
Power Cord	18/3 SJTW
Mechanical Shaft Seal	Nitrile w/Carbon & Ceramic Faces
Fasteners	Stainless Steel
Shaft	CRS
Bearings	Upper and Lower Sintered Sleeve Bearings

Basin Construction

Basin Cover	Polypropylene
Basin Fluid Capacity (Approx.)	5 Gallons
Discharge Size	1-1/2" FNPT
Intake Size	1-1/2" FNPT
Vent Size	2" FNPT



ISO 9001 CERTIFIED

Little Giant Pump Co.

PO Box 12010
Okla. City, OK 73157

Phone: 405.947.2511
Fax: 405.228.1550

www.LittleGiantPump.com

Form No. 993102 - 05/01