

14EH SERIES

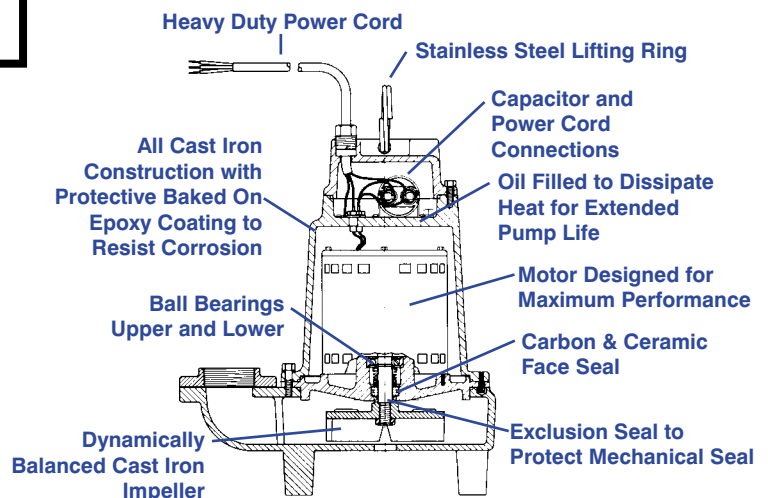

Features

- Handles liquids and solid waste materials up to 3/4 diameter.
- Cast iron pump housings with protective epoxy coating for corrosion and rust resistance
- Oil-filled motor housings for lifetime lubrication and rapid heat dissipation
- Stainless steel screws, bolts and lifting ring
- Mechanical seal (stainless steel spring, nitrite parts, carbon and ceramic faces) for long life and reliability.
- Secondary Exclusion Seal to help protect mechanical seal
- High Speed (3450 RPM) 1/2 HP, ball bearing motor and thermal overload protection for high head operation.
- Permanent split capacitor design.
- Capacitor and power cord connections isolated from oil filled motor housing for ease of field maintenance.
- Dynamically balanced two-vane non-clogging impeller with pump-out vanes to enhance pumping performance and efficiency.



For Residential, Commercial, Industrial and Agricultural use. Pumps feature 2" FNPT discharge with a lift of 50'. Heavy duty cast iron construction and stainless steel hardware.

Little Giant Pump Co.

14EH SERIES SUMP PUMP

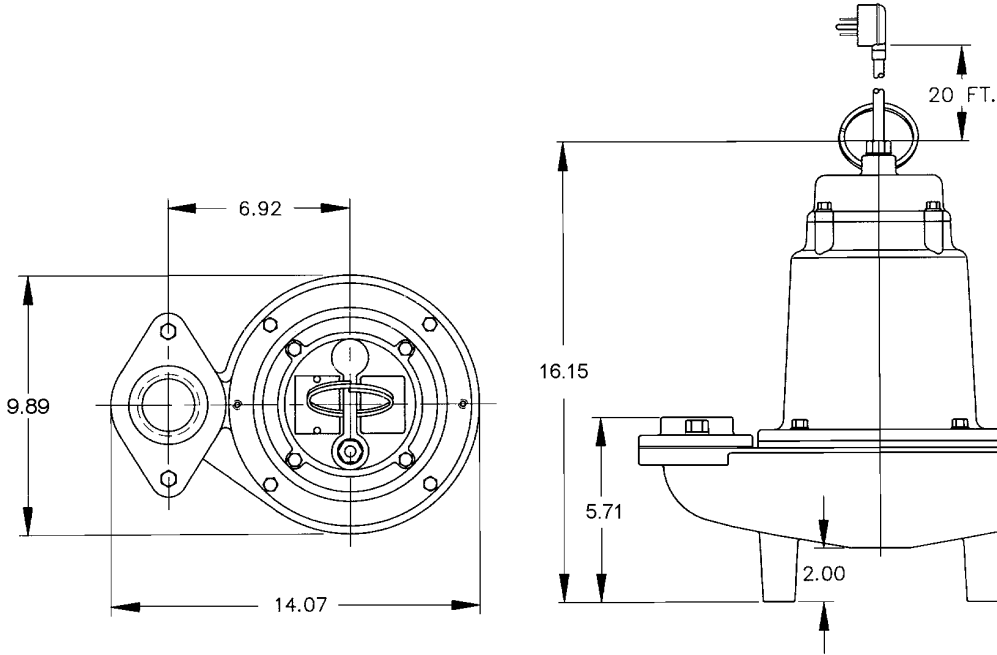

Specifications

MODEL NO.	ITEM NO.	DISCHARGE	SOLIDS Diameter	LISTING	HP	VOLTS	PHASE	HZ.	RPM	RUNNING AMPS/WATTS	SHUT OFF	P.S.I.	PWR CRD	WEIGHT (lbs.)
14EH-CIM	514220	2" FNPT	3/4"	UL/CSA	1/2	115	1	60	3450	12.5/1450	50'	21.6	20'	74
14EH-CIM	514221	2" FNPT	3/4"	UL	1/2	208/240	1	60	3450	5.7/1275	50'	21.6	20'	74

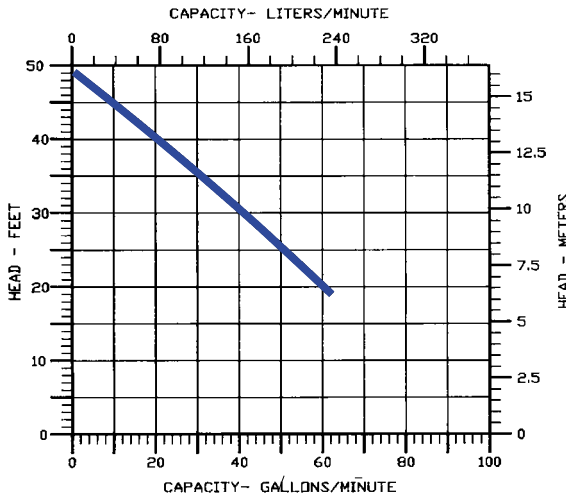

PUMP PERFORMANCE CURVE
115/60Hz

Construction

Motor Housing	Epoxy Coated Cast Iron
Impeller Material	Epoxy Coated Cast Iron
Impeller Type	Non-Clog
Volute	Epoxy Coated Cast Iron
Power Cord	SJTW-A
Mechanical Shaft Seal	Nitrile with carbon and ceramic faces
Fasteners	Stainless Steel
Shaft	Stainless Steel
Bearings	Upper and lower ball bearings



ISO 9001 CERTIFIED

Little Giant Pump Co.

PO Box 12010
Oklahoma City, OK 73157

Phone: 405.947.2511
Fax: 405.228.1550

www.LittleGiantPump.com

Form No. 994350 - 11/99