

Little GIANT[®]

Pump Company

5-ASP-FS SERIES



Features

- Automatic operation
- Epoxy coated die-cast aluminum housing
- Oil-filled motor
- 26.3' maximum lift
- 380 watts
- 1" FNPT discharge
- Thermal overload protection
- On level: 11"
- Off level: 3"
- Integral float switch
- For submersible use only

Construction

- Motor — 1/6 HP Oil Filled
- Intermittent Liquid Temp. up to — 120° F
- Intake — Screened
- Discharge — 1" FNPT
- Housing — Epoxy coated cast aluminum
- Cover — Epoxy coated cast aluminum
- Volute — Nylon
- Impeller — Nylon
- Shaft Seal — Viton[®]
- Screen — Nylon

Automatic submersible utility pump with oil-filled motor and epoxy coated cast aluminum housing. For commercial, industrial and home applications where liquid must be transferred or recirculated. Pumps down to 1/8". This 1200 GPH pump features a 1" FNPT discharge with garden hose adaptor, 26.3' shut-off head capability, and screened inlet.

Little Giant Pump Co.

5-ASP-FS SERIES

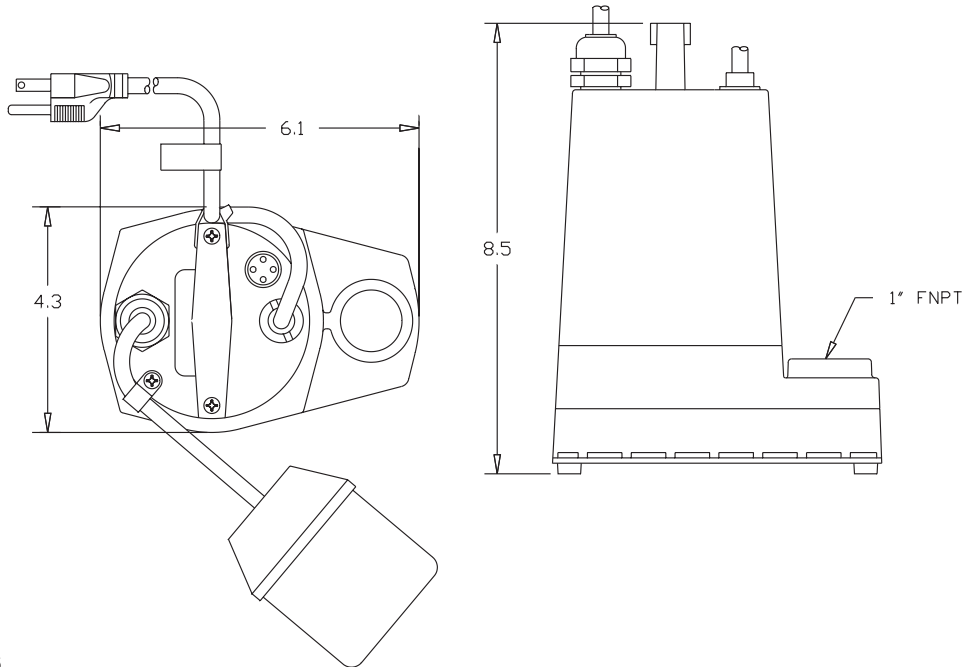

Specifications

Model No.	Item No.	Discharge	Intake	Listing(s)	HP	Volts	Hertz	Amps	Watts	Performance (GPH @ Head)					Shut Off		Pwr. Cord (ft)	Weight (Lbs.)
										1'	3'	5'	10'	20'	Feet	PSI		
5-ASP-FS	505400	1" FNPT	Screened	UL/CSA	1/6	115	60	5.0	380	1200	1170	1100	1000	520	26.3	11.4	10	9.00

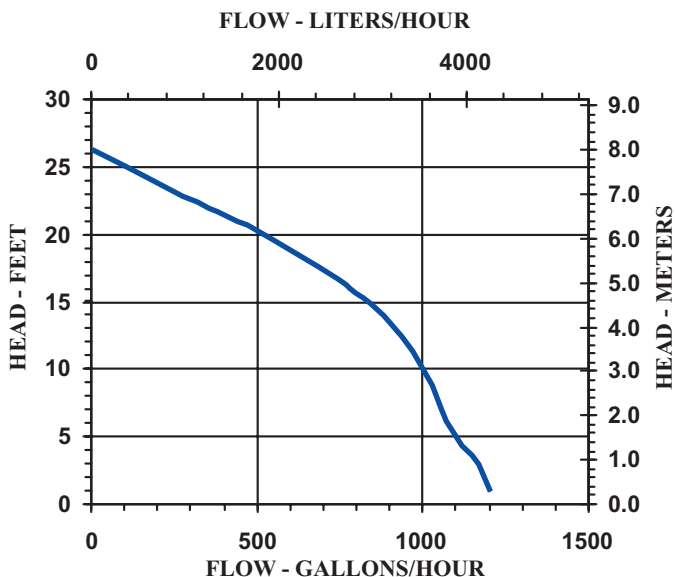

Replacement Parts

Volute	105200
Screen	105900
Impeller	105310
Handle	105911
Adapter (GH)	599030
Seal Ring	928024

Little Giant Pump Co.
 PO Box 12010
 Okla. City, OK 73157
 Phone: 405.947.2511
 Fax: 405.228.1550
www.LittleGiantPump.com