

Slant/Fin®

XL-2000™

OIL-FIRED WATER BOILERS/NO. 2 OIL

INSTALLATION AND OPERATING INSTRUCTIONS

SAFETY WARNING:

KEEP BOILER AREA CLEAR AND FREE FROM COMBUSTIBLE MATERIALS, GASOLINE AND OTHER FLAMMABLE VAPORS AND LIQUIDS. FAILURE TO ADHERE TO ABOVE SAFETY WARNING, MAY RESULT IN PERSONAL INJURY OR DEATH AND PROPERTY DAMAGE.

CONTENTS	PAGE
Ratings and Dimensions	2
Installation Requirements:	
Boiler Location	3
Clearances	3
Chimney Requirements	3
Air Supply and Venting	3,4
Controls and Accessories	5
Piping for Water Units	5
Installing Burner	5
Oil Supply Piping	5
Wiring the Boiler	5
Vent Piping and Draft Regulator	5
Operating Instructions:	
Precautions Before Starting	7
Start-up	7
Cleaning and Filling New Water Boiler	8
Care and Maintenance:	
Extended Shutdown	8
Freezing Protection	8
Oil Burner	9
General Maintenance	9
Wiring Diagrams	10
Burner Data	11,12



IMPORTANT: The installation of this equipment must conform to the requirements of the authority having jurisdiction or, in the absence of such requirements, to the Installation of Oil Burning Equipment, ANSI/NFPA 31, latest edition, and to the National Electrical Code ANSI/NFPA 70, latest edition. The installation must also conform to the additional requirements in this Slant/Fin Instruction Manual. Where there is any difference, the more stringent requirement shall govern.

In addition, where required by the authority having jurisdiction, the installation must conform to American Society of Mechanical Engineers Safety Code for Controls and Safety Devices for Automatically Fired Boilers, No. CSD-1, latest edition.

THIS MANUAL MUST BE LEFT WITH OWNER AND SHOULD BE HUNG ON OR ADJACENT TO THE BOILER FOR REFERENCE.

IMPORTANT: This boiler must be installed, serviced and repaired by a trained, experienced, service technician, licensed for the installation and servicing of oil burning hot water heating system equipment or otherwise qualified by the authorities having jurisdiction over the installation.



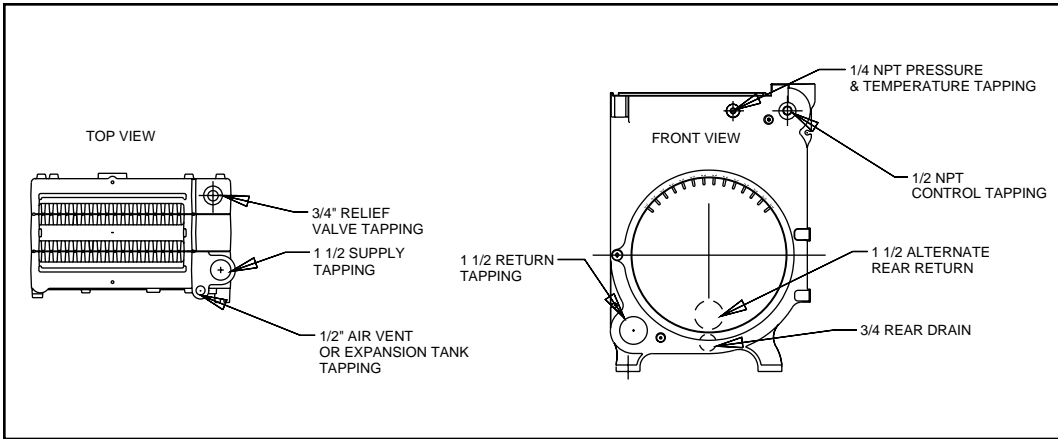

Figure 1.

Figure 2.

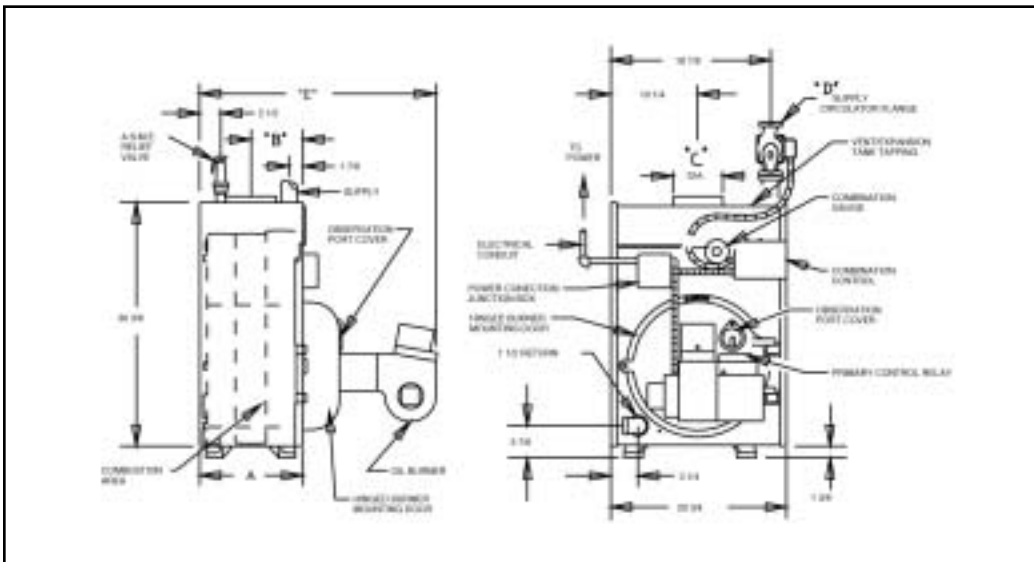

TABLE 1: Ratings and Dimensions

BOILER MODEL NO.	I=B=R BURNER CAPACITY OIL INPUT † §		D.O.E. HEATING CAPACITY MBH * WATER	I=B=R WATER NET RATING MBH *	I=B=R CHIMNEY SIZE		AFUE %	DIMENSIONS (inches) #				
	GPH	BTUH			NOM. RECT X HEIGHT ‡	I.D. ROUND X HEIGHT		BOILER LENGTH "A"	FRONT TO FLUE "B"	FLUE DIA.	CIRCULATOR SUPPLY FLANGE "D" NPT	APPROX. OVERALL LENGTH "E"
XL-20	0.65	91,000	78	68	8 x8x15	6 x 15	83.56	8 ¹¹ / ₁₆	4 ⁹ / ₁₆	6 ¶	1 ¹ / ₄	25 ³ / ₈
XL-30H	0.85	119,000	104	90	8 x8x15	6 x 15	86.00	12 ³ / ₁₆	6 ⁵ / ₁₆	6	1 ¹ / ₄	28 ⁷ / ₈
XL-30	1.00	140,000	121	105	8 x8x15	6 x 15	85.04	12 ³ / ₁₆	6 ⁵ / ₁₆	6	1 ¹ / ₄	28 ⁷ / ₈
	1.15	161,000	138	120	8 x8x15	6 x 15	84.12	12 ³ / ₁₆	6 ⁵ / ₁₆	6	1 ¹ / ₄	28 ⁷ / ₈
XL-40H	1.25	175,000	152	132	8 x8x15	7 x 15	86.00	15 ¹¹ / ₁₆	8 ¹ / ₁₆	7	1 ¹ / ₄	32 ³ / ₈
XL-40	1.35	189,000	162	141	8 x8x15	7 x 15	85.05	15 ¹¹ / ₁₆	8 ¹ / ₁₆	7	1 ¹ / ₄	32 ³ / ₈
	1.55	217,000	186	162	8 x8x15	7 x 15	84.38	15 ¹¹ / ₁₆	8 ¹ / ₁₆	7	1 ¹ / ₄	32 ³ / ₈
XL-50	1.80	252,000	217	189	8 x8x15	8 x 15	85.00	19 ³ / ₁₆	9 ¹³ / ₁₆	8	1 ¹ / ₂	35 ⁷ / ₈
	2.00	280,000	239	208	8 x8x15	8 x 15	84.19	19 ³ / ₁₆	9 ¹³ / ₁₆	8	1 ¹ / ₂	35 ⁷ / ₈

Standard working pressure 30 psi.

All boilers hydrostatically tested — A.S.M.E.

* For forced hot water heating systems where the boiler and all piping are located within the area to be heated, the boiler may be selected on the basis of D.O.E. capacity output. The net I=B=R output ratings shown are based on an allowance for piping and pickup of 1.15 (water) or 1.33 (steam). D.O.E. capacity output is divided by the allowance to obtain net rating. The Slant/Fin Technical Service department should be consulted before selecting a boiler for unusual piping and pickup requirements such as intermittent system operation, extensive piping, etc.

† Ratings apply to the use of light oil at 140,000 Btu per gallon and apply only when burner models listed on pages 11 and 12 of this manual are used, and

are properly adjusted to produce 13% CO₂.

‡ Nominal clay tile liner dimensions.

§ Water boiler models XL-30 and larger have two firing rates. The boiler is factory shipped at the lower firing rate. To obtain the higher firing rate, refer to the XL-2000 boiler installation instructions for the appropriate field adjustments. "H" models have only one firing rate.

¶ Oblong flue collar. Fits 6" dia. vent connectors.

All dimensions subject to normal manufacturing tolerance.

NOTE: All boilers under 300,000 Btu/h (87.9 kw) input are tested and rated for capacity under the U.S. Department of Energy (D.O.E.) Test Procedures for Boilers.

THE INSTALLATION INSTRUCTIONS IN THIS MANUAL ARE ABBREVIATED. SEE THE FRONT COVER OF THIS MANUAL FOR REFERENCES TO CODES AND STANDARDS.

BOILER LOCATION

Provide a level, solid foundation for the boiler. Location should be near the chimney so that the Flue Pipe Connector or Breeching to the chimney is short and direct.

- A. The foundation must be capable of supporting the weight of the boiler when filled with water:

Boiler Size	Approximate Total Weight of Boiler Assembly*, filled with water
XL-20	317
XL-30	405
XL-40	493
XL-50	581

* Includes burner, circulator and controls

- B. The XL-2000 Boiler has full wet base sections which surround fire-box for maximum heat absorption of burning fuel, and low floor temperature.
- C. If boiler is to be located over buried conduit containing electric wires or telephone cables, consult local codes or the National Board of Fire Underwriters for specific requirements.

MINIMUM CLEARANCE

Provide accessibility clearance of 24" from surfaces requiring servicing (top and front) and 18" on any side requiring passage. The boiler shall be installed with the following MINIMUM clearances from combustible materials:

- A. CHIMNEY CONNECTOR-18"
- B. BACK AND SIDES- 6" EXCEPT as limited by 18" clearance from chimney connector

NOTE: Except in closets and alcoves, clearances above in (A) and (B) may be reduced by providing forms of protection as specified in NFPA 31, latest edition.

CHIMNEY REQUIREMENTS (see NFPA 31, latest edition)

- A. The chimney must be constructed in accordance with all local applicable codes and the National Board of Fire Underwriters. See boiler models and rating table shown on page 2 for chimney sizes.
- B. Check chimney condition. Existing chimneys and stacks may have deteriorated; without repairs their use would be hazardous. Before connecting to an old chimney or stack:
 1. Clean it.
 2. Inspect it thoroughly.
 3. Remove obstructions.
 4. Replace worn sections of metal stacks.
 5. Seal bad masonry joints.
 6. Repair damaged lining.
- C. Where more than one appliance vents into a common chimney, the area of the common breeching should at least equal the area of the largest appliance flue plus 50% of the additional flue areas.
- D. Breeching area must not be reduced at connection into chimney. Breeching must be inserted into, but not beyond, inside of chimney liner.
- E. Chimney height shall extend at least 3 feet above where it passes through the roof of the building, and at least 2 feet above any ridge within 10 feet of the chimney.
- F. The use of a vent cap, where permitted by code, gives additional protection against adverse wind conditions and precipitation.
- G. Flue Connection: Connect flue pipe between top of boiler and chimney. Horizontal sections of flue pipe must be pitched upward to the chimney at least 1/4" per foot. Flue must be inserted into, but not extend beyond, the inside wall of the chimney flue. Install draft regulator in flue pipe, as shown in figure 3.

AIR SUPPLY AND VENTILATION (see NFPA 31, latest edition)

Sufficient air for combustion and ventilation in the boiler room must be provided. Failure to do this will result in poor combustion.

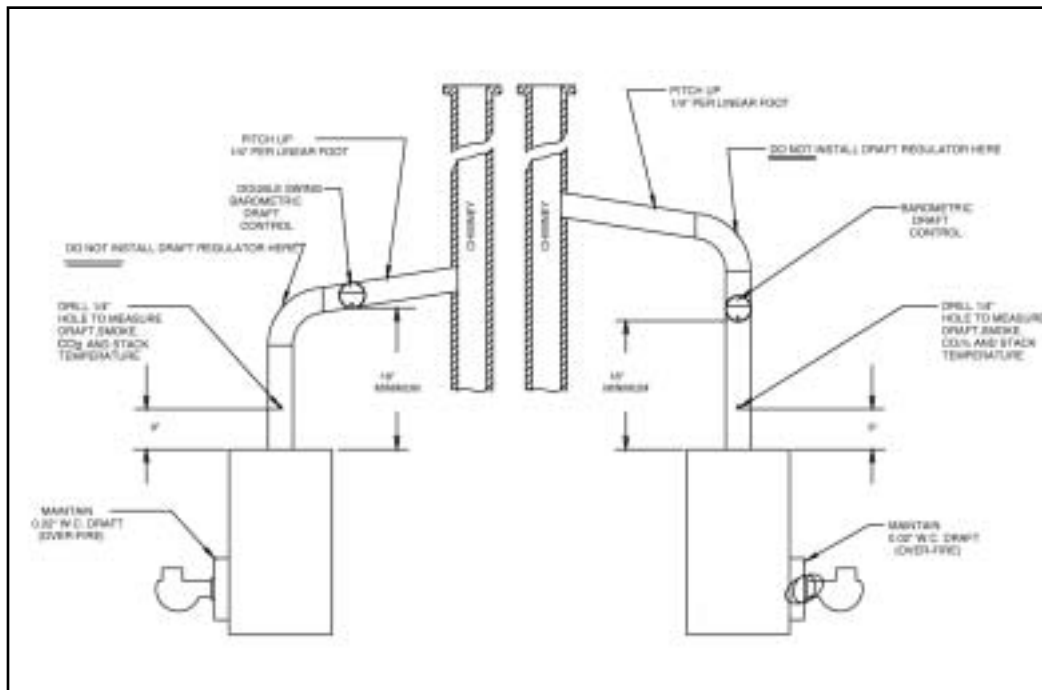

Figure 3.
Barometric Draft Regulator Location

tion, heavy sooting and health hazards. Any oil-fired boiler must have a steady draft* and an ample supply of combustion air at all times during firing. If air supply or chimney draft* is unreliable, CO₂ and overfire draft* will change unpredictably.

DO NOT vent this boiler to the same chimney flue used by a fireplace or coal or wood burning furnace or boiler. The draft* produced by solid fueled devices varies tremendously between high fire and low fire:

In modern, weather stripped, energy-saving buildings or older buildings which have been modified similarly, natural infiltration may not supply enough air for combustion, particularly if other fuel burning appliances, exhaust fans or draft inducers are competing for the same air supply. Fireplaces, other solid fuel burning appliances and exhaust fans consume great quantities of air; if air supply is not ample, such an appliance

* Draft is negative or suction pressure

will create a downdraft in the oil-fired boiler flue. This can create a hazardous condition. Flue gases can be sucked out of the chimney through the vent regulator into the living space. DO NOT operate this boiler and a solid fuel burning appliance at the same time, unless the solid fuel burner is provided with its own outside air supply.

See Table 2, "Provisions for Combustion and Ventilation Air Supply" for determining need and method of providing air for combustion and ventilation.

If fly screen must be used over air supply openings, areas calculated should be doubled; the screen should be inspected and cleaned frequently to maintain free air flow.

Protect air openings against closure by snow, debris, etc. Openings such as doors or windows, if used, must be locked open.

TABLE 2: Provisions for Combustion and Ventilation Air Supply. See NFPA 31, latest edition for more detailed information.

	Boiler Location	Air Supply	Action Required
2.1	Unconfined space	Is there sufficient air for combustion by natural infiltration (see NOTE (1), "Test..." below)?	NONE
2.2	Unconfined space	If there is NOT sufficient air for combustion by natural infiltration due to tight construction or other conditions, then it REQUIRES AIR FROM OUTDOORS. SEE "ACTION REQUIRED" column at right. See Notes (1) and (2) below.	Provide air from outdoors directly through a permanent outside wall opening or openings with a free open area of not less than 1 sq. in. per 4000 Btu/hr of TOTAL input of ALL fuel burning appliances in the building. See Note (1) and (3).
2.3	Confined space	If there is sufficient air for combustion from within building but it comes from outside of the confined space, see "ACTION REQUIRED" column at right. See Note (1) below.	The confined space shall be provided with two permanent air openings, one near the top of the enclosure and one near the bottom. EACH opening shall have a free air opening of not less than 1 sq. in. per 1000 Btu/hr. of TOTAL input of ALL fuel burning appliances within the enclosure. The two openings shall freely communicate with the interior areas of the building which in turn would have to have adequate infiltration of air from outdoors. See Notes (1, 3) and Figure 3a.
2.4	Confined space	If there is NOT sufficient air for combustion due to tight construction or other conditions it REQUIRES AIR FROM OUTDOORS. SEE "ACTION REQUIRED" column at right. See NOTE (2) below.	(a) Air from the outdoors shall be provided to the confined space by two permanent openings, one in or near the top of the enclosure space and one in or near the bottom. The openings shall communicate directly, or by means of ducts, with outdoors or to such spaces (crawl or attic) that freely communicate with outdoors (See figures 3b, 3c and 3d). (b) Where directly communicating with outdoors or by means of vertical ducts, each opening shall have a free area of not less than 1 sq. in. per 4,000 Btu/hr. (35 sq. in. per gal. per hr.) of total input rating of all appliances in the enclosure. If horizontal ducts are used, each opening shall have a free area of not less than 1 sq. in. per 2,000 Btu/hr. (70 sq. in. per gal. per hr.) of total input of all appliances in the confined space. See Figures 3b, 3c and 3d.

(1) Test for sufficient air for combustion by infiltration by running this boiler for 30 minutes under all of the following conditions and at the same time: a) all doors, windows and other like openings must be closed, b) all fuel burning appliances should be FIRING, c) all exhaust fans and clothes dryers turned ON. At the above conditions the CO₂, smoke and draft readings must be normal. (CO₂ between 11% and 13%, smoke between ZERO and a TRACE, draft between .02" W.C. and .04" W.C. negative pressure.)

(2) Aside from tight construction, some of the conditions that steal air for combustion from a boiler are other fuel burning appliances, exhaust fans and clothes dryers.
(3) Generally, louvers made of wood have a free open area of 20% and those made of metal have a 60% to 70% free open area. Screens also reduce the open area of the louvers.

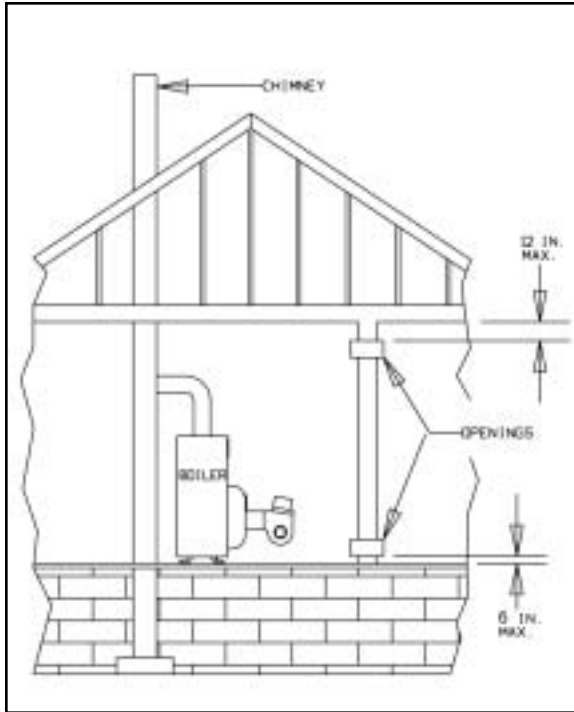

Figure 3a.
Appliances located in confined spaces. Air from inside the building. See Table 2 (2.3).

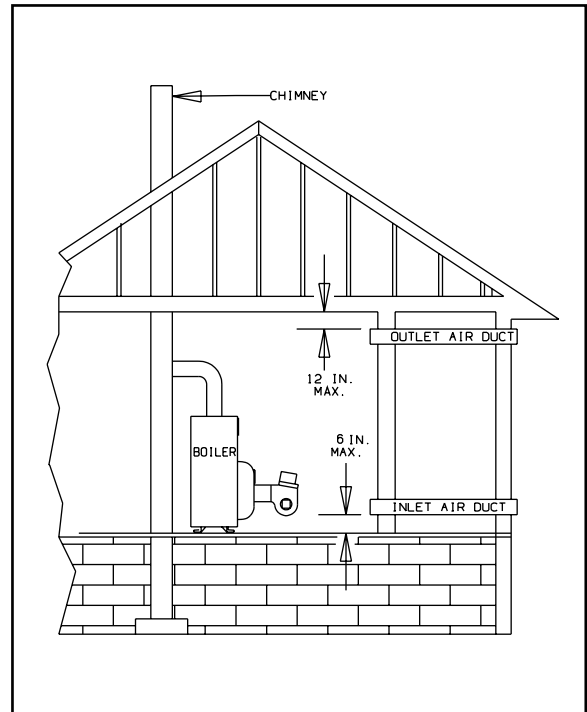

Figure 3b.
Appliances located in confined spaces. Air from outdoors. See Table 2 (2.4).

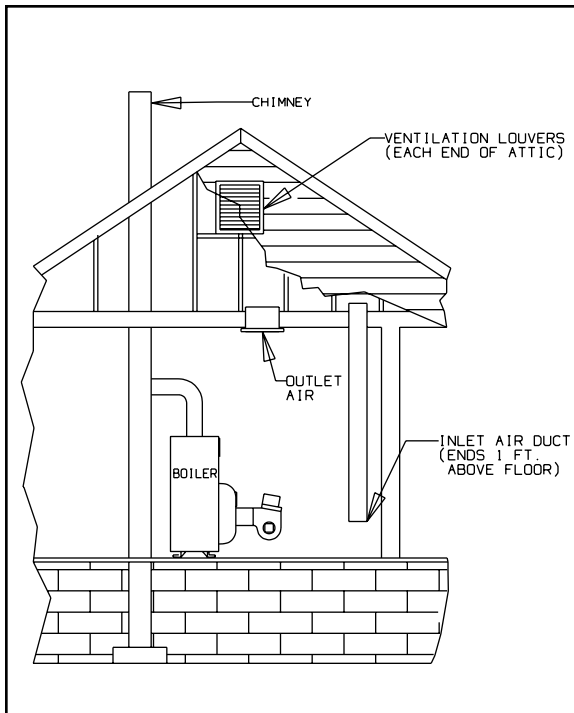

Figure 3c.
Appliances located in confined spaces. Air from outdoors through ventilated attic. See Table 2 (2.4).

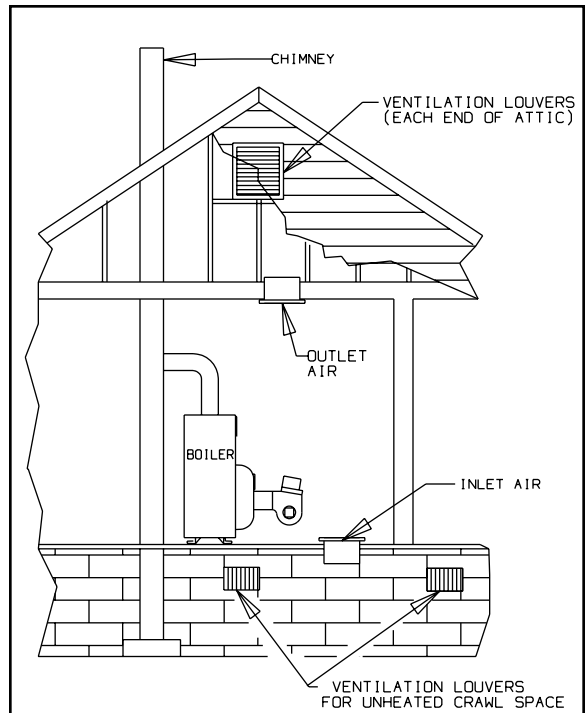

Figure 3d.
Appliances located in confined spaces. All air from outdoors through ventilated crawl space and outlet air to ventilated attic. See Table 2 (2.4).

The opening size recommendation just given is for guidance only. It is the installer's responsibility to provide air for combustion and ventilation to all appliances, under all operating conditions, for each installation. See NFPA 31, latest edition for more specific details.

INSTALLING CONTROLS AND ACCESSORIES ON BOILER UNITS

Notes: Jacket must be installed on boiler units prior to installation of trim.

WATER BOILER TRIM, see page 2, figures 1 and 2 for tapping locations.

WATER PIPING FOR HOT WATER HEATING BOILERS

NOTE: On knocked-down boiler only, jacket may be installed after supply piping connection, but must be installed prior to adding trim and piping returns and drain valve.

I. CIRCULATING SYSTEM

- A. **FORCED CIRCULATION** hot water heating system: Use the top tapping as supply tapping, and use the front or rear bottom tappings for the return.
- B. A **FLOW CONTROL VALVE** will prevent gravity circulation and is required when an external tankless heater, an indirect water heater or multiple circulators are installed.

II. AIR CONTROL SYSTEMS

- A. **DIAPHRAGM-TYPE COMPRESSION TANKS** are used to control system pressure in an **AIR ELIMINATING SYSTEM**: an automatic air vent is used to REMOVE air from the system water. (See figures 5 and 6)
If system pressure needs further control, add an additional tank or install a larger capacity tank.
The automatic air vent should be installed in the top of

the boiler, as in figures 5 and 6 and at radiation high points (see "C").

- B. **CONVENTIONAL COMPRESSION TANKS** (non-diaphragm type) are used to control system pressure in an **AIR COLLECTING SYSTEM**. Within the system, after initial start-up and venting, air is collected in the tank and acts in contact with the water to control pressure (see dashed area in figure 5 and paragraph "E"). Air is not vented from this system except at radiation high points (see "C").

If system pressure needs further control, add another tank in parallel with the original tank or install a large capacity tank. Locate the tank at the inlet end of the pump near the boiler. (See figure 5)

- C. **HOT WATER RADIATION VENTING** - Manual air vents should be installed at the top of all "drops" (where piping goes downward). Air must be vented or purged from all zone lines to permit proper system heating.
- D. **PUMP LOCATION** - Locating low-head pump(s) on return to boiler is only acceptable in residences of one or two stories. (See figure 6) The pump location shown in figure 5 is required in large, multi-story building installations, especially when high-head pumps are used and is also recommended for all applications.
- E. A conventional compression tank may be connected directly to the 1/2" tapping on the boiler (see "Alternate Compression Tank", figure 5).

IMPORTANT: Hot water heating systems containing high water volume, such as would occur with cast iron radiation, require special care with air elimination.

The circulator pump should be located on the boiler supply pipe and the expansion tank and air scoop should be located near the pump suction. (as shown in figures 5 and 6) For alternate circulator pump location on return for low-head pumps and one or two story buildings ONLY (see figure 6).

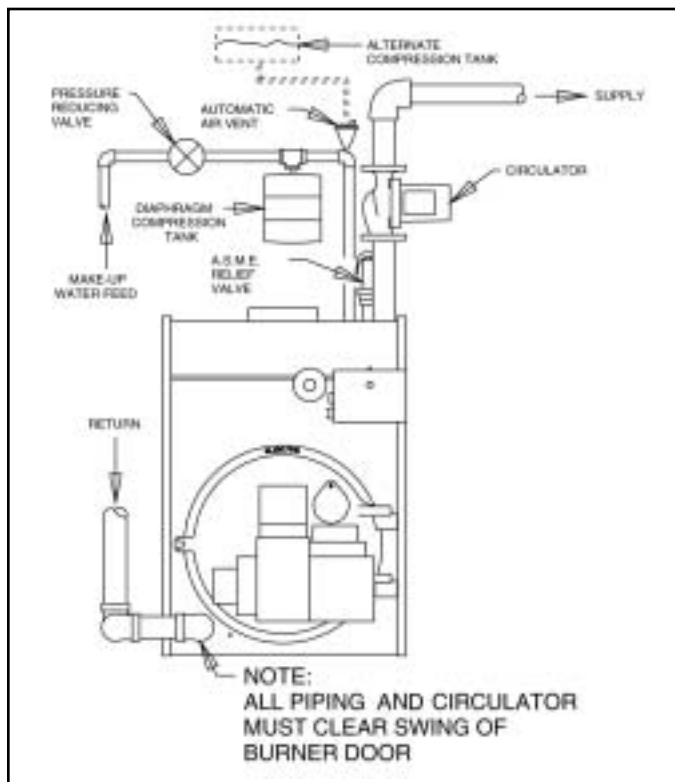

Figure 5. Air Eliminating System or Alternating Collecting System

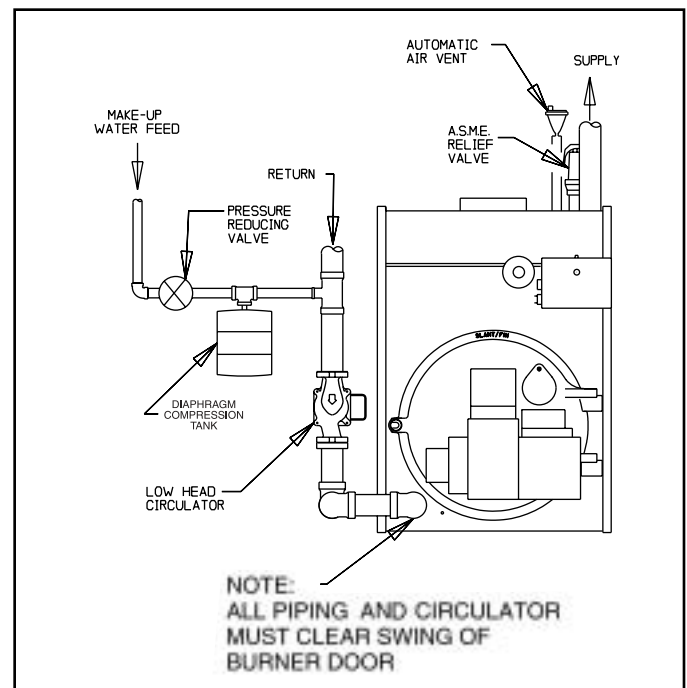

Figure 6. Alternate Air Eliminating System

DOMESTIC HOT WATER

For Indirect-fired storage water heater application, see Slant/Fin publication WH-10, Sizing Guide WH-SG and Installation manual WH-40. The installation manual includes several control systems and relay centers for space and domestic water heating in addition to plumbing.

INSTALLING THE BURNER

See Burner Data, pages 11 and 12, and Burner Manual supplied with burner. If burner is not mounted as received, mount to boiler, placing flange over mounting studs. Use gasket between flange and boiler. Distance between flange and nose of burner must be as shown on pages 11 and 12. Check to see that nozzle and settings are as given in burner data tables, pages 11 and 12.

OIL SUPPLY PIPING

Install the oil tank or tanks and piping from tank to burner. Follow local codes and practices, INSTALLATION OF OIL BURNING EQUIPMENT, NFPA 31, latest edition, and the instruction sheet attached to the oil burner pump. A one-pipe system should be used for gravity-fed fuel systems and for lift systems, where the total lift is less than 8 feet. Where the total lift is greater than 8 feet, a two-pipe system must be used. In some instances, local codes may require a two-pipe system for below grade fuel oil tanks. Be sure to set up the fuel oil pump for the piping system used; follow the instructions attached to the pump. Be sure to include a good quality, low pressure drop fuel oil filter in the supply line from the tank. This is necessary, especially at low fuel oil flow rates (small nozzle sizes), to prevent nozzle plugging. Fuel oil shutoff valves should be installed at the burner on the supply (and return if two-pipe) to facilitate servicing. See Slant/Fin publication on one-pipe and two-pipe fuel oil systems.

WIRING THE BOILER

(see National Electric Code ANSI/NFPA 70-latest edition)

- The wiring diagrams for the burner and boiler may be found on page 10.
- 24 volt control wiring should be approved Safety Circuit wire, protected as needed.
- Power supply wiring to the burner must be 14 gauge, as required, and should have a properly fused disconnect switch. 120 volt wiring to pumps and safety controls must also be 14 gauge. Wire must be enclosed in approved conduit.
- The wires supplying power to the burner MUST go through the quick disconnect plugs provided with the boiler.
- All wiring must be installed in compliance with the National Electric Code, or any local or insurance codes having jurisdiction.

VENT PIPING AND DRAFT REGULATOR

(see NFPA 31, latest edition)

- Vent connectors must be the same diameter as the boiler flue collar. (See page 2)
- Vent pipes and breeching must be pitched upward a minimum of 1/4" per foot.
- Connect vent pipe to the chimney using as few elbows as possible and as short as possible within NFPA 31 or authority.
- Horizontal vent connector into the chimney should not be inserted beyond the inside wall of the chimney.
- Install barometric draft regulator on horizontal breeching,

near chimney, with hinge horizontal and face vertical conditions permitting as in Figure 3a. See Figure 3b as a second choice. See manufacturer's instructions packed in carton with barometric draft regulator.

- If two or more appliances are used on the same chimney, see CHIMNEY, page 3.
- Make up all joints with minimum air leaks, secure with sheet metal screws.

PRECAUTIONS BEFORE STARTING OIL BURNER

Make a positive check of A through F before starting burner:

- Boiler and system are full of water. All air is vented from system. See below.
- All wiring is completed. See page 10.
- Oil supply is connected to the burner; nozzle is installed correctly; oil valve is open at tank.
- Main cast iron door on which burner is mounted is bolted shut and fiberglass rope seal is making good contact.
- Smokepipe is connected to chimney.
- All combustible materials are cleared away.
- Combustion air supply is provided. See page 3.
- Burner settings are adjusted as per pages 7, 8, 11 and 12 and as shown on boiler jacket.

WARNING: NEVER OPERATE any natural draft* boiler (XL-2000 boiler is a natural draft boiler) with zero draft or overfire pressure: early failure of the burner, nozzle and chamber is inevitable if you do. Use a draft gauge, and make sure that overfire draft* is .02" to .04", during all operating conditions.

* Draft is negative or suction pressure.

START-UP (COMBUSTION TEST INSTRUMENTS MUST BE USED)

- Make sure the boiler is installed and wired properly and is full of water.
- The observation port cover is mounted on the hinged burner mounting door (see figure 2 on page 2). NEVER touch the port cover or any surrounding surfaces with hands. They may be HOT. Use tools. Loosen the screw that fastens the observation port cover, swing the cover open and tighten the screw. See the burner instructions for bleeding air, etc. Step away from the boiler and start the oil burner.
- IMMEDIATELY, set burner air bands to obtain a bright fire without smoke or oil stain. Set the DRAFT REGULATOR to obtain .02" overfire draft*. Take draft reading through slot in observation door after first closing the observation door.
- Tighten the observation door screw. Allow the burner to fire for at least one hour total firing time, to bake out the volatile binders in the combustion chamber before taking final combustion readings.
- By alternate adjustment of the barometric draft regulator, the burner air regulation and head regulation devices (whichever apply), set for a zero to a trace of smoke and 12% CO₂. Then open the air bands or shutter (whichever apply) an additional 1/8". This should result in zero smoke with NO raw oil on the smoke paper and a smooth light-off. DO NOT ATTEMPT TO SET FIRE BY EYE. Flame retention burners may appear efficient and smoke free from an inefficient 7% up to an overly high 14% CO₂. However, a very low CO₂ can also result in poor ignition and raw (unburned) oil entering the fire box. At very high CO₂, any slight decrease in air flow for any reason will cause incomplete combustion, with high

- smoke and dry soot formation in the fire box.
- F. If smoke reading is satisfactory, but CO₂ can not be increased to a satisfactory level (12%) or overfire draft of 0.02" W.C. can not be obtained, check for proper sealing between sections, between the hinged burner mounting door and front section, around burner blast tube and around flue collector and collar. If seal is not satisfactory, reseal with furnace putty or silicone with a temperature rating of at least 400° F. (All safety precautions indicated on material package must be followed.)
- G. Once burner and draft have been set up, then smoke, CO₂ and stack temperature should be checked and recorded. If smoke is greater than trace, review the burner instructions and replace the nozzle if necessary. Normal smoke to be expected is zero to a trace.
- H. Make sure that the observation port cover is closed and the screw is tightened.

CLEANING AND FILLING A NEW WATER BOILER

- I. There are a number of commercial preparations available from your distributor for cleaning and for corrosion protection conditioning the internal (waterside) surfaces of boilers. Follow the preparation manufacturer's instructions.

DANGER: Use CAUTION when handling chemicals and draining hot water from a boiler. Scalding water and/or chemicals can cause permanent injury to the skin, eyes and respiratory system.
- II. Filling and venting the water boiler after cleaning
 - A. Refill the system with fresh water.
 - B. Bring water temperature to at least 180° F promptly.
 - C. Circulate water through entire system.
 - D. Vent the system, including the radiation.
 - E. The boiler is now ready to be put into service or on standby.
 - F. If brand name air-control devices are used, venting instructions furnished with the devices should be followed.

WATER CONTENT OF BOILER (GALLONS)			
XL-20	XL-30	XL-40	XL-50
5.5	7.0	8.5	10.0

VOLUME OF WATER IN STANDARD PIPE OR TUBE

Nominal Pipe Size Inches	Standard Steel Pipe			Type L Copper Tube	
	Schedule No.	Inside Diameter Inches	Gallons per Lin. Ft.	Inside Dia. Inches	Gallons per Lin. ft..
3/8	—	—	—	0.430	0.0075
1/2	40	0.622	0.0157	0.545	0.0121
5/8	—	—	—	0.666	0.0181
3/4	40	0.824	0.0277	0.785	0.0251
1	40	1.049	0.0449	1.025	0.0429
1 1/4	40	1.380	0.0779	1.265	0.0653
1 1/2	40	1.610	0.106	1.505	0.0924
2	40	2.067	0.174	1.985	0.161
2 1/2	40	2.469	0.249	2.465	0.248
3	40	3.068	0.384	2.945	0.354

III. Safety check for control system

High limit control test: Set thermostat high enough for boiler water temperature to reach high limit control setting. When this temperature is reached, the high limit switch should open, and the burner should shut off automatically. If the high limit does not operate to shut off the burner, the high limit or the wiring is faulty. Repair or replace immediately.

CARE AND MAINTENANCE

- I. EXTENDED SHUTDOWN, CLEANING OR REMOVAL OF BOILER FROM SERVICE.

DANGER: Use CAUTION when handling chemicals and draining hot water from a boiler. Scalding water and/or chemicals can cause permanent injury to the skin, eyes and respiratory system.

 - A. Shut down burner by disconnecting all electrical power to the burner by turning OFF the BURNER EMERGENCY SWITCH of this boiler. After shutting down burner, while the boiler is still hot (180°F to 200°F), drain water from the bottom of the boiler until it runs clear.
 - B. Provide corrosion protection conditioning to the boiler water in the heating system. There are a number of commercial heating system preparations available from your distributor. Follow the preparation manufacturer's instructions.
 - C. To clean the fireside boiler surfaces, first shut down burner by disconnecting all electrical power to the burner by turning OFF the OIL BURNER EMERGENCY SWITCH of this boiler in order to perform the following work in (1) through (10) below.
 - 1. Remove the flue pipe from the boiler flue collar and clean thoroughly.
 - 2. Inspect the entire vent connector back to the chimney and clean if necessary.
 - 3. Inspect the chimney for soot, debris and other unsafe conditions of the chimney and take the necessary action.
 - 4. Remove the flue collector by first removing the top jacket panel. The flue collector is held in place by two hex 1/4-20 screws. Remove the screws and carefully remove the flue collector. Try not to disturb the flat fiberglass rope under the flue collector.
 - 5. When necessary to clean the combustion chamber you must first CLOSE the suction valve (and return valve if two pipe). Then disconnect the oil lines from the burner. The flexible electric conduit connected from the junction box on the boiler to the burner via a plastic connector must be disconnected from the burner by grasping the plastic half of the connector closest to the flexible conduit and gently pulling it in the direction of the conduit until it is disconnected. Remove the single 3/8-16 hex head screw on the LEFT side of the swinging door. You will need a 9/16" drive socket. Open the door to completely expose the combustion chamber for thorough cleaning and for inspection of target wall, blanket (provided in certain models; see rating plate), main cast iron burner door insulation and burner door fiberglass sealing rope. If combustion chamber parts above are badly deteriorated then replace with original factory parts available at your distributor.

6. Use the flue brush to clean the pinned flueways between the sections.† A wire brush may be used to remove any carbon accumulation that may have developed in the combustion chamber. Vacuum the loose soot and debris from the boiler.
7. Inspect the burner combustion head. Clean if necessary and make sure all the adjustments are correct. (See burner data pages for the burner installed.) Replace oil nozzle with new one and readjust electrodes. To insure proper burner operation **ONLY THE NOZZLES SPECIFIED IN THIS MANUAL OR ON THE BURNER LABEL SHOULD BE USED FOR REPLACEMENT.**
8. Protect all of the fireside surfaces by swabbing with neutral mineral oil.
9. Close main cast iron burner door (door on which burner is mounted). Make sure that the entire seal (fiberglass rope) is making good contact with the boiler casting when replacing 3/8-16 x 1" long hex head bolt and tightening.
10. Check the flue collector seal. This is the flat rope seal on top of the heat exchanger. The rope must be in place adjacent to the long bosses on front and rear sections and adjacent to the short bosses on the intermediate sections. The rope should be directly under the flue collector flanges when the flue collector is replaced. Use the two 1/4-20 x 3/4" washer hex head screws to fasten the flue collector. In order to assure a proper seal be sure that the flue collector is compressing the flat rope and not hanging up on the section bosses. Tighten the two screws.

D. If boiler room is damp, provide ventilation.

II. PROVIDING PROTECTION FOR FREEZING

Anti-freeze is sometimes used in hydronic heating systems to protect against freeze-up in the event of power failure, or safety control shutdown when the building is unoccupied. It should be recognized that unless the building is kept above freezing temperature by some means, the plumbing system is not protected.

PROPYLENE GLYCOL is used in the quick-freeze food industry; it is practically non-toxic. Its use may be permitted when indirect water heaters are used. When anti-freeze must be used, inhibited propylene glycol is recom-

mended. Useful information on the characteristics, mixing proportions, etc. of glycol in heating systems is given in Technical Topics No. 2A, available from the Hydronics Division of GAMA, 35 Russo Place, Berkeley Heights, NJ 07922. Consult glycol manufacturers for sources of propylene glycol.

DO NOT USE ETHYLENE GLYCOL BECAUSE IT IS TOXIC.

III. OIL BURNER

Inspect and clean annually and following any period of improper operation. Recheck and adjust settings as specified for burner model and nozzle size.

Set burner air and draft regulator, using test instruments to obtain recommended CO₂ and draft without smoke.

See the Burner Data page in this manual that corresponds to the burner installed.

IV. GENERAL MAINTENANCE

These operations are recommended to be performed at regular intervals:

- A. **BOILER HEATING SURFACES:** clean off all coatings found. Reseal covers.
- B. **BOILER CONTROLS:** check contacts, settings, correct functioning.
- C. **PIPING:** check piping and accessories for leaks.
- D. **CHIMNEY or STUB VENT and BREECHING:** check for obstructions and leaks.
- E. **COMBUSTION AIR TO BURNER:** check for continued **POSITIVE** supply of air as required. Air needs are greatest in coldest weather. Refer to **AIR SUPPLY**, page 3.
- F. **WATER SYSTEM:** check
 1. System to be full of water and pressure to remain stable (between 12 psi and 25 psi).
 2. Air-control system: noise and air binding in radiation should not occur.
 3. Water lines: slightest leaks should be corrected.
- G. **BOILER ROOM AIR SUPPLY:** air vents should be open and free of obstruction. See page 3.

† A flue brush (2-1/4" dia.) is supplied with boiler. Replacements are available from dealer or hardware stores.

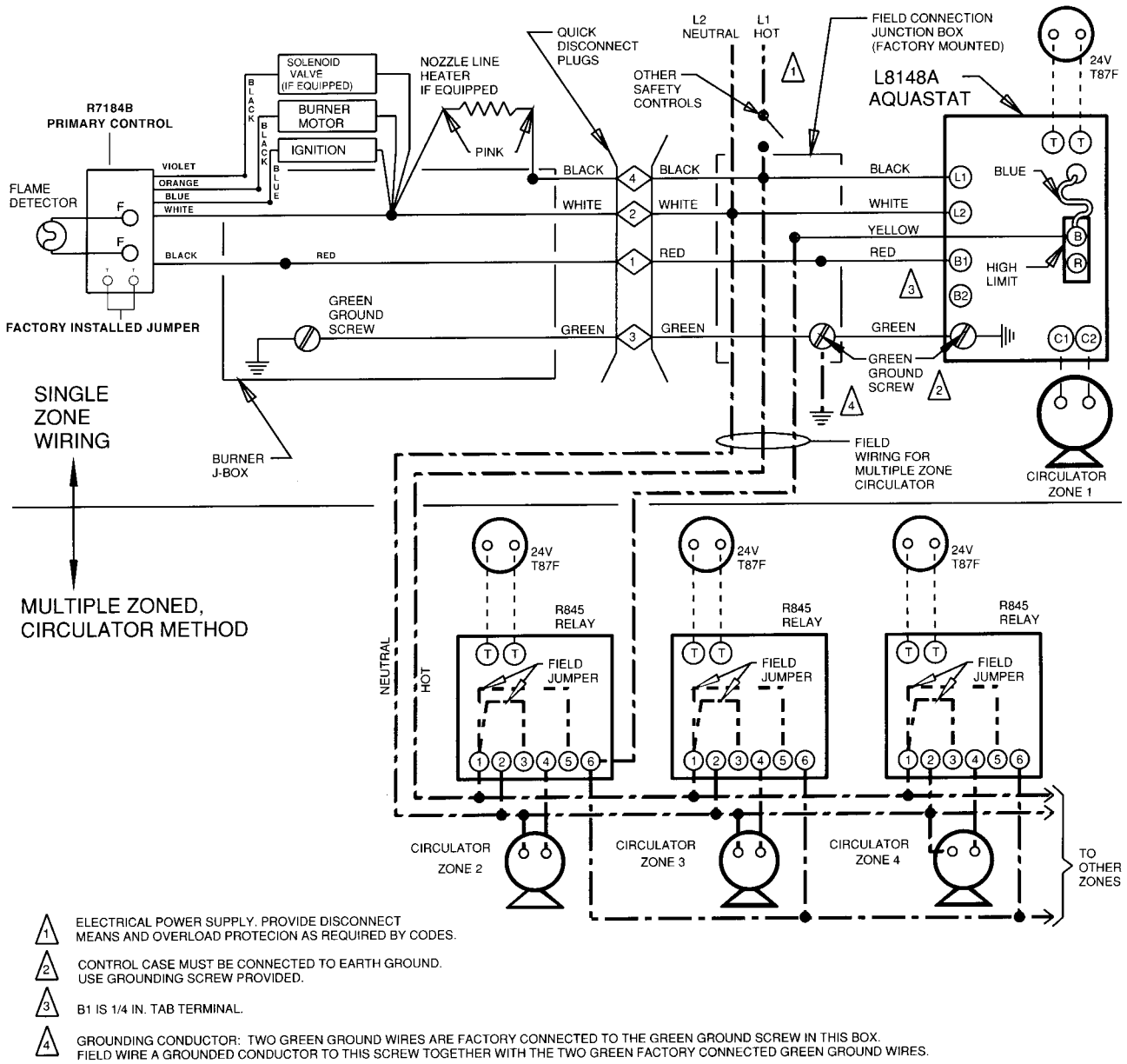

MULTIPLE ZONED, ZONE VALVE METHOD

USING HONEYWELL V8043F OR ERIE 765

LEGEND

FOR SINGLE AND MULTIPLE ZONED DIAGRAMS

FACTORY WIRING	—————
FIELD WIRING	-----
LINE VOLTAGE	-----
24 VOLTS	-----

t ELECTRICAL POWER SUPPLY. OVERLOAD PROTECTION AND DISCONNECT MEANS MUST BE PROVIDED AS REQUIRED BY CODES.

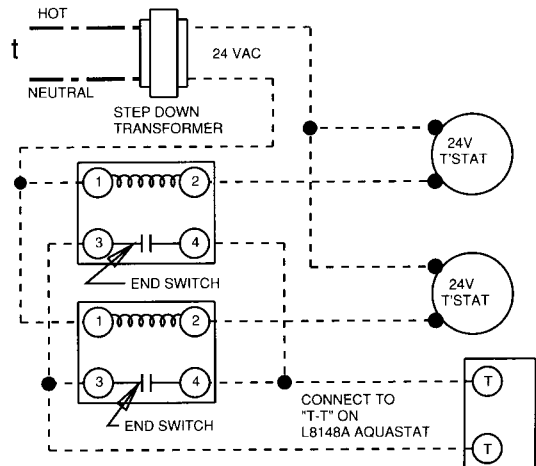

BURNER DATA—CARLIN BURNERS FOR PACKAGED BOILERS ONLY

BOILER MODEL	CARLIN BURNER MODEL (2) (3)	FIRING RATE NO. 2 OIL (GPH)	NOZZLES			OIL PUMP PRESSURE SETTING (PSIG)	"A" APPROXIMATE HEAD SETTING NO.	APPROXIMATE AIR BAND OPENING % (1)	SHUTTER NON-ADJUSTABLE
			SIZE (GPH)	ANGLE AND TYPE	MFR.				
XL-20	99-FRD 71399-00F-XL-20	0.65	0.65	70° A	DELAVAN	100	0	50	Closed
			0.65	70° W	DELAVAN	100	0	50	Closed
XL-30	99-FRD 71399-00F-XL-30	1.00	1.00	70° A	DELAVAN	100	2	80	Closed
		1.15	1.00	70° A	DELAVAN	130	3	90	Closed
XL-40	99-FRD 71399-00F-XL-40	1.35	1.35	60° W	DELAVAN	100	4	50	Closed
		1.55	1.35	60° W	DELAVAN	130	4	65	Closed
XL-50	99-FRD 71399-00F-XL-50	1.80	1.75	60° B	DELAVAN	105	4	20	Open
		2.00	1.75	60° B	DELAVAN	130	5	40	Open

NOTES:

- (1) Single slotted air band for XL-20 and XL-30, double slotted air band for XL-40 and XL-50.
- (2) See "PRECAUTIONS BEFORE STARTING OIL BURNERS" and "START-UP" on page 7 and burner figures on this page.
- (3) All burner models shown are single stage.

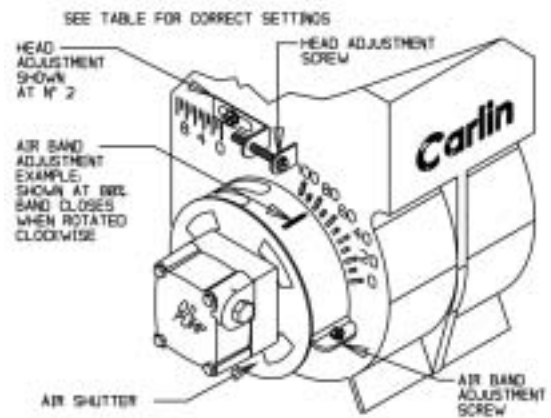
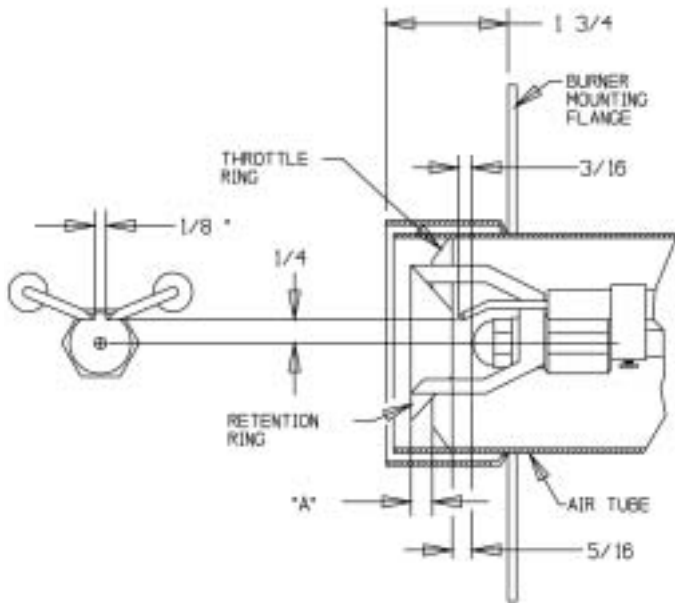

BURNER DATA—BECKETT BURNERS FOR PACKAGED BOILERS ONLY

BOILER MODEL	BECKETT BURNER MODEL (2) (3)	BECKETT BURNER HEAD	FIRING RATE NO. 2 OIL (GPH)	NOZZLES			OIL PUMP PRESSURE SETTING (PSIG)	APPROXIMATE AIR SHUTTER SETTING NO. (1)	APPROXIMATE AIR BAND SETTING NO.	STATIC DISK DIAMETER INCHES
				SIZE (GPH)	ANGLE AND TYPE	MFR.				
XL-20	(4) AFG SF2201	F0	0.65	0.65	80° A	DELAVAN	100	7	Blank/Closed	3 ³ / ₈
XL-30H	AFG SF2204	F3	0.85	0.85	70° W	DELAVAN	100	6	Blank/Closed	2 ³ / ₄
XL-30	AFG SF2202	F3	1.00	1.00	80° W	DELAVAN	100	8	0	2 ³ / ₄
			1.15	1.00	80° W	DELAVAN	130	10	2	2 ³ / ₄
XL-40H	AF SF2205	F6	1.25	1.25	80° W	DELAVAN	100	10	2	None
XL-40	AF SF2203	F6	1.35	1.35	80° W	DELAVAN	100	10	2 ¹ / ₂	None
			1.55	1.35	80° W	DELAVAN	130	10	5	None
XL-50	AF SF2207	F12	1.80	1.75	70° B	DELAVAN	105	10	3	None

NOTES:

- (1) Blank (closed) air band for XL-20, 2 slot band for XL-30, 4 slot band for XL-40 and 8 slot air band for XL-50.
- (2) See "PRECAUTIONS BEFORE STARTING OIL BURNERS" and "START-UP" on page 7 and burner figures on this page.
- (3) All burner models shown are single stage.
- (4) XL-20 is supplied with a low fire baffle (Beckett No. 31760) installed.

