

For Residential, Commercial and Snowmelt Applications

Job Name _____

Contractor _____

Job Location _____

Approval _____

Engineer _____

Contractor's P.O. No. _____

Approval _____

Representative _____

PressAll™ Tool Kits

RadiantPEX-AL Tool

Sizes: 1/2", 5/8", 3/4", 1"

PressAll Tools are designed to create a connection with RadiantPEX-AL tubing and Press fittings.

Specifications

PressAll Tools are available in two sizes:

- 15" tool for 1/2", 5/8", and 3/4" Press connections.
- 19" tool for 1/2", 5/8", 3/4", and 1" Press connection.
- Interchangeable press jaws.
- Contains extra retaining screws and locking washers.
- Easy-to-use integral calibration.
- Contains adjustment and jaw changing tools.
- Protective plastic case holds all components.

Installation/Operation

PressAll tool and accessories should be used in accordance with tool and Press fitting instructions.

1. Cut a clean, square end to the RadiantPEX-AL tubing.
2. Use the Reamer tool to shape and prep the tubing.
3. Make sure the Press sleeve is seated against the insulator base of the connection with the sleeve view ports closest to the plastic base.
4. Slide the RadiantPEX-AL tubing onto the fitting until the tubing visibly fills the view port.
5. Place the Press fitting into one side of the jaws.
6. Close the jaws firmly. Tool will stop automatically when complete.

When changing jaws, be sure to open the tool first to relieve any stress on the jaw head before loosening the screws.

To calibrate the tool:

1. Loosen the Set Screw.
2. Use the Adjustment Tool to tighten or loosen the Adjustment Screw.
3. Tighten the Set Screw.

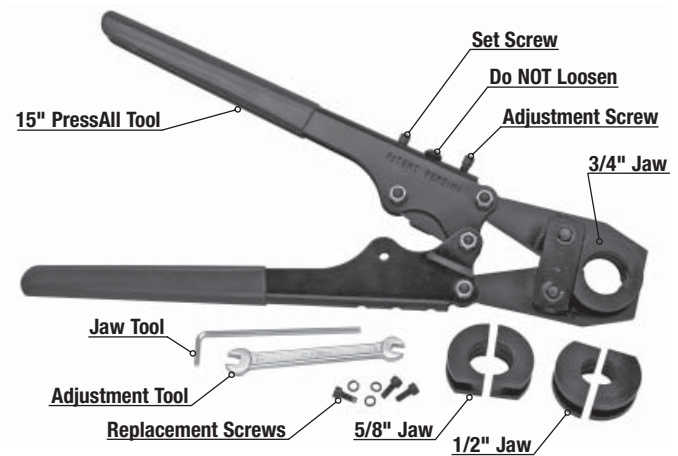

15" PressAll Tool for use with 1/2", 5/8", and 3/4" RadiantPEX-AL tubing.
19" PressAll Tool for use with 1/2", 5/8", 3/4", and 1" RadiantPEX-AL tubing.

PressAll Tools and Accessories

<input checked="" type="checkbox"/>	Description	Part #	Order #
<input type="checkbox"/>	15" PressAll Manual Tool Kit	RLPA-0612-K1	81008140
<input type="checkbox"/>	19" PressAll Manual Tool Kit	RLPA-1624-K2	81008142
<input type="checkbox"/>	15" PressAll Tool, Extra Jaws, 1/2"	RLPAJ15-08	81008143
<input type="checkbox"/>	15" PressAll Tool, Extra Jaws, 5/8"	RLPAJ15-10	81008144
<input type="checkbox"/>	15" PressAll Tool, Extra Jaws, 3/4"	RLPAJ15-12	81008145
<input type="checkbox"/>	15" PressAll Tool Extra Jaws Kit - 1/2", 5/8", 3/4"	RLPAJ15-K1	81008426
<input type="checkbox"/>	19" PressAll Tool, Extra Jaws, 1/2"	RLPAJ19-08	81008024
<input type="checkbox"/>	19" PressAll Tool, Extra Jaws, 5/8"	RLPAJ19-10	81008023
<input type="checkbox"/>	19" PressAll Tool, Extra Jaws, 3/4"	RLPAJ19-12	81008022
<input type="checkbox"/>	19" PressAll Tool, Extra Jaws, 1"	RLPAJ19-16	81008021
<input type="checkbox"/>	19" PressAll Tool Extra Jaws Kit - 1/2", 5/8", 3/4", 1"	RLPAJ19-K1	81008427

Fittings should not be installed when the ambient temperature is below 30°F (0°C).

Jaws for the 15" PressAll tool are not interchangeable with the 19" PressAll tool.

Watts product specifications in U.S. customary units and metric are approximate and are provided for reference only. For precise measurements, please contact Watts Technical Service. Watts reserves the right to change or modify product design, construction, specifications, or materials without prior notice and without incurring any obligation to make such changes and modifications on Watts products previously or subsequently sold.

 **Watts Radiant**
Floor Heating & Snowmelt

A subsidiary of Watts Water Technologies, Inc.

USA: 4500 East Progress Place, Springfield, MO 65803; www.wattsradiant.com

Canada: 5435 North Service Rd., Burlington, ONT. L7L 5H7; www.wattscanada.ca

For Residential, Commercial and Snowmelt Applications

Job Name _____

Contractor _____

Job Location _____

Approval _____

Engineer _____

Contractor's P.O. No. _____

Approval _____

Representative _____

Reamer Tool

RadiantPEX-AL Tool

Sizes: 3/8", 1/2", 5/8", 3/4", 1"

Reamer tools are designed to properly bevel and shape RadiantPEX-AL tubing.

Specifications

Reamers are available in two basic models, 3-sided for all tube sizes (1/2" - 1") and T-handle for larger sizes (3/4" and 1" only).

Reamer Side vs. Tube Size

	Side	Tube Size (i.d.)
Small	14	3/8"
	16	1/2"
	18	Not Used
Large	20	5/8"
	25	3/4"
	32	1"

Installation

RadiantPEX-AL must be installed in accordance with all Watts Radiant installation procedures, including information provided in the RadiantPEX-AL installation manual and guidelines.

1. Cut a clean, square end to the tube. If a square cut is not achieved, a uniform bevel will not be created.
2. Insert Reamer into tubing, twisting the tool as needed. Make sure tubing sits against base of Reamer.
3. Press tubing against Reamer base and turn. A ribbon of PEX will be removed from inner tubing, creating a bevel.
4. Remove Reamer.

Fittings should not be installed when the ambient temperature is below 30°F (0°C).

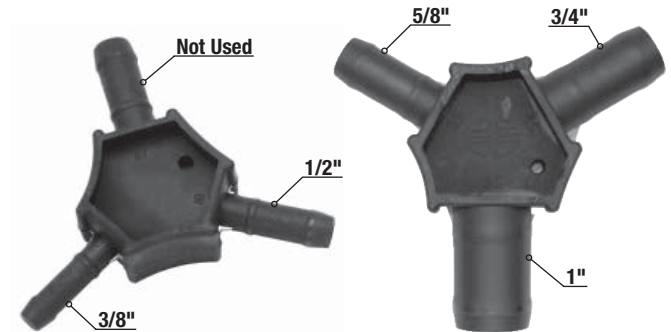

3/8"-1/2" 3-Sided Reamer

5/8"-1" 3-Sided Reamer



3/4" and 1" T-Handle Reamers

Reamer Options

<input checked="" type="checkbox"/>	Description	Part #	Order #
<input type="checkbox"/>	3-Sided Reamer, 3/8"-1/2"	RLR-0608	81008428
<input type="checkbox"/>	3-Sided Reamer, 5/8"-1"	RLR-1016	81008429
<input type="checkbox"/>	T-Handle Reamer, 3/4"	RLTR-12	81008430
<input type="checkbox"/>	T-Handle Reamer, 1"	RLTR-16	81008431

Watts product specifications in U.S. customary units and metric are approximate and are provided for reference only. For precise measurements, please contact Watts Technical Service. Watts reserves the right to change or modify product design, construction, specifications, or materials without prior notice and without incurring any obligation to make such changes and modifications on Watts products previously or subsequently sold.

 **Watts Radiant**
Floor Heating & Snowmelting

A subsidiary of Watts Water Technologies, Inc.

USA: 4500 East Progress Place, Springfield, MO 65803; www.wattsradiant.com

Canada: 5435 North Service Rd., Burlington, ONT. L7L 5H7; www.wattscanada.ca